



WE CARE. WE DELIVER.

Environmental Management System

Rix's Creek Mine

Rix's Creek North and Rix's Creek South

**BUSHFIRE MANAGEMENT PLAN**

Doc No: Bushfire Management Plan

Doc Owner: Environment Manager – Rix's Creek Pty Ltd

Approval: Operations Manager – The Bloomfield Group

Signed: B Clements

Date: 1/04/2026

Revision	Issue Date	Description	Originator	Reviewed	Approved
Draft	30/10/2019		H. Lumsden	Chris Quinn	Chris Knight
1.0	13/1/2020	RFS feedback received	C. Knight	Chris Quinn	Chris Knight
1.1	24/1/2020	RFS feedback incorporated into plan	C. Knight	Chris Quinn	Chris Knight
1.2	5/06/2024	Schedule inspections of firebreaks.	Chris Quinn	Chris Quinn	Brendon Clements
1.3	1/04/2026	Updated firebreak, Land ownership and emergency plans	Chris Quinn	Julius Harris-Payne	Brendon Clements

Document Title: **Bushfire Management Plan – Rix's Creek Mine**

Prepared By: Chris Quinn

Print Date:

1-Apr-26

Document Owner: **Chris Knight**

Version No:

1.3

Reviewed By: Julius Harris-Payne

Issue Date:

1/04/2026

Approved By: Brendon Clements

Review Frequency:

**As Required**

Page No:

1 of 35

Bushfire Management Plan  
Rix's Creek North & Rix's Creek South

---

Document Title:	<b>Bushfire Management Plan – Rix's Creek Mine</b>		Document Owner:	<b>Chris Knight</b>	
Prepared By:	Chris Quinn	Print Date:	1-Apr-26	Version No:	1.3
Reviewed By:	Julius Harris-Payne	Review Frequency:	<b>As Required</b>	Issue Date:	1/04/2026
Approved By:	Brendon Clements			Page No:	2 of 35

## Table of Contents

TABLE OF CONTENTS.....	3
1. PURPOSE.....	5
2. SCOPE.....	5
3. BACKGROUND.....	6
4. CONSENT CONDITIONS.....	8
5. BUSHFIRE HAZARD.....	10
5.1 CLIMATE AND BUSHFIRE SEASON .....	11
5.2 TOPOGRAPHY .....	11
5.3 BUSHFIRE RISK (IGNITION SOURCES) .....	11
5.3.1 FLAMMABLE LIQUIDS AND MATERIALS .....	11
6. MINE SITE ASSETS .....	14
6.1 ECONOMIC ASSETS.....	14
6.2 ENVIRONMENTAL ASSETS .....	14
6.3 CULTURAL ASSETS .....	14
6.4 HUMAN SETTLEMENT .....	15
7. RIX'S CREEK BUSHFIRE PROTECTION MEASURES AND PREPAREDNESS.....	15
7.1 EQUIPMENT.....	15
7.2 VEGETATION AND FIRE BREAK MANAGEMENT .....	16
7.3 FIRE BANS .....	18
7.4 BIODIVERSITY AREAS.....	18
8. HOT WORKS MANAGEMENT .....	18
8.1 HOT WORK PERMIT .....	21
8.2 CIRCUMSTANCES WHEN 'HOT WORKS' ARE LIMITED OR PROHIBITED .....	21
8.2.1 HOT WORKS DURING FIRE BAN.....	21
8.2.2 HOT WORK IN HAZARDOUS AREAS.....	22
8.3 HOT WORKS SAFETY MEASURES.....	23
9. BUSHFIRE MANAGEMENT AND EMERGENCY RESPONSE.....	23
9.1 BUSHFIRE EMERGENCY RESPONSE PROCEDURE .....	23
9.1.1 RFS AND EMERGENCY SERVICES ACCESS POINTS .....	24
9.2 EMERGENCY RESPONSE PERSONEL.....	24
9.3 EMERGENCY CONTACTS.....	25
9.4 EMERGENCY EVACUATION.....	25

Document Title:	<b>Bushfire Management Plan – Rix's Creek Mine</b>		Document Owner:	<b>Chris Knight</b>	
Prepared By:	Chris Quinn	Print Date:	1-Apr-26	Version No:	1.3
Reviewed By:	Julius Harris-Payne	Review Frequency:	<b>As Required</b>	Issue Date:	1/04/2026
Approved By:	Brendon Clements			Page No:	3 of 35

Bushfire Management Plan  
Rix's Creek North & Rix's Creek South

---

9.5	SUPPORTING THE RFS .....	28
10.	REPORTING .....	28
11.	DOCUMENT REVIEW AND IMPROVEMENT .....	28
12.	ROLES AND RESPONSIBILITIES .....	28
13.	DEFINITIONS .....	30
14.	REFERENCES.....	31
15.	APPENDICIES.....	32
15.1	PLANNING FOR BUSHFIRE PROTECTION (RFS, 2006).....	32
15.2	GUIDELINES FOR THE PREPARATION OF EMERGENCY/EVACUATION PLAN (RFS).....	33
15.3	AUSTRALIAN STANDARD AS 3745 PLANNING FOR EMERGENCIES IN FACILITIES .....	34
15.4	CONSULTATION WITH NSW RURAL FIRE SERVICE .....	35

Document Title:	<b>Bushfire Management Plan – Rix's Creek Mine</b>		Document Owner:	<b>Chris Knight</b>	
Prepared By:	Chris Quinn	Print Date:	1-Apr-26	Version No:	1.3
Reviewed By:	Julius Harris-Payne	Review Frequency:	<b>As Required</b>	Issue Date:	1/04/2026
Approved By:	Brendon Clements			Page No:	4 of 35

## 1. PURPOSE

The Bloomfield Group has a duty as a land owner under Section 63(2) of the Rural Fires Act 1997 (RF Act) to prevent the occurrence of bushfires on, and to minimise the danger of the spread of bushfires on Rix's Creek land.

The purpose of this Bushfire Management Plan (BMP) is to;

- Mitigate the risk of a bushfire occurrence;
- Minimise the potential for spread of bushfires in, from or into RCM
- Mitigate the risk to personnel on Rix's Creek Mine from bushfire events;
- Ensure that Bloomfield assets are to all possible extent protected from damage from fires Starting either in or outside the Rix's Creek Mine site;
- Take steps to manage ignition sources on site;
- Take steps to mitigate the risk of bushfire outbreak migrating to adjacent properties.
- Work co-operatively with neighbours, lessees and rural fire brigades in managing bushfires.
- To mitigate the risk of a bushfire outbreak impacting on Aboriginal and European heritage sites, and threatened or endangered flora and fauna located within the Mine site from fire damage;
- To outline the bushfire emergency response; and
- To document preventative strategies to reduce the risk of occurrence of unplanned bushfires

## 2. SCOPE

This Bushfire Management Plan applies to land within the Rix's Creek Mine (hereafter referred to as the Mine or RCM) and associated properties under the control of Bloomfield Collieries Pty Limited (hereafter referred to as Bloomfield). The location of the RCM mining lease boundary is attached in **Figure 1**.

This BMP provides for asset protection in accordance with the relevant requirements in the Planning for Bushfire Protection (RFS, 2006) guideline (Appendix 15.1) and includes an Emergency Evacuation Plan drawn in accordance with the Guidelines for the Preparation of Emergency/Evacuation Plan (RFS) (Appendix 15.2) and Australian Standard AS 3745 Planning for Emergencies in Facilities (Appendix 15.3).

This BMP is implemented in consultation with the local authority of the New South Wales Rural Fire Service (Appendix 15.4).

Document Title:	<b>Bushfire Management Plan – Rix's Creek Mine</b>		Document Owner:	<b>Chris Knight</b>
Prepared By:	Chris Quinn	Print Date:	Version No:	1.3
Reviewed By:	Julius Harris-Payne		Issue Date:	1/04/2026
Approved By:	Brendon Clements	Review Frequency:	Page No:	5 of 35

---

### 3. BACKGROUND

---

RCM is owned and operated by The Bloomfield Group (Bloomfield). It is an open cut coal mine situated within the Singleton local government area, approximately 5 km north-west of Singleton in the Hunter Valley Coalfields of NSW. The Mine comprises the original Rix's Creek Mine, now known as Rix's Creek South (RCS) and the former Vale-Integra Open Cut Mine now known as Rix's Creek North (RCN). RCS has been in continuous operation by Bloomfield since project commencement in 1990 and RCN was purchased by Bloomfield in 2015. RCM covers a combined area of approximately 2500 hectares. **Figure 1** below identifies Rix's Creek land ownership relevant to this BMP.

Rix's Creek Mine is contained within the NSW RFS District of **Hunter Valley District** and is located within the Fire Weather Area of **Greater Hunter**. The bushfire Management Committee for this area is the **Hunter Valley Bush Fire Management Committee**.

Document Title:	<b>Bushfire Management Plan – Rix's Creek Mine</b>		Document Owner:	<b>Chris Knight</b>	
Prepared By:	Chris Quinn	Print Date:	1-Apr-26	Version No:	1.3
Reviewed By:	Julius Harris-Payne	Review Frequency:	<b>As Required</b>	Issue Date:	1/04/2026
Approved By:	Brendon Clements			Page No:	6 of 35

**Bushfire Management Plan  
Rix's Creek North & Rix's Creek South**

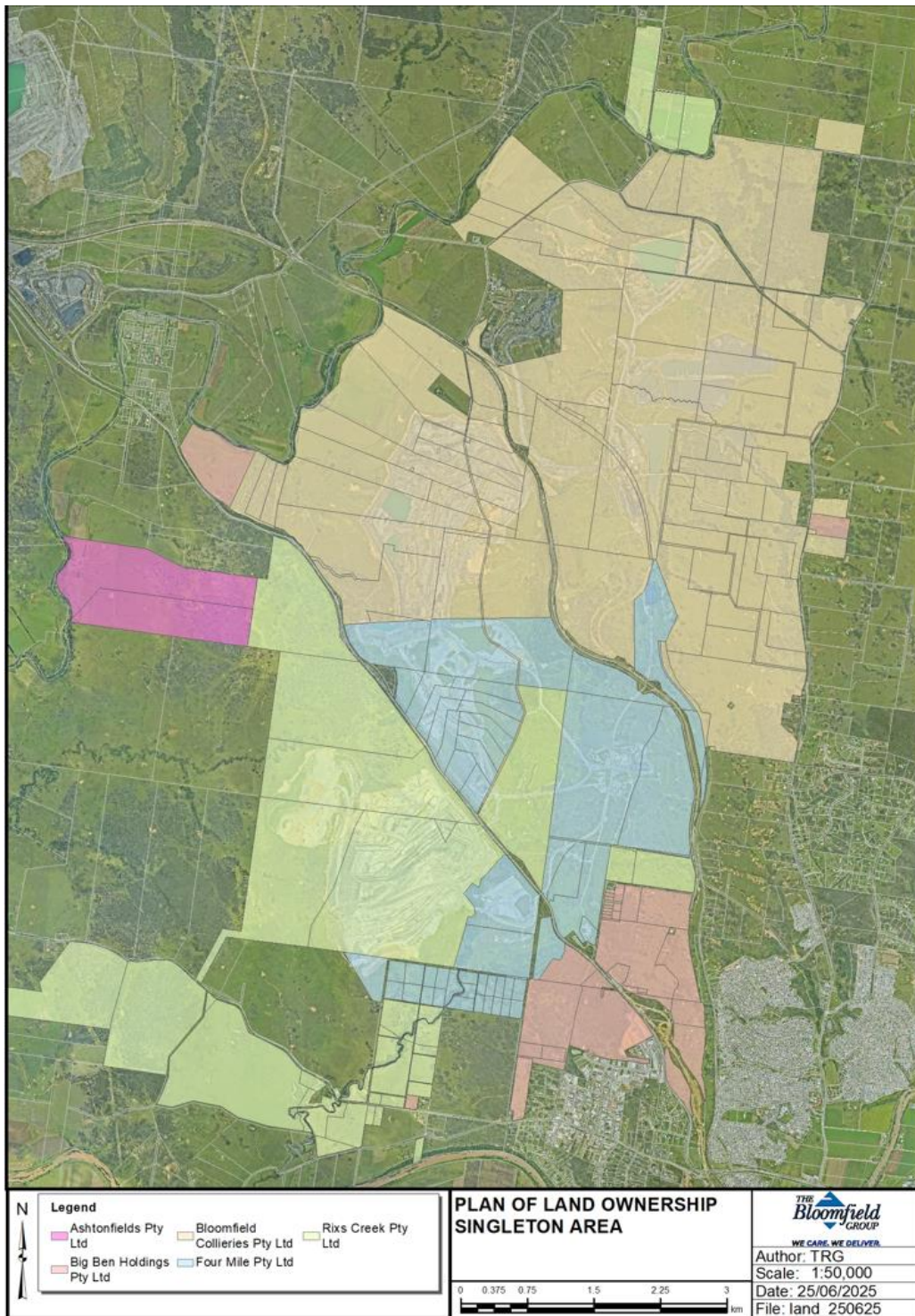

Figure 1 Rix's Creek Land Ownership

Document Title:	<b>Bushfire Management Plan – Rix's Creek Mine</b>	Document Owner:	<b>Chris Knight</b>
Prepared By:	Chris Quinn	Print Date:	1-Apr-26
Reviewed By:	Julius Harris-Payne	Version No:	1.3
Approved By:	Brendon Clements	Issue Date:	1/04/2026
	Review Frequency:		Page No: 7 of 35

## 4. CONSENT CONDITIONS

The operations at Rix's Creek South are subject to the conditions contained in the Development Consent (SSD 6300) dated 12/10/2019. SSD 6300 is granted under the Environmental Planning & Assessment Act 1979 (EP&A Act). All bushfire management related conditions of SSD6300 are requirements related to this Plan. These are summarised in Table 1

*Table 1 Relevant SSD6300 Conditions to this Bushfire Management Plan*

Rix' s Creek South (SSD 6300)	Condition	Relevant Plan Section
B66	<b>BUSHFIRE MANAGEMENT</b> The Applicant must:	
B66(a)	Ensure that the development:	
B66(a)(i)	provides for asset protection in accordance with the relevant requirements in the <i>Planning for Bushfire Protection</i> (RFS, 2006) guideline; and	6 7.2
B66(a)(ii)	ensure that there is suitable equipment to respond to any fires on the site; and	7.1
B66(b)	assist the RFS and emergency services to the extent practicable if there is a fire in the vicinity of the site.	9.1 9.1.1
B67	Prior to commencing mining operations under this consent, the Applicant must prepare a Bushfire Management Plan for the development in consultation with RFS. This plan must include a:	
B67(a)	contact person and 24 hour contact phone number;	9.3
B67(b)	schedule and description of proposed bushfire mitigation works, including:	7.2
B67(b)(i)	location of managed and unmanaged vegetation within the site;	

Document Title:	<b>Bushfire Management Plan – Rix's Creek Mine</b>		Document Owner:	<b>Chris Knight</b>	
Prepared By:	Chris Quinn	Print Date:	1-Apr-26	Version No:	1.3
Reviewed By:	Julius Harris-Payne	Review Frequency:	<b>As Required</b>	Issue Date:	1/04/2026
Approved By:	Brendon Clements			Page No:	8 of 35

Bushfire Management Plan  
Rix's Creek North & Rix's Creek South

B67(b)(ii)	location of water supply; and	
B67(b)(iii)	internal access roads;	
B67(c)	plan identifying the location and storage of bulk flammable liquids and materials;	5.3.1
B67(d)	'hot works' management plan, including:	8
B67(d)(i)	circumstances when 'hot works' are limited or prohibited; and	8.2
B67(d)(ii)	safety measures to be implemented when 'hot works' and being conducted; and	8.3
B67(e)	Emergency / evacuation plan in accordance with the <i>Guidelines for the Preparation of Emergency/Evacuation Plans (RFS)</i> and Australian Standard <i>AS 3745 Planning for Emergencies in Facilities</i> .	9.4
B68	The Applicant must implement the Bushfire Management Plan in consultation with RFS.	

Table 2 below outlines the relevant conditions from PA 08\_0102 that are applicable to this BMP.

*Table 2 Relevant PA 08\_0102 Conditions to this Bushfire Management Plan*

Rix' s Creek North (PA 08_0102)	Condition	Relevant Plan Section
49	<b>BUSHFIRE MANAGEMENT</b> The Proponent must:	
49(a)	Ensure that the project is suitably equipped to respond to fires on site; and	7.1
49(b)	Assist the Rural Fire Service and emergency services as much as possible if there is a fire in the vicinity of the site.	9.1 9.1.1

Document Title:	<b>Bushfire Management Plan – Rix's Creek Mine</b>		Document Owner:	<b>Chris Knight</b>	
Prepared By:	Chris Quinn	Print Date:	1-Apr-26	Version No:	1.3
Reviewed By:	Julius Harris-Payne	Review Frequency:	<b>As Required</b>	Issue Date:	1/04/2026
Approved By:	Brendon Clements			Page No:	9 of 35

**Bushfire Management Plan  
Rix's Creek North & Rix's Creek South**

**Rix's Creek South Statement of Commitments**

Bloomfield Collieries outlined a number of commitments as part of the Environmental Impact Statements (EIS) for SSD6300 dated 5 March 2019. The commitments relevant to this Plan and the section of the Plan where these items are addressed are outlined in Table 3.

*Table 3: Rix's Creek South Statement of Commitments.*

No.	Factor	Management and Mitigation Measures	Relevant Section of BMP where addressed	Comments
53	Bushfire	A monitoring program will be conducted to monitor fuel load during the fire season.	7	
54	Bushfire	Fuel reduction activities will be undertaken to limit the speed and spread of potential unscheduled fires. This will include thinning or removal of undergrowth.	7.2	
55	Bushfire	Hazard reduction burning will not be undertaken during periods of declared total fire bans.	7.3	
56	Bushfire	Fire trail and access roads to, from and within the mine-owned land will continue to be maintained to a level suitable to provide access for Rural Fire Service tankers.	7.2	
57	Bushfire	The responsibilities for fire management will continue to be those outlined in the internal Fire and Explosion Principal Mining Hazard Management Plan.		
58	Bushfire	In the instance of a bushfire event, the existing Emergency Response Procedures for the Mine will be implemented. Bushfire commitments will be included in a Bushfire Management Plan.	9F	

**5. BUSHFIRE HAZARD**

Document Title:	<b>Bushfire Management Plan – Rix's Creek Mine</b>	Document Owner:	<b>Chris Knight</b>
Prepared By:	Chris Quinn	Print Date:	1-Apr-26
Reviewed By:	Julius Harris-Payne	Version No:	1.3
Approved By:	Brendon Clements	Issue Date:	1/04/2026
	Review Frequency:	<b>As Required</b>	Page No:
			10 of 35

## 5.1 CLIMATE AND BUSHFIRE SEASON

RCM is located within the Hunter Valley District of the NSW Rural Fire Service. The fire season for this area generally begins 1 September and concludes 31 March, however this may vary from time to time depending on meteorological circumstances such as dry or drought conditions, winds and rainfall patterns.

RCM monitors the NSW Rural Fire Service website for season opening and closing dates and monitors the NSW Rural Fire Service website for updates during the nominated fire season.

Wind directions are typically consistent from year to year in line with the following;

- Summer dominated by winds emanating from the south east;
- Autumn dominated by east / south-easterly winds during March and April, with a major shift in wind direction to a dominance by west / north-westerlies occurring in May;
- Winter strongly dominated by west to north-westerlies; and
- Spring dominated by a relatively even combination of east / south-easterlies and west / north-westerlies.

Prevailing weather conditions associated with the bush fire season in the RCM Bushfire Control Area are high temperatures combined with strong, dry westerly winds causing low humidity. There are also frequently dry lightning storms occurring during the bush fire season.

## 5.2 TOPOGRAPHY

Topography has a significant effect on bushfire behaviour. For every increase in slope gradient, there is a similar increase in fire intensity and rate of fire spread. Fires burning uphill pose the most significant hazard.

The topography of the vegetated areas of RCM are generally level. Rehabilitation across RCM is limited to 14 -18 degree slopes, with the general standard across RCM being 14 degrees to best achieve effective grazing final land use. The fire hazard within and surrounding RCM is generally low due to the undulating nature of the topography, the general absence of long uphill slopes and the disturbed nature of the site.

## 5.3 BUSHFIRE RISK (IGNITION SOURCES)

Bushfire ignition sources include natural occurrences such as lightning strikes while other occurrences include sparks from power lines and human ignition. High intensity fires, once ignited, occur as a result of low humidity, high temperatures and strong winds during early to mid-summer.

### 5.3.1 FLAMMABLE LIQUIDS AND MATERIALS

Location of bulk flammable liquids and materials are identified in figures 2 and 3 below.

Document Title:	<b>Bushfire Management Plan – Rix's Creek Mine</b>		Document Owner:	<b>Chris Knight</b>
Prepared By:	Chris Quinn	Print Date:	1-Apr-26	Version No: 1.3
Reviewed By:	Julius Harris-Payne	Review Frequency:	<b>As Required</b>	Issue Date: 1/04/2026
Approved By:	Brendon Clements			Page No: 11 of 35

Bushfire Management Plan  
Rix's Creek North & Rix's Creek South

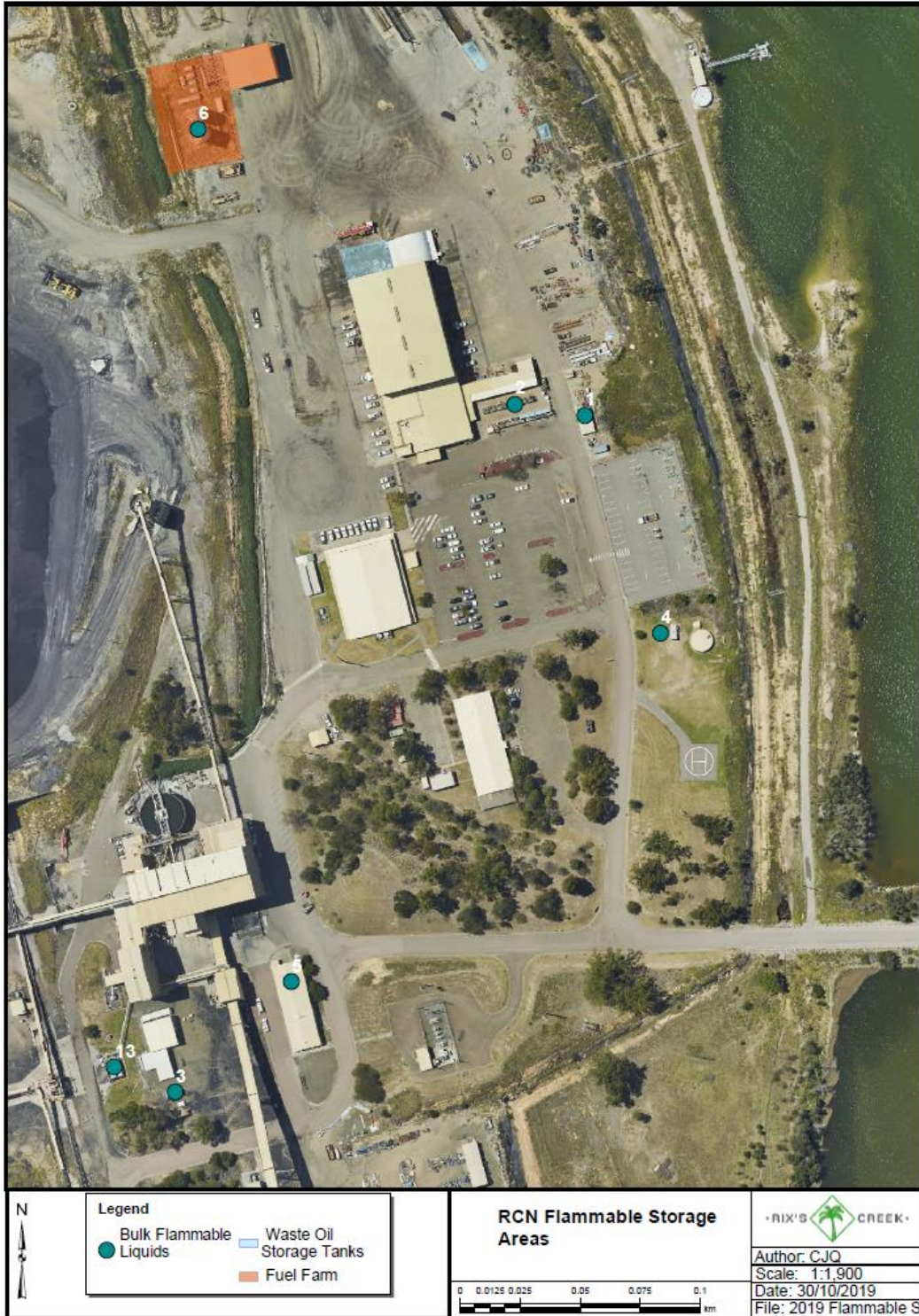

Figure 2 RCN Flammable Storage Areas

Document Title:	<b>Bushfire Management Plan – Rix's Creek Mine</b>		Document Owner:	<b>Chris Knight</b>	
Prepared By:	Chris Quinn	Print Date:	1-Apr-26	Version No:	1.3
Reviewed By:	Julius Harris-Payne	Review Frequency:	<b>As Required</b>	Issue Date:	1/04/2026
Approved By:	Brendon Clements			Page No:	12 of 35

Bushfire Management Plan  
Rix's Creek North & Rix's Creek South



Figure 3 RCS Bulk Flammable Storage Areas

Document Title:	<b>Bushfire Management Plan – Rix's Creek Mine</b>		Document Owner:	<b>Chris Knight</b>
Prepared By:	Chris Quinn	Print Date:	1-Apr-26	Version No: 1.3
Reviewed By:	Julius Harris-Payne	Review Frequency:	<b>As Required</b>	Issue Date: 1/04/2026
Approved By:	Brendon Clements			Page No: 13 of 35

## 6. Mine Site Assets

In relation to bushfire management, assets are defined as anything valued by the community which includes but is not limited to houses, crops, forests, livestock, heritage buildings and places, infrastructure, the environment, commercial and industrial buildings and equipment, which may be at risk from bushfire. Under this plan, where possible, assets will be protected from the effects of bushfire by the establishment of Asset Protection Zones (APZs) around assets at risk and by the establishment of appropriate firebreaks and vegetation maintenance.

### 6.1 ECONOMIC ASSETS

- Mine surface infrastructure, including fences and pipelines
- Mobile Plant and Equipment
- Offsite buildings and infrastructure
- Rail line and rail loading facilities,
- Coal Handling and Preparation Plants
- Coal Stockpiles and infrastructure
- Coal stockpiles located at the CHPP and adjacent to the Deep Pit area;
- Power lines and on-site Power sub-station; and
- Administration, workshop buildings and equipment laydown areas.

### 6.2 ENVIRONMENTAL ASSETS

Biodiversity Offset Areas and non-disturbance areas inclusive of this RCM contain native woodland vegetation and native pastures that provide habitat for a number of native threatened fauna species. The following species have been confirmed to exist within Rix's creek Biodiversity Offset areas'

- Grey-crowned Babbler, *Pomatostomus temporalis*;
- Eastern Bentwing-bat, *Miniopterus schreibersii oceanensis*;
- Eastern Freetail-bat, *Mormopterus norfolcensis*; and
- Brush-tailed Phascogale, *Phascogale tapoatafa*.
- The Grey-headed Flying-fox, *Pteropus poliocephalus*, is also expected to be present.

### 6.3 CULTURAL ASSETS

- European Heritage Sites;
  - James Glennie grave site
  - Coke Ovens
  - Trig Station

Document Title:	<b>Bushfire Management Plan – Rix's Creek Mine</b>		Document Owner:	<b>Chris Knight</b>	
Prepared By:	Chris Quinn	Print Date:	1-Apr-26	Version No:	1.3
Reviewed By:	Julius Harris-Payne	Review Frequency:	<b>As Required</b>	Issue Date:	1/04/2026
Approved By:	Brendon Clements			Page No:	14 of 35

- Aboriginal Archaeological Sites

There are a number of Aboriginal sites located within the area covered by this BMP. Due to the nature of these sites the majority are not likely to be adversely affected by bushfire.

Known Aboriginal sites are identified within the Rix's Creek South Aboriginal Cultural Heritage Management Plan.

## 6.4 HUMAN SETTLEMENT

This BMP covers numerous private and leased properties. RCM will endeavour to prevent a bushfire from entering neighbouring properties.

# 7. RIX'S CREEK BUSHFIRE PROTECTION MEASURES AND PREPAREDNESS

All personnel conducting works on site complete an appropriate level of fire awareness and general safety training via Bloomfield Site Induction Process.

In the event of a bushfire, site specific inductions advise personnel to first ensure the immediate safety of themselves and others, followed by contacting their supervisor and enacting the appropriate emergency response, detailed further in Section 8.1 of this plan.

In the event of a bushfire outbreak, the site emergency response procedures will be activated.

## 7.1 EQUIPMENT

All equipment used on site will undergo the RCM approved Introduction to Site process. In addition to this, approved 103 pre-start equipment inspections are conducted prior to use of all plant and machinery. Scheduled maintenance services are conducted on all mine site equipment to identify and repair identified faults.

Fire Fighting Resources incorporate the following equipment and facilities:

- A supply of Fire Hoses & Fittings (compatible with external emergency services firefighting equipment) and contained in the Fire Depots in strategic positions around the operation;
- Fire Extinguishers;
- Appropriate tools in the Emergency Response Cabinets
- Large water carts and smaller water trucks

Document Title:	<b>Bushfire Management Plan – Rix's Creek Mine</b>		Document Owner:	<b>Chris Knight</b>	
Prepared By:	Chris Quinn	Print Date:	1-Apr-26	Version No:	1.3
Reviewed By:	Julius Harris-Payne	Review Frequency:	<b>As Required</b>	Issue Date:	1/04/2026
Approved By:	Brendon Clements			Page No:	15 of 35

---

## 7.2 VEGETATION AND FIRE BREAK MANAGEMENT

---

The disturbed areas of RCM provide fire breaks and fuel reduction zones that assist in the prevention of bushfire. Additional firebreaks are provided along site boundaries and major roads. The firebreak plan for the site is provided in Figure 4.

Firebreaks, grassland, lawn, garden and road verges around the site and office buildings are to be kept in a condition to provide adequate setbacks and minimise fuel levels. A number of mechanical methods may be used to achieve a reduction in fuel levels. Such methods include mowing, slashing, herbicide spraying, ploughing, and manual removal.

Where possible Asset Protection Zones (APZ) are established and maintained around key infrastructure on site. This includes administration buildings, remote assets, rail loop infrastructure (including locomotive provisioning facility), overhead power lines, open cut and underground facilities and the coal handling and preparation plant (CHPP). Asset protection zones are buffer zones of minimised fuel loads between a bush fire hazard (i.e. bushland) and infrastructure.

The RCS West Pit open cut mining operation and the New England Highway create a very effective fire break which will assist firefighting authorities in controlling a major fire running north from the Maison Dieu Industrial Estate bushland. Thomas Lane also acts as an effective fire break, limiting the spread of a possible fire onto the Northern Biodiversity Offset area from a major fire running south from Mt Olive.

Administration, workshop buildings and equipment laydown areas are located within the central portion of mining operations approximately 100 metres from bushland vegetation. No bushfire mitigations works are generally required for these assets.

Fuel loads will be assessed and periodically inspected in winter to ensure that resources are assigned to control fuel loads by slashing firebreaks. Site personnel or contractors will complete further visual inspections in spring, to ensure that fire breaks remain in place before summer periods.

Document Title:	<b>Bushfire Management Plan – Rix's Creek Mine</b>		Document Owner:	<b>Chris Knight</b>
Prepared By:	Chris Quinn	Print Date:	1-Apr-26	Version No: 1.3
Reviewed By:	Julius Harris-Payne	Review Frequency:	<b>As Required</b>	Issue Date: 1/04/2026
Approved By:	Brendon Clements			Page No: 16 of 35

Bushfire Management Plan  
Rix's Creek North & Rix's Creek South

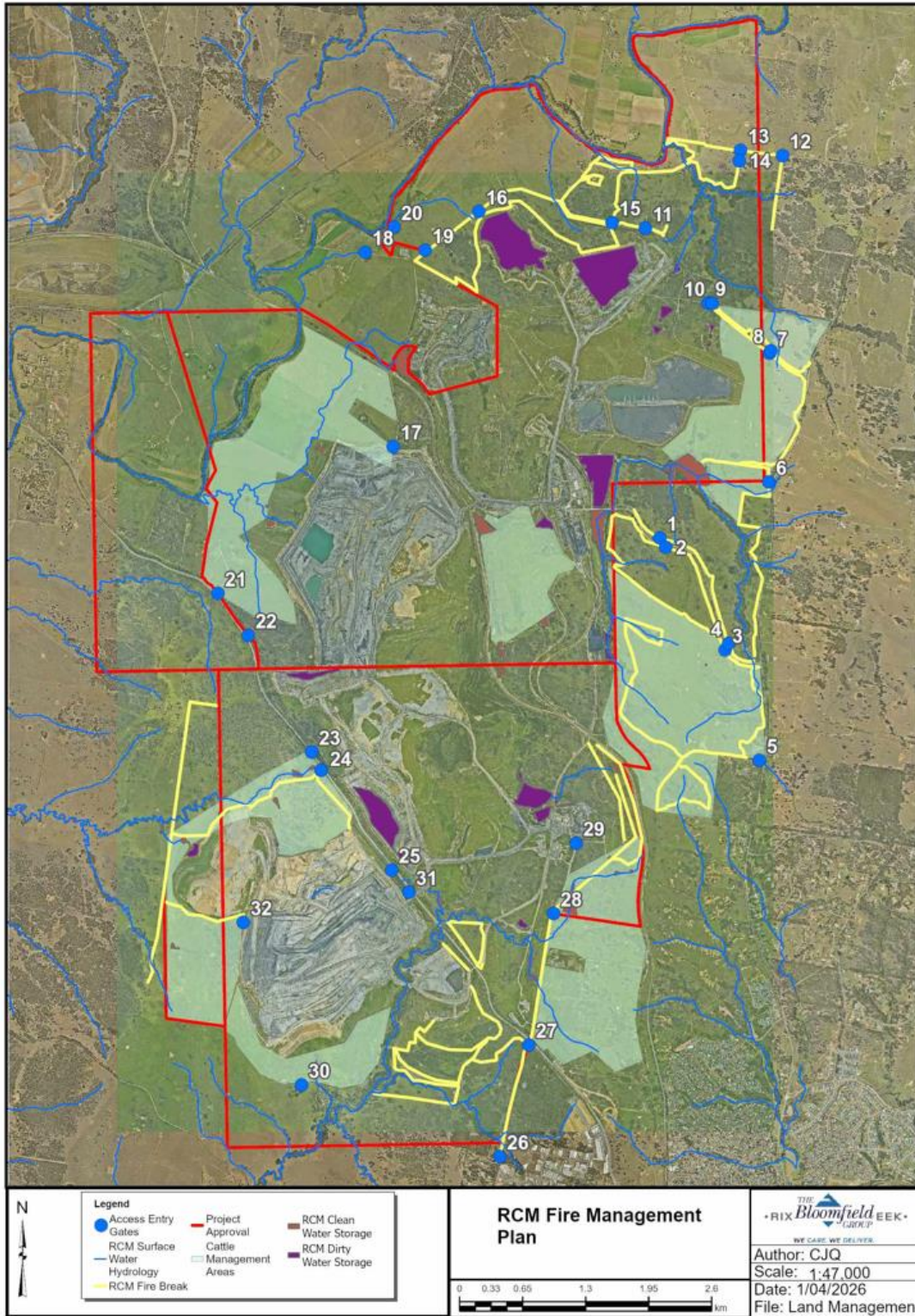

Figure 4 Rix's Creek Fire Management Plan

Document Title:	<b>Bushfire Management Plan – Rix's Creek Mine</b>		Document Owner:	<b>Chris Knight</b>	
Prepared By:	Chris Quinn	Print Date:	1-Apr-26	Version No:	1.3
Reviewed By:	Julius Harris-Payne	Review Frequency:	<b>As Required</b>	Issue Date:	1/04/2026
Approved By:	Brendon Clements			Page No:	17 of 35

### 7.3 FIRE BANS

Fire bans, as determined by the Singleton Rural Fire Service, will be communicated to and adhered to by all staff and enforced by the Mine Manager, at Rix's Creek Mine.

During times of Fire Ban ignition sources such as welding and cutting operations (hot works) will be restricted in accordance with the **Hot Works Management (Section 8)**

### 7.4 BIODIVERSITY AREAS

A number of Biodiversity Offset Areas (BOAs) surround Rix's Creek Mine. Rix's Creek Mine is required to manage bushfire hazard in BOA's. Activities that will be undertaken to limit the risk of fire occurring in, or spreading into the BOAs include;

- Annual slashing of boundary fences to create fire breaks
- Maintenance of access tracks via slashing for bushfire fighting purposes and fire breaks

## 8. Hot Works Management

All work activities conducted at RCM are assessed for risks during the job planning stage in accordance with Company Risk Management Systems. Hazards are identified, risks are assessed and controls are implemented.

In addition to the standard risk management process, the following will apply to all Hot Work to be conducted at RCM:

- Hot Work may be carried out in designated Hot Work Areas after an appropriate risk assessment has been carried out if there are no hazards identified that would require a Hot Work Permit to be completed. RCN Hot Work Areas are identified below in **Figure 5** and RCS Hot Work Areas are identified in **Figure 6**.
- In all other areas, a Hot Work Pre-Start Risk Assessment Form (Section 1 and Section 2 of Hot Work Permit) must be completed for any Hot Work. The form assists in the identification of hazards. All persons conducting Hot Work on a particular task must sign the form before commencing work. The form may indicate to the user that a Hot Work Permit (Section 3) must be completed (Note: A Hot Work Permit includes all 3 sections)

An audit of persons undertaking Hot Work Task/s may be conducted periodically by the area Supervisors or Managers to ensure compliance with the Hot Work requirements. The Hot Work Audit Form is used to record the audit with any improvements to be agreed and actioned by the area Manager.

Document Title:	<b>Bushfire Management Plan – Rix's Creek Mine</b>		Document Owner:	<b>Chris Knight</b>
Prepared By:	Chris Quinn	Print Date:	1-Apr-26	Version No: 1.3
Reviewed By:	Julius Harris-Payne	Review Frequency:	<b>As Required</b>	Issue Date: 1/04/2026
Approved By:	Brendon Clements			Page No: 18 of 35

**Bushfire Management Plan  
Rix's Creek North & Rix's Creek South**

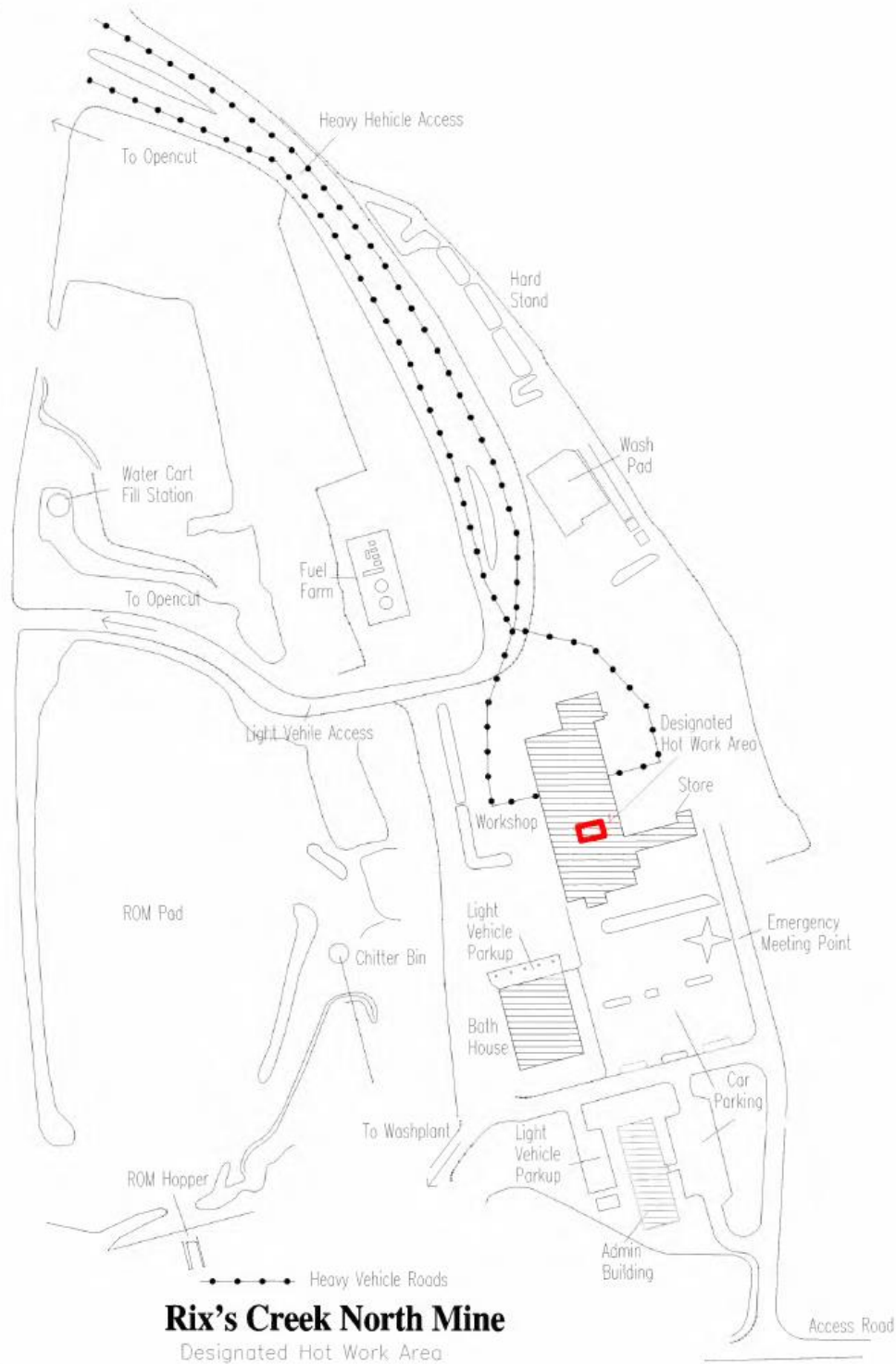
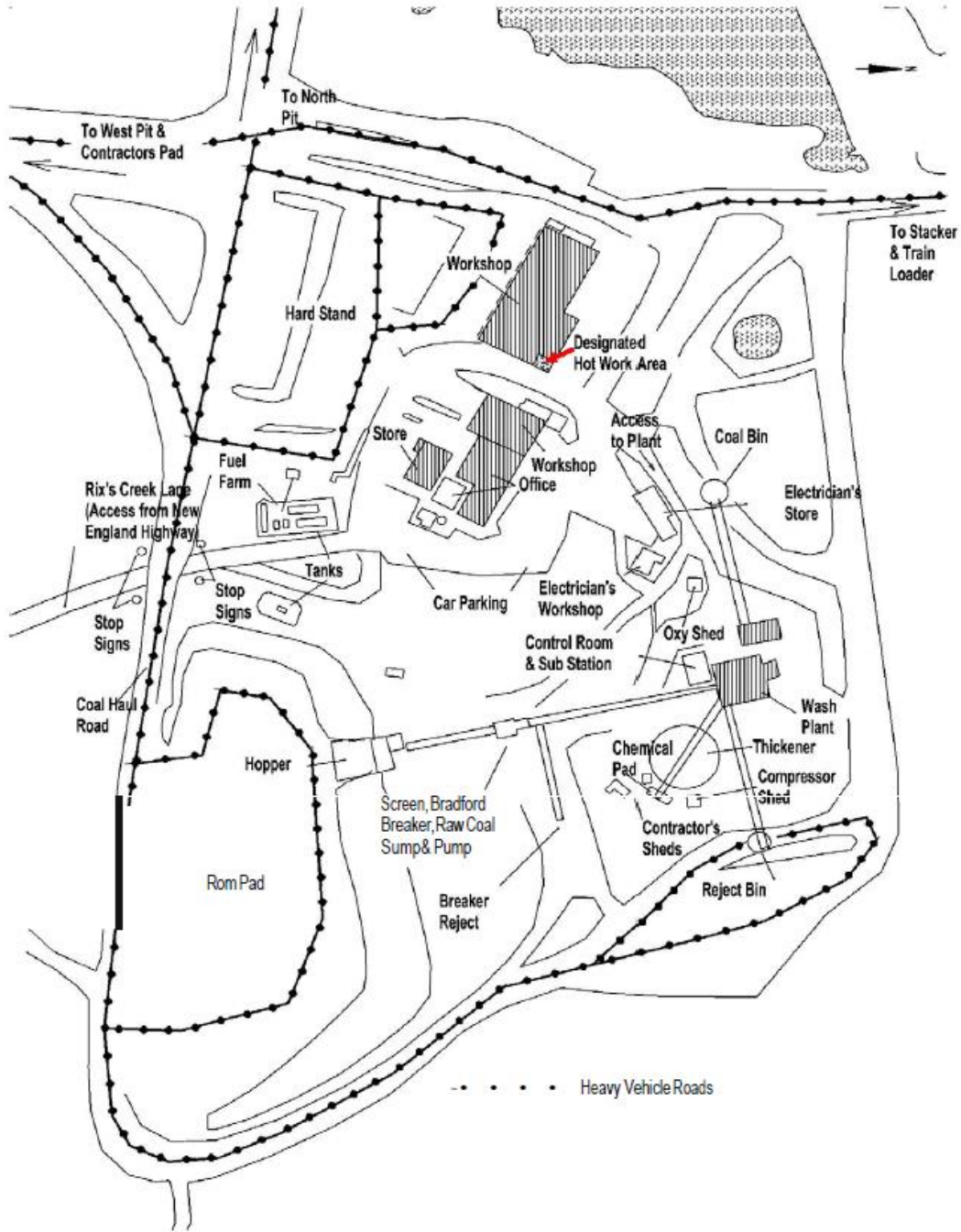

Figure 5 Rix's Creek North Designated Hot Work Area

Document Title:	<b>Bushfire Management Plan – Rix's Creek Mine</b>		Document Owner:	<b>Chris Knight</b>	
Prepared By:	Chris Quinn	Print Date:	1-Apr-26	Version No:	1.3
Reviewed By:	Julius Harris-Payne	Review Frequency:	<b>As Required</b>	Issue Date:	1/04/2026
Approved By:	Brendon Clements			Page No:	19 of 35

**Bushfire Management Plan  
Rix's Creek North & Rix's Creek South**



**RIX'S CREEK SOUTH 'DESIGNATED HOT WORK AREA'**

Figure 6 Rix's Creek North Designated Hot Work Area

Document Title:	<b>Bushfire Management Plan – Rix's Creek Mine</b>		Document Owner:	<b>Chris Knight</b>	
Prepared By:	Chris Quinn	Print Date:	1-Apr-26	Version No:	1.3
Reviewed By:	Julius Harris-Payne	Review Frequency:	<b>As Required</b>	Issue Date:	1/04/2026
Approved By:	Brendon Clements			Page No:	20 of 35

## 8.1 HOT WORK PERMIT

If a Hot Work Permit is required, the Supervisor ensures that the following has been addressed (either by themselves or others):

- Work area is inspected;
- Assists the permit holder with completion of the Hot Work Permit;
- Approves the Hot Work Permit by signing it, and issues it to the Permit Holder
- Instructs all people associated with the task in the provisions of the Hot Work Permit, or instructs the Permit Holder do so, and ensures they also sign the Hot Work Permit, prior to work commencing;
- Verify the need for a Fire Watch during and after the Hot Work Task
- Work area is inspected after completion of the job.
- Closes the Hot Work Permit by signing it. NOTE: The order of preference for supervisors to sign and approve the permit is the;
  - Supervisor directly supervising the hot work task,
  - Mechanical supervisor for that area/location,
  - A Rix's Creek supervisor (e.g. electrical supervisor, OCE, etc.)

## 8.2 CIRCUMSTANCES WHEN 'HOT WORKS' ARE LIMITED OR PROHIBITED

### 8.2.1 HOT WORKS DURING FIRE BAN

During a Total Fire Ban period, the lighting, maintenance or use of any fire or class of fire in the open air is prohibited for such period or periods as may be specified in the ban.

For Mine Sites (RF Act 1997), an exemption is given to Mining Operations for fire lit, maintained or used in the open air in association with the cutting, welding and/or grinding apparatus which are being used for the purpose of the urgent and essential maintenance and repair of mining equipment provided that:

- The cutting, welding and/or grinding apparatus is used in a manner which will prevent the escape of fire, sparks or burning material from the site of the works; and
- Adequate firefighting equipment is provided at the site of works to prevent the escape or spread of the fire.

RCM considers urgent and essential Hot Works to be Hot Works that are required so that the production of coal continues at standard production levels.

The Total Fire Ban section of the Hot Works Permit must be completed on a day that is declared a Total Fire Ban.

Document Title:	<b>Bushfire Management Plan – Rix's Creek Mine</b>		Document Owner:	<b>Chris Knight</b>	
Prepared By:	Chris Quinn	Print Date:	1-Apr-26	Version No:	1.3
Reviewed By:	Julius Harris-Payne	Review Frequency:	<b>As Required</b>	Issue Date:	1/04/2026
Approved By:	Brendon Clements			Page No:	21 of 35

RCM requires a Hot Works Permit, signed by a supervisor, to be correctly completed and implemented for all work that is considered urgent and essential enough to take place outdoors through a Total Fire Ban.

**8.2.2 HOT WORK IN HAZARDOUS AREAS**

A Hot Work Hazardous Area is an area where the conduct of Hot Work may create a risk to personal safety. Where possible, the requirement to conduct Hot Work within a Hazardous Area should be eliminated.

No Hot Work will be conducted within a Hazardous Area unless a Hot Work Permit has been completed and signed by a person appointed as a Rix's Creek supervisor (this includes contractor supervisors who have been appointed as a Supervisors on Rix's Creek sites) and the controls identified in the Hot Work Permit have been implemented.

No Hot Work is to be conducted on any rim whilst a tyre is fitted, or in an area where the work may cause heating of the tyre or rim.

Areas deemed to be Hazardous Areas include:

- Work on Diesel or Bulk Oil stores, pumps/ fittings etc;
- Work on mobile diesel tank, fuel cart, machine fuel tank;
- Within 3m of flammable gas cylinder store area or acetylene bottle banks;
- Where transfer of heat or spark can occur into a drum/ opening suspected to have held chemicals or fuels;
- Within 4m of the Frother and/ or Collector dosing pumps;
- Within 1.5m of the Frother and/ or Collector line fittings;
- Within 3m of petrol bowser or length of hose +1m past nozzle (whichever is greatest);
- Within 3m of a flammable goods store area (solvents, adhesives, etc);
- Within 10m of Explosives Magazine;
- Within the footprint of a Coal Bin;
- Within a Confined Space;
- Within the Reclaim Tunnel;
- Work on or above Coal Stockpile Area;
- Within the bunded area of the Frother and/ or Collector storage tanks;
- Where heat created in the work piece or surrounding area could create pressure;
- Work on equipment on or adjacent to a loaded or partially loaded blast pattern;
- Work on a rim whilst a tyre is fitted, or in an area where the work may cause heating of the tyre or rim;
- Work within 3m of Excavator centre/ swivel joint.

Document Title:	<b>Bushfire Management Plan – Rix's Creek Mine</b>		Document Owner:	<b>Chris Knight</b>	
Prepared By:	Chris Quinn	Print Date:	1-Apr-26	Version No:	1.3
Reviewed By:	Julius Harris-Payne	Review Frequency:	<b>As Required</b>	Issue Date:	1/04/2026
Approved By:	Brendon Clements			Page No:	22 of 35

---

### 8.3 HOT WORKS SAFETY MEASURES

---

Prior to conducting any Hot Work, the area will be inspected by competent personnel. The area to be inspected is within a 15m radius including above and below the work area. This inspection will include where practical:

- All flammable materials such as rags, oils, etc. are either removed from the inspection area, or controlled to mitigate risk of fire before conducting hot work;
- Clear or soak dry grass or scrub in surrounding area if required;
- Locate the nearest firefighting equipment;
- Ventilation is adequate to ensure atmosphere does not contain flammable vapours;
- Combustibles are removed from the opposite side of walls;
- Wall and floor openings are covered;
- Fire equipment is available within 10m of the work area;
- Housekeeping is conducted. Housekeeping may include sweeping of floors, check walls and horizontal surfaces for dust. If outdoors, Housekeeping will include clearing away combustible materials such as vegetation, sawdust, wooden pallets and soak the area if required;
- Disconnect (isolate) electrical sources and other energy sources that may create a hazard;
- Communications and emergency preparedness is in place;
- Access and emergency egress is available;
- In areas subject to people movement, leads and hoses are to be suspended clear of people or run adjacent to kick plates or in similar out of the way positions. Where leads and hoses need to be crossed by people/ equipment moving about, extra protection should be used to prevent insulation damage, e.g. Cable Bridge or other suitable equipment.

## 9. BUSHFIRE MANAGEMENT AND EMERGENCY RESPONSE

---

### 9.1 BUSHFIRE EMERGENCY RESPONSE PROCEDURE

---

If a bushfire is identified on site the general response to a fire related emergency is followed:

- The first priority, when a fire is discovered, is to ensure personal safety and the safety of any other people in the area.
- Where a person assesses that the fire is capable of being extinguished by their own action and with the equipment available within the immediate vicinity, they should attempt to extinguish the fire.
- Report emergency over the two- way radio to initiate emergency response procedure
  - Emergency! Emergency! Emergency!

Document Title:	<b>Bushfire Management Plan – Rix's Creek Mine</b>		Document Owner:	<b>Chris Knight</b>
Prepared By:	Chris Quinn	Print Date:	1-Apr-26	Version No: 1.3
Reviewed By:	Julius Harris-Payne	Review Frequency:	<b>As Required</b>	Issue Date: 1/04/2026
Approved By:	Brendon Clements			Page No: 23 of 35

## Bushfire Management Plan Rix's Creek North & Rix's Creek South

- Your name
- Your location
- Type of emergency
- Type of assistance require
- Stay near the radio or the phone and await further instruction

In the event of a bushfire emergency at RCM the RFS will be engaged. Once engaged the RFS have the lead role in emergency response for the RCM site. However, due to the potential presence of gases and explosive material, NSW Fire and Rescue (NSWF&R) may also be involved if a HAZMAT is declared. Any HAZMAT event will be coordinated between NSWF&R and RFS.

In the event of a bushfire emergency at RCM, RCM will assist the RFS where possible. In the event of a small fire, RCM may attempt to suppress a fire with portable fire extinguishers and earth moving machinery. A site water cart may also be deployed. In the event of a bushfire occurring on the BCC site the operational priorities are for:

- The safety of all personnel, followed by;
- The protection of assets

### 9.1.1 RFS AND EMERGENCY SERVICES ACCESS POINTS

Roads surrounding RCM include the New England Highway, Rix's Creek Lane, Maison Dieu Road, Belmadar Way, Bridgman Road, Stoney Creek Road and Middle Falbrook Road. These roads provide access to areas of the mine site and allow two-way movement of fully loaded firefighting trucks.

There are a number of unsealed tracks within the mine site that provide additional firefighting access to emergency services. In the event of an emergency, designated RCM personnel will liaise with RFS crews and coordinate the most appropriate meeting point where designated RCM personnel will meet RFS crews and provide escort to the most suitable point for accessing the bushfire. Additional traffic control personnel may be assigned to assist arrival of further equipment and personnel. Figure 4 identifies Entry Access points/ Gates for emergency service use, Access Entry Points are numbered for RFS reference. During an emergency, emergency services including RFS have access to several sources of water that can be used for bushfire fighting purposes.

## 9.2 EMERGENCY RESPONSE PERSONEL

Due to the proximity of the Rix's Creek Mine to local firefighting expertise, the general response to a fire of any significance is to call out the local fire brigade/ rural fire service.

The initial response to a fire and resources for dealing with minor fires is provided by the Rix's Creek site firefighting personnel including;

- General Workforce

Document Title:	<b>Bushfire Management Plan – Rix's Creek Mine</b>		Document Owner:	<b>Chris Knight</b>
Prepared By:	Chris Quinn	Print Date:	1-Apr-26	Version No: 1.3
Reviewed By:	Julius Harris-Payne	Review Frequency:	<b>As Required</b>	Issue Date: 1/04/2026
Approved By:	Brendon Clements			Page No: 24 of 35

**Bushfire Management Plan  
Rix's Creek North & Rix's Creek South**

The general workforce are familiar with the workings of the operation, have completed relevant competencies.

- Fire Team

A fire team is established at the Mine and contains representatives from all shifts. The team is familiar with the workings of the operation and can operate the Fire Tender (Water Cart) and have conducted the relevant training.

- Fire Officer/s

The Manager has appointed a Fire Officer/s who is familiar with the workings of the mine and has completed relevant training course as recognised by the Board of Fire Commissioners of NSW. The Fire Officer/s responsibilities include ensuring that there is suitable equipment to respond to any fires on the site and ensure that all fire-fighting equipment is inspected and maintained as per the relevant Australian Standard and/ or manufacturers' guidelines.

### 9.3 EMERGENCY CONTACTS

Emergency contact details for 24 hour site contacts are provided in the table below. In addition to emergency services and NSW RFS contact details.

Contact	Contact Details
Rix's Creek Mine Administration Number	+61 2 6578 8888
Emergency	000
NSW RFS Bush Fire Information Line	1800 679 737
NSW RFS Fire Control Centre – Hunter Valley District	02 6575 1200

### 9.4 EMERGENCY EVACUATION

In the event that there is a need to evacuate the general work areas as a result of an emergency involving Bushfire the following emergency evacuation plan must be followed.

All personnel (including contractors and visitors) not required as part of the emergency response activities must assemble at the designated Exclusion Zone Assembly Area. Relevant Site Contacts take responsibility (as far as possible without endangering themselves or others) of contractors and visitors.

The following emergency evacuation plan identifies the locations and relevant exclusion zones of bulk flammable liquids and materials.

Document Title:	<b>Bushfire Management Plan – Rix's Creek Mine</b>	Document Owner:	<b>Chris Knight</b>
Prepared By:	Chris Quinn	Print Date:	1-Apr-26
Reviewed By:	Julius Harris-Payne	Version No:	1.3
Approved By:	Brendon Clements	Issue Date:	1/04/2026
	Review Frequency:		Page No: 25 of 35

Bushfire Management Plan  
Rix's Creek North & Rix's Creek South

---

The following emergency evacuation plan is in accordance with the *Guidelines for the Preparation of Emergency/Evacuation Plans* (RFS) and Australian Standard AS 3745 *Planning for Emergencies in Facilities*.

Document Title:	<b>Bushfire Management Plan – Rix's Creek Mine</b>		Document Owner:	<b>Chris Knight</b>
Prepared By:	Chris Quinn	Print Date:	1-Apr-26	Version No: 1.3
Reviewed By:	Julius Harris-Payne	Review Frequency:	<b>As Required</b>	Issue Date: 1/04/2026
Approved By:	Brendon Clements			Page No: 26 of 35

Bushfire Management Plan  
Rix's Creek North & Rix's Creek South



Figure 7 Rix's Creek Emergency Evacuation Plan and Location of Bulk Flammable Liquids and Materials

Document Title:	<b>Bushfire Management Plan – Rix's Creek Mine</b>		Document Owner:	<b>Chris Knight</b>	
Prepared By:	Chris Quinn	Print Date:	1-Apr-26	Version No:	1.3
Reviewed By:	Julius Harris-Payne	Review Frequency:	<b>As Required</b>	Issue Date:	1/04/2026
Approved By:	Brendon Clements			Page No:	27 of 35

## 9.5 SUPPORTING THE RFS

Management of all Rix's Creek owned lands must be undertaken in accordance with license conditions and legislation.

Under the RF Act (1997), the RFS has the power to direct landholders, including RCM, to undertake hazard reduction activities on their property.

It is the duty of the owner or occupier to follow direction of the RFS in order to prevent the occurrence of bush fires and minimise the danger of the spread of bushfires.

## 10. REPORTING

Annual reporting is through the Annual Review Report. Further regulatory reporting will be at the request of relevant authorities.

## 11. DOCUMENT REVIEW AND IMPROVEMENT

To ensure that this Plan is updated on a regular basis and to incorporate and recommend measures to improve the environmental performance of RCM this plan will be reviewed by RCM every three years.

## 12. ROLES AND RESPONSIBILITIES

Table 3 Roles and responsibilities

ROLE	RESPONSIBILITY
<b>Operations Manager</b>	<ul style="list-style-type: none"> <li>Provide adequate resources to ensure the implementation of this plan.</li> <li>Appoint a Fire Officer</li> </ul>
<b>Environmental Manager or delegate</b>	<ul style="list-style-type: none"> <li>Ensure this BMP is reviewed and updated as necessary</li> <li>Ensure this BMP is in accordance with the operations Development Consent Conditions</li> <li>Ensure the implementation of this BMP</li> </ul>
<b>Environmental Staff</b>	<ul style="list-style-type: none"> <li>Understand and comply with the requirements as specified within this plan</li> <li>Coordinate the re-establishment of firebreaks annually or as required</li> <li>Coordinate the maintenance of the lawns, gardens and road verges around the access road and office buildings</li> </ul>

Document Title:	<b>Bushfire Management Plan – Rix's Creek Mine</b>	Document Owner:	<b>Chris Knight</b>
Prepared By:	Chris Quinn	Print Date:	1-Apr-26
Reviewed By:	Julius Harris-Payne	Version No:	1.3
Approved By:	Brendon Clements	Issue Date:	1/04/2026
	Review Frequency:		Page No:
		<b>As Required</b>	28 of 35

**Bushfire Management Plan  
Rix's Creek North & Rix's Creek South**

	<ul style="list-style-type: none"> <li>• Visually monitor fuel loads within and around the complex</li> <li>• Coordinate the maintenance of 4WD access roads to isolated pockets of vegetation</li> <li>• Undertake activities in accordance with the operations Development Consent Conditions.</li> <li>• Monitor weather conditions</li> </ul>
<p><b>Fire Officer</b></p>	<ul style="list-style-type: none"> <li>• Shall understand and comply with the requirements as specified within this plan</li> <li>• Liaise with the Singleton Rural Fire Service regarding in fires in or adjoining lands properties</li> <li>• Ensuring that all fire-fighting equipment is inspected and maintained as per the relevant Australian Standard and/ or manufacturers' guidelines;</li> <li>• Maintaining a record of the condition of the equipment</li> <li>• Ensuring that any damaged/ defective fire-fighting equipment is repaired/ replaced as soon as practicable. If it is likely that there may be a significant delay regarding repair/ replacement, the Fire Officer reports the matter to the Manager and other suitable arrangements are made;</li> <li>• Investigating any complaint or report made concerning the condition of any firefighting equipment;</li> <li>• Ensuring that structured fire-fighting and/ or emergency training and/ or rescue training is carried out for fire team and general workforce (as appropriate);</li> <li>• Coordinating an annual emergency response exercise and/ or annual brief of an actual emergency;</li> <li>• Liaising as appropriate with the relevant external authorities (emergency services) regarding the establishment of the System and its ongoing effectiveness.</li> </ul>
<p><b>All Mine Workers, Contractors and Visitors</b></p>	<ul style="list-style-type: none"> <li>• Shall understand and comply with the requirements of this plan as educated via The Bloomfield Group Employee Induction.</li> </ul>

Document Title:	<b>Bushfire Management Plan – Rix's Creek Mine</b>	Document Owner:	<b>Chris Knight</b>
Prepared By:	Chris Quinn	Print Date:	1-Apr-26
Reviewed By:	Julius Harris-Payne	Version No:	1.3
Approved By:	Brendon Clements	Issue Date:	1/04/2026
	Review Frequency:		Page No: 29 of 35
			<b>As Required</b>

## 13. DEFINITIONS

*Table 4 Definitions*

Term	Definition
Assets	Anything valued by the operation or stakeholders and includes houses, buildings, infrastructure, equipment, crops, livestock, cultural sites, heritage buildings and places, the environment, businesses, and forests that may be at risk from bushfire.
Asset Protection Zone (APZ)	A mown or slashed area around an asset designed to reduce the potential for flame, radiant heat or embers to ignite a structure and to create a defendable space where occupants or fire-fighters can protect that asset.
Bushfire	A general term used to describe fire in vegetation, includes grass fire.
Bushfire Hazard	The potential severity of a bushfire, which is determined by fuel load, fuel arrangement and topography under a given climatic condition.
Bush Fire Risk	The chance of a bushfire igniting, spreading and causing damage to the community of the assets they value.
Bushfire Threat	Potential bushfire exposure of an asset due to the proximity and type of a hazard, the slope on which the hazard is situated and the weather conditions.
Competent	A person who has acquired, through training, qualification, or experience, or a combination of these, the knowledge and skills qualifying that person to perform the task required.
Fire Depot	Demarcated and dedicated storage area for firefighting equipment and accessories.
Fire Fighting Authorities	The NSW Rural Fire Service, NSW Fire Brigades, the National Parks and Wildlife Service and Forests NSW.
Fuel	Any material such as grass, leaf litter and live vegetation which can be ignited and sustains a fire.
Hazard	A source or a situation with a potential for harm in terms of human injury or ill-health, damage to property, damage to the environment, or a combination of these.
HAZMAT	an abbreviation for "hazardous materials"—substances in quantities or forms that may pose a reasonable risk to health, property, or the environment.

Document Title:	<b>Bushfire Management Plan – Rix's Creek Mine</b>		Document Owner:	<b>Chris Knight</b>	
Prepared By:	Chris Quinn	Print Date:	1-Apr-26	Version No:	1.3
Reviewed By:	Julius Harris-Payne	Review Frequency:	<b>As Required</b>	Issue Date:	1/04/2026
Approved By:	Brendon Clements			Page No:	30 of 35

**Bushfire Management Plan  
Rix's Creek North & Rix's Creek South**

Risk	The likelihood and consequence of that injury or harm occurring.
Risk/Hazard	The overall process of estimating the magnitude of risk and deciding what actions shall be taken to control the risk. (Ref: AS/NZS 4804: 2001)
Strategic Fire Management Zone (SFMZ)	An area where slashing is conducted to reduce fuel loads with the aim of reducing the speed and intensity of a future bushfire. The SFMZ aims to reduce the risk of fires spreading within the site and assists in stopping fires spreading on or to adjoining lands.
Land Management Zone (LMZ)	Lands managed to meet relevant land management objectives where APZs or SFAZs are not appropriate. Relevant examples include land identified for mining operations, biodiversity conservation or by leases for residential or agricultural purposes.
Major Bushfire	A bushfire which requires the attendance of multiple brigades, or causes damage to property or injury to one or more persons.
Prescribed burn	A controlled burn undertaken to meet a defined fuel management purpose with a prescription outlining intended frequency, fire behaviour and fuel reduction targets.

## 14. REFERENCES

- NSW Work Health and Safety (Mines) Act 2013
- NSW Work Health and Safety (Mines) Regulation 2014
- NSW Work Health & Safety Act 2011
- NSW Work Health and Safety Regulations 2011
- Rural Fires Act, (1997 RFA)
- Rural Fires Regulation, (1997 RFR)
- Planning for Bush Fire Protection (RFS, 2006) guideline
- Guidelines for the Preparation of Emergency/Evacuation Plans (RFS)
- Australian Standard AS 3745 Planning for Emergencies in Facilities

Document Title:	<b>Bushfire Management Plan – Rix's Creek Mine</b>		Document Owner:	<b>Chris Knight</b>	
Prepared By:	Chris Quinn	Print Date:	1-Apr-26	Version No:	1.3
Reviewed By:	Julius Harris-Payne	Review Frequency:	<b>As Required</b>	Issue Date:	1/04/2026
Approved By:	Brendon Clements			Page No:	31 of 35

## 15. APPENDICIES

---

### 15.1 PLANNING FOR BUSHFIRE PROTECTION (RFS, 2006)

---

Document Title:	<b>Bushfire Management Plan – Rix's Creek Mine</b>		Document Owner:	<b>Chris Knight</b>	
Prepared By:	Chris Quinn	Print Date:	1-Apr-26	Version No:	1.3
Reviewed By:	Julius Harris-Payne	Review Frequency:	<b>As Required</b>	Issue Date:	1/04/2026
Approved By:	Brendon Clements			Page No:	32 of 35

A Guide for Councils, Planners, Fire Authorities and Developers

planning for  
**bush fire protection**  
protection



NSW RURAL FIRE SERVICE

2006

© Copyright 2006 held by the NSW Rural Fire Service. Apart from any use as permitted under the Copyright Act 1968, no part may be reproduced by any process without prior written permission from the NSW Rural Fire Service.

ISBN 0 9751033 2 6

**Acknowledgement:**

The NSW Rural Fire Service acknowledges the significant contribution to this document made by those who commented upon the publicly exhibited draft. The Service also acknowledges the staff of the Department of Planning for their collaborative efforts in producing *Planning for Bush Fire Protection*. The NSW Rural Fire Service also acknowledges the contribution made by the Planning for Bush Fire Protection Review Panel through the period of review, and its guidance on the final document. Photos supplied by Brian Crane and CSIRO are gratefully acknowledged.

**Disclaimer:**

Any representation, statement opinion, or advice expressed or implied in this publication is made in good faith on the basis that the State of New South Wales, the NSW Rural Fire Service, its agents and employees are not liable (whether by reason of negligence, lack of care or otherwise) to any person for any damage or loss whatsoever which has occurred or may occur in relation to that person taking or not taking (as the case may be) action in respect of any representation, statement or advice referred to above.

*Prepared by NSW Rural Fire Service in cooperation with the Department of Planning*

# Foreword

This updated edition of *Planning for Bush Fire Protection* (PBP) is a milestone in the NSW Government's efforts to work jointly with local government and the private sector to link responsible planning and development control with the protection of life, property and the environment.

Bush fire is a major challenge for the community. It has been a natural part of our landscape for thousands of years and remains an ever-present threat.

In the period 24 December 2001 to 16 January 2002 bush fires caused the loss of 109 homes across New South Wales, with 40 others being damaged. Losses were particularly severe in Blue Mountains, Penrith, Wollondilly, Shoalhaven and Hawkesbury local government areas. More recently, in 2003, the devastating fires of the ACT severely damaged the suburbs of Duffy and Chapman, with some 500 homes being lost.

The NSW Rural Fire Service has a statutory obligation to protect life, property and the natural environment through fire suppression and fire prevention. Improved land use planning decisions for developments in bush fire prone areas are intrinsic to the fire management and environmental protection strategies of the Service.

Following the Sydney bush fires in 2001/2002 a Joint Parliamentary Inquiry was established and, in its 28 June 2002 report, endorsed the release of the updated 2001 version of PBP.

The report also recommended that: "the PBP Guideline continue to be reviewed, and updated as new research about fire impact on buildings becomes available, and reissued or affirmed at least every two years."

The changes in this document reflect the legislative amendments that came into effect on 1 August 2002, through the *Rural Fires and Environmental Assessment Legislation Amendment Act 2002*, as well as changes to the *Building Code of Australia*.

This substantially revised 2006 edition of PBP is intended for use by councils, town planners, NSW fire authorities, developers, planning and bush fire consultants, surveyors, and building practitioners (including accredited certifiers).

Key features of the revised edition include the emphasis on a performance based approach to development through focusing on safer outcomes rather than simply meeting prescriptive requirements.

This approach to planning allows for considerable flexibility and innovation that links the bush fire hazard for a site with the implementation of appropriate bush fire protection measures.

Types of appropriate measures include suitable defensible space; access considerations; vegetation management; on-site emergency management arrangements; water supply provisions and site assessment for building construction requirements using AS 3959-1999.

PBP also provides the necessary planning framework for developments in rural and urban areas close to land likely to be affected by bush fire.

PBP is also applicable to the subdivision of land for residential and rural-residential purposes and those developments which are considered a special fire protection purpose. These include, developments under State Environmental Planning Policy Seniors Living, schools, hospitals, and tourism developments. PBP recognises that these developments may present their own individual peculiar difficulties at times of an emergency.

Finally, PBP expands the considerations for infill developments - a dwelling within an existing allotment - and for the first time establishes the bush fire planning objectives for industrial, commercial and warehousing types of development.

This edition of PBP and the application of its principles will significantly assist all those involved in planning developments in bush fire prone areas and will also help the Service to fulfill its charter of protecting life, property and our fragile environment.

I commend *Planning for Bush Fire Protection 2006* to you.



A handwritten signature in black ink that reads "Tony Kelly".

**The Hon. Anthony Bernard KELLY, MLC**  
Minister for Emergency Services

## List of Abbreviations

<b>APZ</b>	Asset Protection Zone
<b>B &amp; Bs</b>	Bed and Breakfast establishments
<b>BCA</b>	Building Code of Australia
<b>BFSA</b>	Bush Fire Safety Authority
<b>BPA</b>	Bush Fire Prone Area (also bush fire prone land)
<b>BPMs</b>	Bush Fire Protection Measures
<b>BPL Map</b>	Bush Fire Prone Land Map
<b>CC</b>	Construction Certificate
<b>DA</b>	Development Application
<b>DCP</b>	Development Control Plan
<b>DEC</b>	Department of Environment and Conservation
<b>EP&amp;A Act</b>	<i>Environmental Planning and Assessment Act 1979</i>
<b>ESD</b>	Ecologically sustainable development
<b>FDI</b>	(Forest) Fire Danger Index (Also FFDI)
<b>IPA</b>	Inner Protection Area
<b>KNP</b>	Kosciuszko National Park
<b>kW/m<sup>2</sup></b>	kilowatts per square metre (being a measure of radiant heat)
<b>LEP</b>	Local Environment Plan
<b>OPA</b>	Outer Protection Area
<b>PBP</b>	<i>Planning for Bush Fire Protection</i> (this document)
<b>RF Act</b>	<i>Rural Fires Act 1997</i>
<b>RF Regulation</b>	<i>Rural Fires Regulation</i>
<b>RFS</b>	NSW Rural Fire Service
<b>RHF</b>	Radiant Heat Flux
<b>ROS</b>	Rate of Spread
<b>SEPP</b>	State Environmental Planning Policy
<b>SFPP</b>	Special Fire Protection Purpose

# contents

FOREWORD .....	I
LIST OF ABBREVIATIONS .....	II
<b>CHAPTER 1 PBP AND YOU</b>	
1.1 Introduction .....	1
1.2 How to comply with PBP .....	1
1.2.1 What needs to be submitted .....	1
1.2.2 How will development be assessed .....	1
1.3 Relationship of the Building Code of Australia (BCA) to PBP .....	3
<b>CHAPTER 2 THE LEGAL FRAMEWORK</b>	
2.1 <i>Environmental Planning and Assessment Act, 1979</i> .....	4
2.2 Bush Fire Prone Land Mapping .....	4
2.3 Preparation of LEPs and DCPs .....	4
2.4 The development assessment framework and structure of PBP .....	5
2.5 Major Projects .....	6
2.6 Construction Provisions: The BCA and AS 3959 .....	7
2.7 <i>Rural Fires Act, 1997</i> .....	7
<b>CHAPTER 3 THE BUSH FIRE PROTECTION MEASURES</b>	
3.1 Bush Fire Protection Measures .....	9
3.2 The Bush Fire Protection Measures (BPMs) in combination .....	12
3.3 Exceptional circumstances for APZs .....	13
<b>CHAPTER 4 PERFORMANCE BASED CONTROLS</b>	
4.1 Planning controls for residential and rural residential subdivisions .....	15
4.1.1 What is subdivision? .....	15
4.1.2 Specific Objectives for Subdivisions .....	17
4.1.3 Standards for Bush Fire Protection Measures for Residential and Rural Residential Subdivisions .....	18
4.2 Planning controls for Special Fire Protection Purposes .....	28
4.2.1 Introduction .....	28
4.2.2 Types of Special Fire Protection Purpose Developments .....	28
4.2.3 Specific Objectives for Special Fire Protection Purpose Developments .....	28
4.2.4 Matters for consideration for specific SFPPs .....	28
4.2.5 SFPPs as infill .....	30
4.2.6 Applying SFPP objectives to other types of development .....	31
4.2.7 Standards for Bush Fire Protection Measures for Special Fire Protection Developments .....	32
4.3 Planning controls for infill and other developments on bush fire prone land .....	40
4.3.1 Introduction .....	40
4.3.2 Specific Objectives for infill .....	40
4.3.3 Consultation with the RFS .....	41
4.3.4 The role of construction standards for residential infill .....	41
4.3.5 Specifications & Requirements for Bush Fire Protection Measures for Infill Development. .	42
4.3.6 PBP and other development .....	45

# contents

## APPENDICES

<b>Appendix 1</b> Key Legislation Relating to Bush Fire Prone Lands and Development Assessment .....	47
A1.1 Section 79BA - <i>Environmental Planning and Assessment Act 1979</i> .....	47
A1.2 Section 146 - <i>Environmental Planning and Assessment Act 1979</i> .....	47
A1.3 Section 100B - <i>Rural Fires Act 1997</i> - Bush Fire Safety Authorities .....	47
A1.4 Schedule 4 – EP&A Reg 11 - Bush fire prone land .....	48
A1.5 Clause 46 - <i>Rural Fires Regulation 2002</i> - Application for bush fire safety authority.....	48
A1.6 Clause 46A - <i>Rural Fires Regulation 2002</i> - Development excluded from requirements for bush fire safety authority .....	48
A1.7 Clause 46B - <i>Rural Fires Regulation 2002</i> - Additional special fire protection purposes for which bush fire safety authority required.....	49
A1.8 Classifications (of Buildings) – Volume 1, <i>Building Code of Australia (2006)</i> .....	49
<b>Appendix 2</b> . Determining Asset Protection Zones.....	50
A2.1 Introduction .....	50
A2.2 Terminology.....	50
A2.3 Procedure .....	51
<b>Appendix 3</b> . Site Bush Fire Attack Assessment.....	59
A3.1 Introduction .....	59
A3.2 Application.....	59
A3.3 Basis of the site assessment methodology: radiant heat flux and required separation distances .....	59
A3.4 Site assessment methodology for determining level of bush fire attack .....	62
A3.5 Construction Considerations within the Flame Zone .....	66
<b>Appendix 4</b> . Submission Requirements for DAs on bush fire prone land .....	67
A4.1 For general development applications to be considered under section 79BA of the EP&A Act.....	67
A4.2 For integrated development applications under section 100B of the RF Act and section 91 of the EP&A Act.....	67
<b>Appendix 5</b> . Bush Fire Provisions - Landscaping and Property Maintenance.....	69
A5.1 Introduction .....	69
A5.2 Principles of Protection.....	69
A5.3 Principles of Landscaping Properties for Bush Fire Protection .....	70
A5.4 Vegetation Management.....	71
A5.5 Maintenance of Property .....	71
Dictionary.....	72
References and other Reading .....	74
NSW Fire (Weather) Areas .....	Inside rear cover

# Chapter 1 PBP and You.

## 1.1 Introduction

This new version of *Planning for Bush Fire Protection* (PBP) applies to all “development applications” on land that is classified as “bush fire prone land” (BPL), identified on a council’s BPL map.

The general principles underlying this document are :

- protection measures are governed by the degree of threat posed to a development;
- a minimum setback from a hazard is always required, i.e. a defendable space;
- the greater the setback from the hazard, the lower the subsequent bush fire protection construction standards required;
- the smaller the interface a development has fronting the bush fire threat, the less the opportunity for bush fire to threaten the development;
- bush fire protection measures (BPMs) are contained within the ‘overall’ development and not on adjoining lands, other than in exceptional circumstances (see section 3.3); and
- no development in a bush fire prone area can be guaranteed to be entirely safe from bush fires.

For development on BPL specific controls apply to residential/rural residential subdivision and “Special Fire Protection Purposes” (SFPPs) – those types of development specified in the legislation as requiring particular attention (including mandatory involvement of the Rural Fire Service) (see section 2.7).

Particular attention is also given to residential “infill” – new houses and alterations/additions in pre-existing subdivisions.

For “other development”, the aim/objectives of PBP apply (see below). The suite of bush fire protection measures will also be useful for developers and for assessment purposes.

BPMs will assist building survival during a bush fire. They will also contribute to the safety of firefighters and members of the community occupying or attempting to leave buildings during a bush fire.

They are also designed to take into account development potential, on-site amenity and environmental protection.

Figure 1.1 illustrates the process of using PBP in relation to a specific development proposal.

## 1.2 How to comply with PBP

### 1.2.1 What needs to be submitted

Development Applications to the consent authority (usually the relevant council) on bush fire prone land need to include a bush fire assessment report within their Statement of Environmental Effects, (see Appendix 4).

### Aim and Objectives of PBP.

All development on Bush Fire Prone Land must satisfy the aim and objectives of PBP.

The aim of PBP is to use the NSW development assessment system to provide for the protection of human life (including firefighters) and to minimise impacts on property from the threat of bush fire, while having due regard to development potential, on-site amenity and protection of the environment.

More specifically, the objectives are to:

- afford occupants of any building adequate protection from exposure to a bush fire;
- provide for a defendable space to be located around buildings;
- provide appropriate separation between a hazard and buildings which, in combination with other measures, prevent direct flame contact and material ignition;
- ensure that safe operational access and egress for emergency service personnel and residents is available;
- provide for ongoing management and maintenance of bush fire protection measures, including fuel loads in the asset protection zone (APZ); and
- ensure that utility services are adequate to meet the needs of firefighters (and others assisting in bush fire fighting).

Applicants must demonstrate to the RFS or the consent authority that proposals satisfy the broad aim and objectives of PBP, specific objectives for the development type and the performance criteria for the various proposed bush fire protection measures (BPMs). (See Figure 1.2)

For residential/rural-residential subdivision and “special fire protection purposes”, proposals must also comply with:

- the specific objectives in sections 4.1 and 4.2 respectively; and
- the performance criteria for each of the Bush Fire Protection Measures (BPMs) in sections 4.1 and 4.2 respectively.

For “infill development” (as defined), proposals must also comply with:

- the specific objectives in section 4.3; and
- the performance criteria in section 4.3.

### 1.2.2 How will development be assessed

This version of *Planning for Bush Fire Protection* (PBP) introduces a performance based approach, and identifies objectives and detailed performance criteria to satisfy desired outcomes.

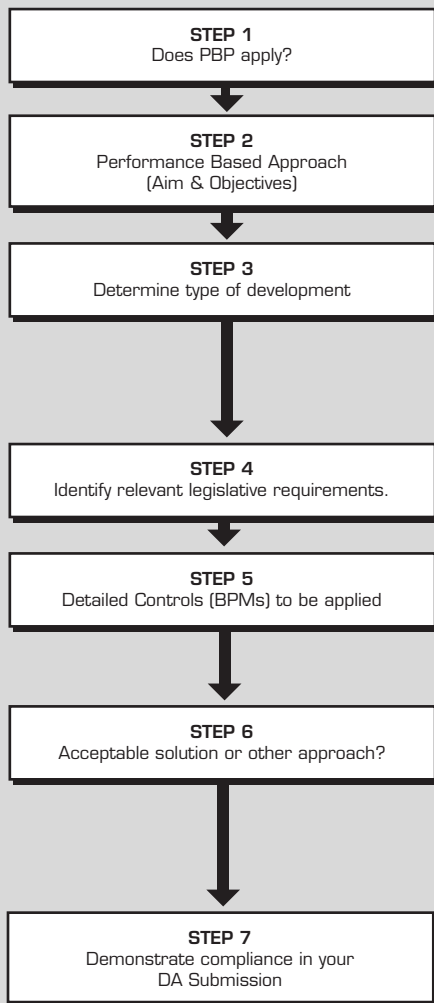

Figure 1.1 How to use PBP

**Check that the proposed development is on bush fire prone land (on certified bush fire prone land map). Maps are available at the relevant local Council.**

Read Chapter 1 which:

- explains the performance based approach, and
- lists the aim and objectives of PBP.

**Read Chapter 2 and determine whether the proposed development is:**

- residential or rural residential subdivision
- a “special fire protection purpose” – as defined or
- other development, such as residential infill, alterations and additions.

Determine whether the development is captured under section 79BA of the EP&A Act or s100B of the RF Act requiring a bush fire safety authority (BFSA).

Read Chapter 3 which explains:

- the nature of the BPMs; and
- any exceptional circumstances that might apply .

Read the relevant parts of Chapter 4 (4.1, 4.2 or 4.3), noting:

- Specific objectives and BPMs required (e.g. APZ, access).
- the intent, performance criteria and acceptable solutions for each BPM.
- the detailed Appendices referred to.

**Decide (for each measure) whether the Acceptable Solutions can be complied with, or that other means of satisfying the performance criteria are required. Consider an appropriate combination of measures.**

**Comply with the Submission Requirements (in Appendix 4) and provide evidence to support compliance with the “controls” and the aim and objectives of PBP.**

### (a) Performance Criteria for the Bush Fire Protection Measures

Performance criteria are the outcomes to be met for satisfying the BPMs.

The performance criteria can be satisfied in one of two different ways:

- use of the acceptable solutions; OR
- demonstrating another solution satisfying the specific objectives and performance criteria.

These performance criteria can be found in the Tables in Chapter 4 (Performance Based Controls).

Performance criteria allow applicants, consent authority and to the RFS to be flexible and innovative in responding development opportunities and constraints. In order to reach an acceptable siting and design solution, the criteria have been developed taking into account the range of circumstances across the State and recognising that no two sites or proposals are the same.

They also allow applicants, councils and the RFS to consider a broad range of issues and information, including community expectations, environmental protection and the application of new technologies.

### (b) Acceptable Solutions

PBP has identified some acceptable solutions which will satisfy the performance criteria.

Any variation from the acceptable solutions will require detailed justification to demonstrate how the performance criteria can be met through another method(s).

Figure 1.2 illustrates the relationship between the various components within PBP.

### (c) Proposing Alternative Solutions

Submissions proposing variations to acceptable solutions must provide substantiated evidence that the specific objectives and performance criteria can be met.

### 1.3 Relationship of the Building Code of Australia (BCA) to PBP

Development on BPL needs to meet the planning requirements of PBP as well as any bush fire construction requirements under the BCA. PBP recognises AS 3959 - 1999 as providing the deemed - to - satisfy arrangements for construction of certain classes of building.

#### (a) Residential Buildings and SFPPs

Where development occurs in a bush fire prone area, certain bush fire provisions of the BCA will apply (including various NSW variations) for buildings of classes 1, 2, 3, 4 and those class 9 buildings that are also a special fire protection purpose.

Where a development, submitted under section 79 BA of the EP&A Act, complies with the deemed-to-satisfy provisions of the BCA through AS 3959-1999 (using **Appendix 3 of PBP for the site assessment**), then the certifying authority can determine compliance and issue the relevant

construction certificate without referral to the RFS. Where an 'alternate solution' is offered for these classes of buildings, the RFS will consider the proposal under section 79BA (or section 100B in the case of a special fire protection purpose) and the certifying authority will issue the construction certificate in compliance with the development consent conditions.

#### (b) Other Classes of Buildings

For other classes of buildings (such as factories, shops and warehouses) BPMs will only apply at the development assessment stage. Consent will be determined on a case by case basis without the need to refer the development application to the RFS. However, if the council is concerned that the development does not meet the aim and objectives of PBP, then the matter may be referred to the RFS for its advice. The provisions under the BCA for fire safety will be accepted for bush fire purposes where the aim and objectives of PBP can be met (see section 1.1).

A description of the various classes of buildings can be found in Appendix 1 (see A1.6).

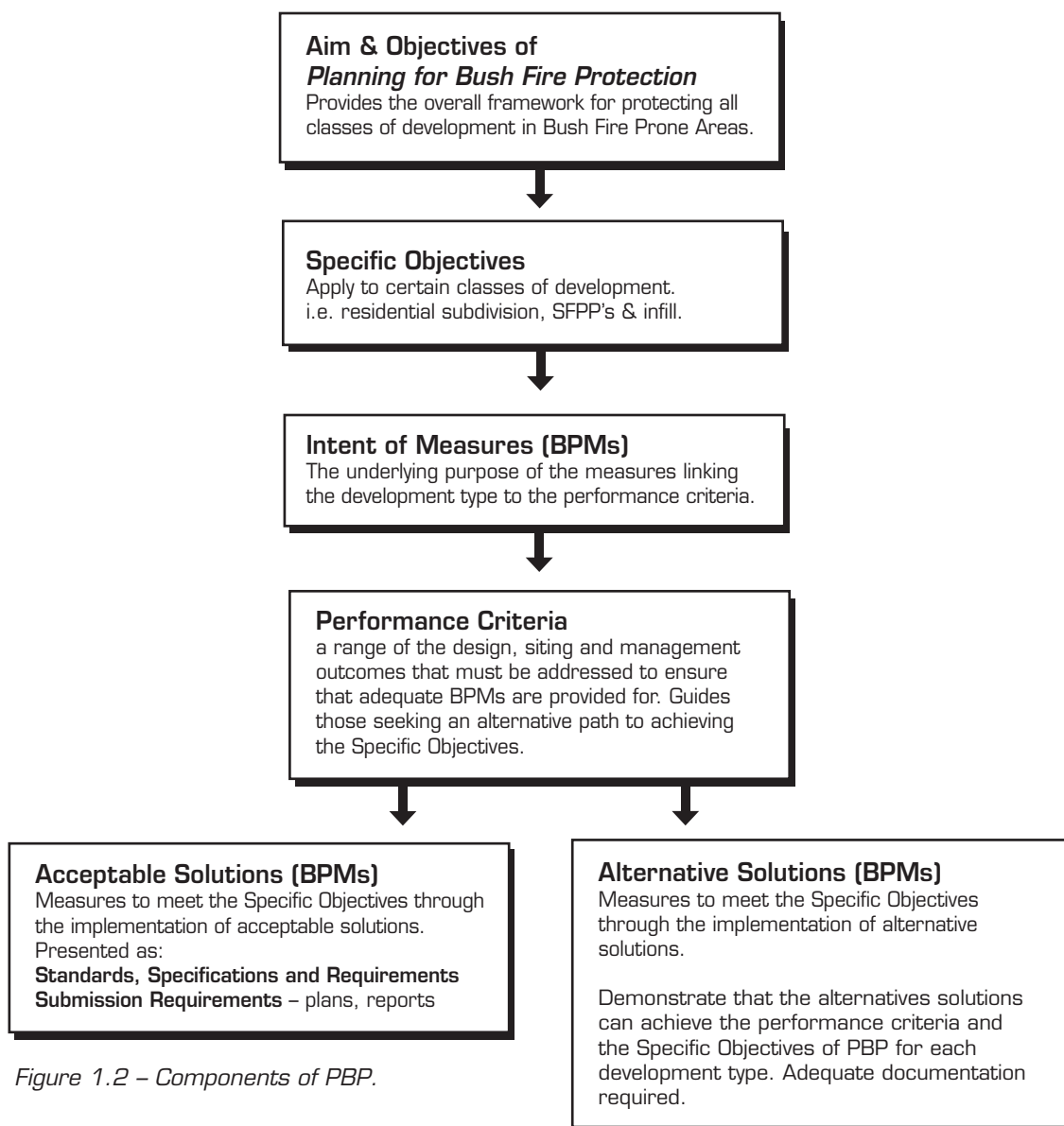

Figure 1.2 – Components of PBP.

## 2.1 Environmental Planning and Assessment Act, 1979

On 1 August 2002 the *Environmental Planning and Assessment Act 1979* (EP&A Act) and the *Rural Fires Act 1997* (RF Act) were both amended to enhance bush fire protection through the development assessment process.

*In broad terms, the planning considerations provide two main steps. These involve:*

- (a) *Strategic Planning through;*
- *the mapping of bush fire prone areas (BPAs);*
  - *determining suitable bush fire requirements during the preparation of a Local Environmental Plan/Development Control Plan; and*
  - *the identification of the extent to which land is bush fire prone.*
- (b) *Development assessment through;*
- *obtaining a bush fire safety authority for residential or rural-residential subdivision and special fire protection purpose developments in BPAs from the RFS;*
  - *seeking advice from the RFS in relation to infill and other developments in BPAs that cannot comply with the requirements of PBP; and*
  - *the application of additional requirements of the Building Code of Australia (BCA) in relation to construction standards for Class 1, 2, 3, 4 and some Class 9 buildings in BPAs.*

## 2.2 Bush Fire Prone Land Mapping

Bush fire prone land maps provide the trigger for the various development assessment provisions.

The identification of BPAs in NSW is required under section 146 of the EP&A Act. The Commissioner of the RFS designates, through separate guidelines, what constitutes a BPA and how it is to be mapped. Each council then prepares a map in accordance with the guidelines and submits the map for approval by the Commissioner.

These maps are updated at least every 5 years.

Guidelines for the mapping of BPAs can be obtained from the RFS website on [www.rfs.nsw.gov.au](http://www.rfs.nsw.gov.au).

## 2.3 Preparation of LEPs and DCPs

LEPs and DCPs are the best way of strategically achieving bush fire protection objectives. Inclusion of bush fire planning provisions in an LEP:

- gives weight to bush fire management planning principles, ensuring they are considered

- at subdivision and construction stages;
- can allow for sufficient space to be incorporated into land use zones for setbacks and adequate access for firefighting and evacuation; and
- controls inappropriate land uses in BPAs.

LEP amendments that affect BPAs need to address the planning principles of PBP (see below). Where appropriate the proposed land uses must be considered with respect to bush fire protection (including appropriate setbacks).

If a proposed amendment to land use zoning or land use affects a designated BPA, then the section 117(2) Direction No 19 must be applied (section 117 of the EP&A Act provides for the Minister for Planning to direct a council, in relation to the preparation of a draft LEP, to apply the planning principles specified in that direction).

The section 117 Direction No 19 requires councils to:

- consult with the Commissioner of the RFS under section 62 of the EP&A Act, and to take into account any comments by the Commissioner; and
- have regard to the planning principles of PBP below.

If a council proceeds with a draft LEP that does not comply with the provisions in the section 117 Direction, the council must obtain written advice from the Commissioner of the RFS to the effect that the RFS does not object to that non-compliance.

The requirement to review LEPs in accordance with the Standard LEP is an opportunity to consider appropriate uses on Bush Fire Prone Land as well as exempt and complying development provisions.

### *Planning Principles for Rezoning to Residential Land in Bush Fire Prone Areas*

- a. *Provision of a perimeter road with two way access which delineates the extent of the intended development;*
- b. *Provision, at the urban bushland interface, for the establishment of adequate asset protection zones for future housing;*
- c. *Specifying minimum residential lot depths to accommodate asset protection zones for lots on perimeter roads;*
- d. *Minimising the perimeter of the area of land, interfacing the hazard, which may be developed;*
- e. *Introduction of controls which avoid placing inappropriate developments in hazardous areas; and*
- f. *Introduction of controls on the placement of combustible materials in asset protection zones.*

## 2.4 The development assessment framework and structure of PBP

### (a) Types of Development

The EP&A Act establishes a system for requiring bush fire protection measures on bush fire prone land at Development Application (DA) stage as follows:

- (i) by requiring councils to map bush fire prone land. If any part of a development site is affected, special submission and assessment requirements may apply to the DA;
- (ii) Section 79BA of the EP&A Act requires compliance with PBP and, where an infill proposal does not comply with acceptable solutions in Chapter 4, consultation by the consent authority with the RFS is required; and
- (iii) Section 91 of the EP&A Act (in combination with the RF Act requirements for a section 100B Bush Fire Safety Authority) classes the following types of DA as Integrated Development:
  - residential and rural residential subdivision.
  - "Special Fire Protection Purposes" (SFPP).

Special procedures apply to these forms of development, though some exceptions to these may apply.

In summary, if a development site is on bush fire prone land, the requirements of this document will apply. For residential/rural residential subdivision and SFPPs, an Integrated DA approval must be obtained from the RFS (i.e. BFSA) is required.

The following table compares the two types of development application:

Non Integrated DA	Integrated DA
<ul style="list-style-type: none"> <li>• development site on bush fire prone land and not "integrated"</li> <li>• includes "infill" other than residential /rural subdivision or SFPP</li> <li>• s. 79BA EP&amp;A Act</li> </ul>	<ul style="list-style-type: none"> <li>• residential/rural residential subdivision or SFPP eg. - schools - hospitals - child care - nursing homes - seniors living</li> </ul>
<ul style="list-style-type: none"> <li>• possible consultation with RFS</li> </ul>	<ul style="list-style-type: none"> <li>• s. 91 EP&amp;A Act &amp; s. 100B RF Act</li> <li>• a BFSA from RFS required.</li> </ul>

There are also significant differences between the categories of uses that are "Integrated Developments". For instance:

Residential/Rural - Residential Subdivision	SFPPs e.g. Seniors Living, Tourist Facilities, Schools
<ul style="list-style-type: none"> <li>• building as a refuge</li> <li>• assume able-bodied residents with motor car available</li> <li>• APZ requirements based on Level 3 construction (AS 3959-1999). As a result APZ minimised (yield &amp; environmental protection maximised)</li> </ul>	<ul style="list-style-type: none"> <li>• assisted evacuation possible: higher exposure; working outdoors.</li> <li>• assume special needs of residents.</li> <li>• APZ requirements maximised and based on radiant heat exposure to emergency services</li> </ul>

DAs for integrated development do not all fit neatly into the categories above. Both categories can cover existing developments that do not conform to PBP. These situations can include, for instance, a block size that cannot accommodate the required APZ e.g. small scale subdivision, strata subdivision, B&Bs, extensions to other established SFPPs (such as schools, nursing homes or hospitals) and as such are treated as infill, having been previously approved prior to the introduction of PBP.

Development that is not integrated development is subject to section 79BA and covered as infill or other development on bush fire prone land.

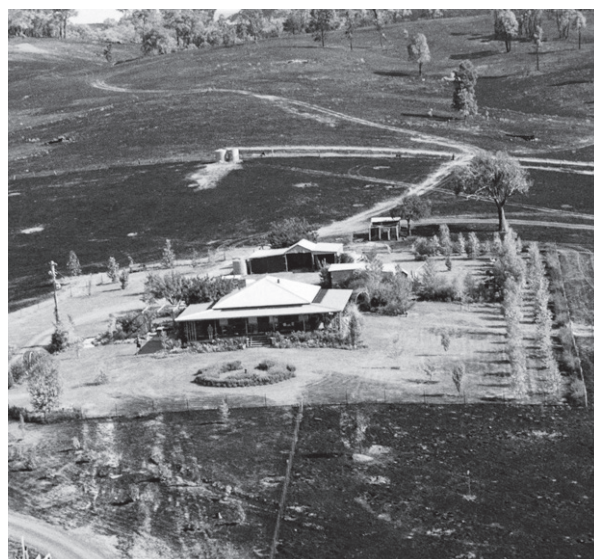

Effective bush fire protection measures protect a rural dwelling.

**(b) Section 79BA Consultation**

Section 79BA of the EP&A Act requires that a consent authority shall not grant approval for a development application for any purpose on bush fire prone land, unless it:

- is satisfied that the development conforms to the specifications and requirements of PBP; or
- consults with the RFS concerning measures to be taken to protect persons, property and the environment from danger that may arise from a bush fire.

The consent authority is only required to consult with the RFS under section 79BA when a proposed residential dwelling (i.e. infill) does not comply with the “acceptable solutions” within section 4.3 of this document or meet performance requirements.

The advice to the consent authority from the RFS is intended to provide a performance-based assessment to assist the consent authority in arriving at a determination of the proposal. Most s79BA matters are likely to be Class 1 or 2 buildings under the BCA or extensions or additions to these buildings.

**(c) Exempt and complying development**

**Exempt development** does not require development consent from a consent authority because it is considered to be of a specified class or description that has minimal environmental impact. Development consent is still required if it is to take place on land that is a critical habitat or is part of a wilderness area. Environmental planning instruments relevant to the proposed development such as an LEP provide for the types of development considered to be exempt development. If the relevant planning instrument provides that a form of development is ‘exempt development’ on bush fire prone land then the provisions of PBP do not apply however it must comply with the BCA in relation to bush fire.

**Complying development** is development which complies with specified predetermined development standards contained in the relevant environmental planning instrument. A Complying Development Certificate from a Certifying Authority such as the local council or an accredited certifier must be obtained (Refer to s76A and ss84-87 of the EP&A Act) A Complying Development Certificate is considered to be a form of development consent which requires a Construction Certificate prior to the commencement of work. Environmental planning instruments relevant to the proposed development such as a Local Environmental Plan provide for the types of development considered to be complying development. Complying development

would normally be exempted from the requirements of s79BA by virtue of an exception contained in s77 of the EP&A Act.

However, residential buildings (such as Classes 1, 2 and 3 under the BCA), if classified as complying development under the relevant planning instruments and located on bush fire prone land, must also comply with the BCA. This requirement is satisfied by following the site assessment methodology in Appendix 3 of PBP (and the construction requirements in section 3 of AS 3959-1999) which is adopted as the New South Wales Variation to the BCA.

*Planning authorities should carefully consider the types of exempt and complying development that are permitted in bush fire prone land in their area when drafting any planning instruments so that the issue of bush fire is adequately addressed.*

Residential/rural residential subdivision and SFPPs are integrated development under the EP&A Act (and require a bush fire safety authority under the RF Act). Development requiring a BFSA is not considered to be complying development, despite its classification in any LEP.

**(d) Planning Certificates (Section 149)**

Planning certificates provide information on the development potential of a parcel of land including any planning restrictions that apply.

A person can apply to a council for a Planning Certificate under section 149 of the EP&A Act on any land within the council area. The certificate will detail matters relating to the land as listed in schedule 4 of the EP&A Regulation which identifies bush fire prone land (or any part of the land) as being a relevant matter that should be notified within the section 149 Planning Certificate.

**2.5 Major Projects**

Part 3A of the EP&A Act commenced on 1 August 2005 and provides an assessment process for development declared to be a Major Project under a SEPP or by the Minister for Planning.

Part 3A provides for an integrated assessment of major development taking into account bush fire risk. Proponents should consult with PBP when selecting sites for development and undertaking environmental assessments.

## 2.6 Construction Provisions: The BCA and AS 3959

The Building Code of Australia (BCA) is a performance based code which derives its statutory power through the EP&A Act and EP&A Regulation, in NSW. The EP&A Regulation requires a Certifying Authority, prior to issuing a construction certificate or complying development certificate, to be satisfied that the relevant requirements of the BCA will be met.

The BCA contains both performance requirements and deemed-to-satisfy provisions relating to the construction of buildings in bush fire prone areas. These provisions apply to Class 1, 2, 3, 4 and SFPP buildings that are proposed for construction in designated bush fire prone areas.

The construction requirements of AS 3959 - 1999 *Construction of Buildings in Bush Fire-prone Areas* are accepted by PBP as the deemed-to-satisfy construction standard for buildings in designated bush fire prone areas.

In addition, the BCA has been amended with a NSW specific variation to include Appendix 3 which contains the site assessment methodology and replaces Section 2 of the AS 3959 - 1999 when determining bush fire attack and the construction levels required to comply with the BCA on BPA.

For Residential/Rural Residential Subdivision, the APZ distances are designed to meet the deemed-to-satisfy arrangement under the BCA (by reference to AS 3959). DA stage applicants must determine the relevant construction level, without necessarily providing full construction detail for future dwellings on the 'interface' allotments. This commits certifying authorities to that level of construction. Proposed changes to the level of construction or BCA alternative solutions may require DA modification. The path for infill housing is similar, with Level 3 construction (as a minimum) or other alternative solutions providing bush fire protection at DA construction certificate (CC) stage.

For sites proposed for SFPPs, APZs are based on a derived radiant heat exposure (10 kW/m<sup>2</sup>) to an emergency worker, which corresponds to Level 1 construction standards (AS 3959).

Similarly, PBP uses AS 3959 to cover Class 4 (BCA) buildings i.e. caretakers accommodation. Class 10a buildings forming an addition or extension to a Class 1 - 4 building are treated the same as a Class 1 - 4 building. For other BCA Classes, bush fire specific construction standards are not addressed (i.e. Classes 5-8 some Class 9 and 10b).

## 2.7 Rural Fires Act, 1997

### (a) Bush Fire Safety Authorities (section 100B of the RF Act)

Government agencies may be required to consider the environmental or physical constraints to development through the granting of licences, permits or other approvals. These agencies are referred to as approving authorities and their licences, permits or approvals are integrated through section 91 of the EP&A Act.

An example is the requirement under Section 100B of the RF Act for the Commissioner of the RFS to issue a bush fire safety authority for applications for residential or rural - residential subdivisions and any application for SFPP.

Under the integrated development process, the approval authority (in this case the Commissioner of the RFS) is required to provide "general terms" of agreement to the consent authority. Where an approving authority refuses to grant an approval, the consent authority cannot issue the consent and the development cannot proceed. In general, the approving authority has 40 days upon receipt of the development application and supporting documents in which to determine the matter.

A refusal is subject to appeal to the Land and Environment Court.

Section 100B provides that where a BFSA is required for subdivision, or an SFPP, the development cannot be considered 'complying development' under any environmental planning instrument in a bush fire prone area.

### (b) Information required for a Bush Fire Safety Authority

To support an application for a bush fire safety authority, an applicant is required to submit a bush fire assessment in accordance with clause 46 of the RF Regulation.

The information to be contained in such a report is listed in Appendix 4.

The consent authority will determine the acceptability of the environmental impact of a proposed development in terms of environmental significance, threatened species and Aboriginal heritage.

In considering the issues of threatened species and Aboriginal heritage, the RFS uses this information to determine any site constraints or the rationale for performance-based solutions.

### (c) Section 63 of the RF Act

Section 63 of the RF Act places a 'duty of care' on all land managers/owners to prevent a fire spreading on or from their land. This duty is related to future developments in that the provision and maintenance of appropriate setbacks and landscaping must be addressed when developing land.

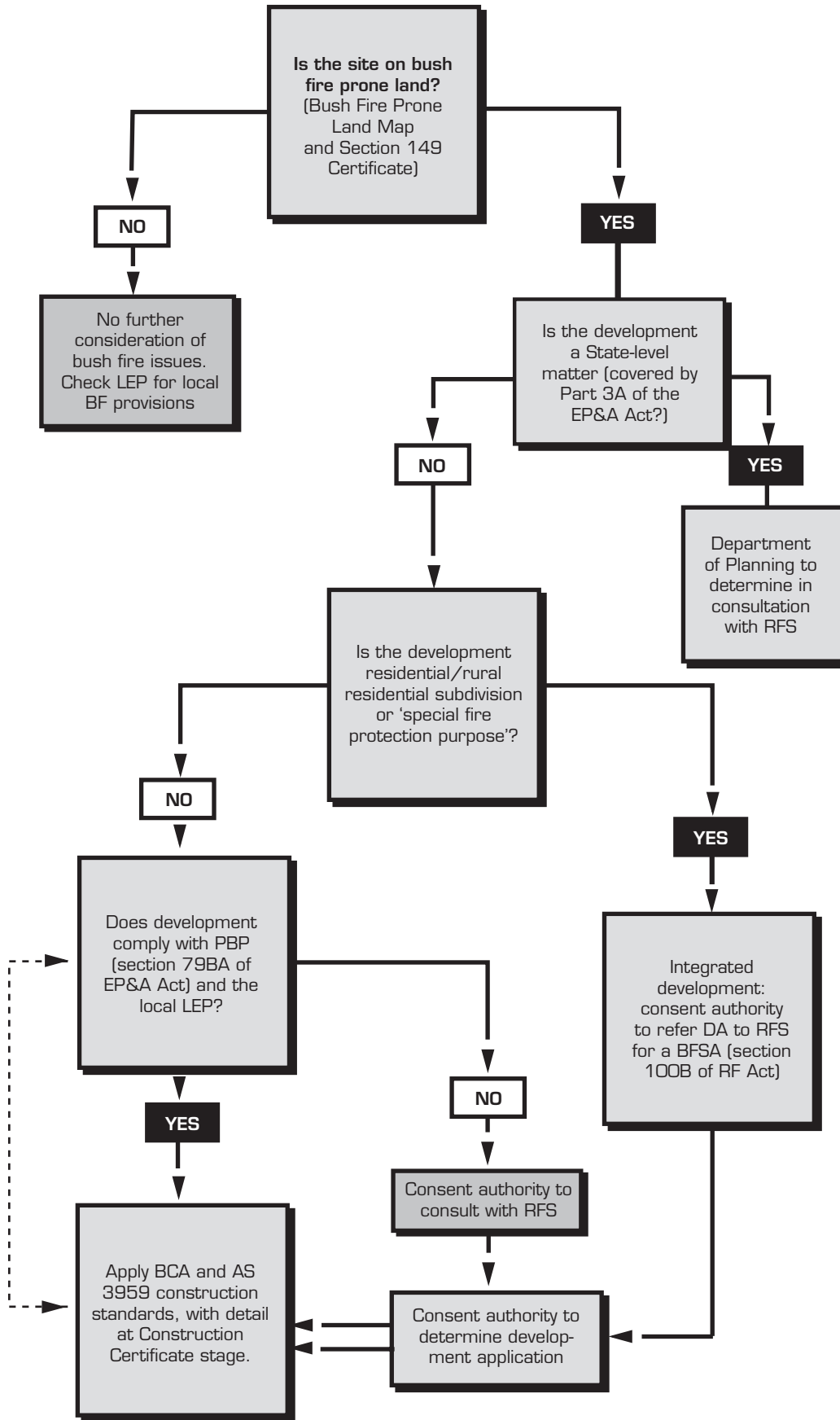

Figure 2.1 Development Control Process for Developments in Bush Fire Prone Areas

## 3.1 Bush Fire Protection Measures

In general terms, an acceptable level of protection from bush fires is achieved through a combination of strategies which:

- Control the types of development permissible in bush fire prone areas (see Box);
- Minimise the impact of radiant heat and direct flame contact by separating the development from the bush fire hazard;
- Reduce the rate of heat output (intensity) of a bush fire close to a development through control of fuel levels;
- Minimise the vulnerability of buildings to ignition from radiation and ember attack;
- Enable relatively safe access for the public and facilitate fire-fighting operations;
- Provide adequate water supplies for bush fire suppression operations;
- Implement community education programs, focusing on property preparedness, including emergency planning and property maintenance requirements; and
- Facilitate the maintenance of APZs, fire trails, access for firefighting and on-site equipment for fire suppression.



Community education programs



Access for firefighting should be safe.

### Controlling Development Types.

*Developments which should not be permitted on bush fire grounds, including those that may start bush fires or are a potential hazard to adjacent areas or to fire fighters if they are impacted upon by a bush fire:*

- **Power generating works**
- **Sawmills**
- **Junk yards**
- **Liquid fuel depots**
- **Offensive and hazardous industries**
- **Chemical industries**
- **Service stations**
- **Ammunition storage/manufacture**
- **Fire works manufacture/storage**

In a development assessment context, there are six key Bush Fire Protection Measures (BPMs):

- a) The provision of clear separation of buildings and bush fire hazards, in the form of fuel-reduced APZ (and their subsets, inner and outer protection areas and defensible space);
- b) Construction standards and design;
- c) Appropriate access standards for residents, fire fighters, emergency service workers and those involved in evacuation;
- d) Adequate water supply and pressure;
- e) Emergency management arrangements for fire protection and/or evacuation; and
- f) Suitable landscaping, to limit fire spreading to a building.



Reduce the vulnerability of buildings to ignition from radiation and ember attack

The BPMs are described as follows:

**(a) Asset protection zones and defensible space**

An APZ is a buffer zone between a bush fire hazard and buildings, which is managed progressively to minimise fuel loads and reduce potential radiant heat levels, flame, ember and smoke attack. The appropriate APZ is based on vegetation type, slope and levels of construction (and for SFPPs the nature of development). The APZ can include **perimeter roads** in new subdivisions. For other development, existing roads, other buildings or managed properties can be considered as part of the APZ.

For forest and woodland vegetation, the APZ consists of two areas:

- **Inner Protection Area**, closest to buildings, incorporating the defensible space and for managing heat intensities at the building surface; and
- **Outer Protection Area**, for reducing the potential length of flames by slowing the rate of spread, filtering embers and suppressing the crown fire.

**Appendix 2** provides the required methodology for calculating the APZ and is based on vegetation type, slope and assumed construction levels (see below – bush fire protection measures in combination).

A defensible space, a subset of the APZ, is required as a workable area in which firefighters, emergency services personnel, residents and others can undertake property protection after the passage of a bush fire.

For **Special Fire Protection Purposes**, such a workable and defensible space is required for firefighters and other emergency services personnel to operate under critical conditions of radiant heat, smoke and embers, while assisting or evacuating occupants or other vulnerable members of the community with restricted mobility due to age, disability or other incapacity.

**b) Construction standards and design**

For development on bush fire prone land preliminary consideration of construction levels is necessary at DA stage:

- to ensure reasonable building requirements (and costs) following residential and rural/residential subdivision. Deemed to satisfy BCA construction standards should be applied in accordance with Appendix 3;
- as assumptions (for performance requirements) underpinning the APZ in Appendix 2 are met; and
- as a potential argument, by applicants, to minimize APZ.

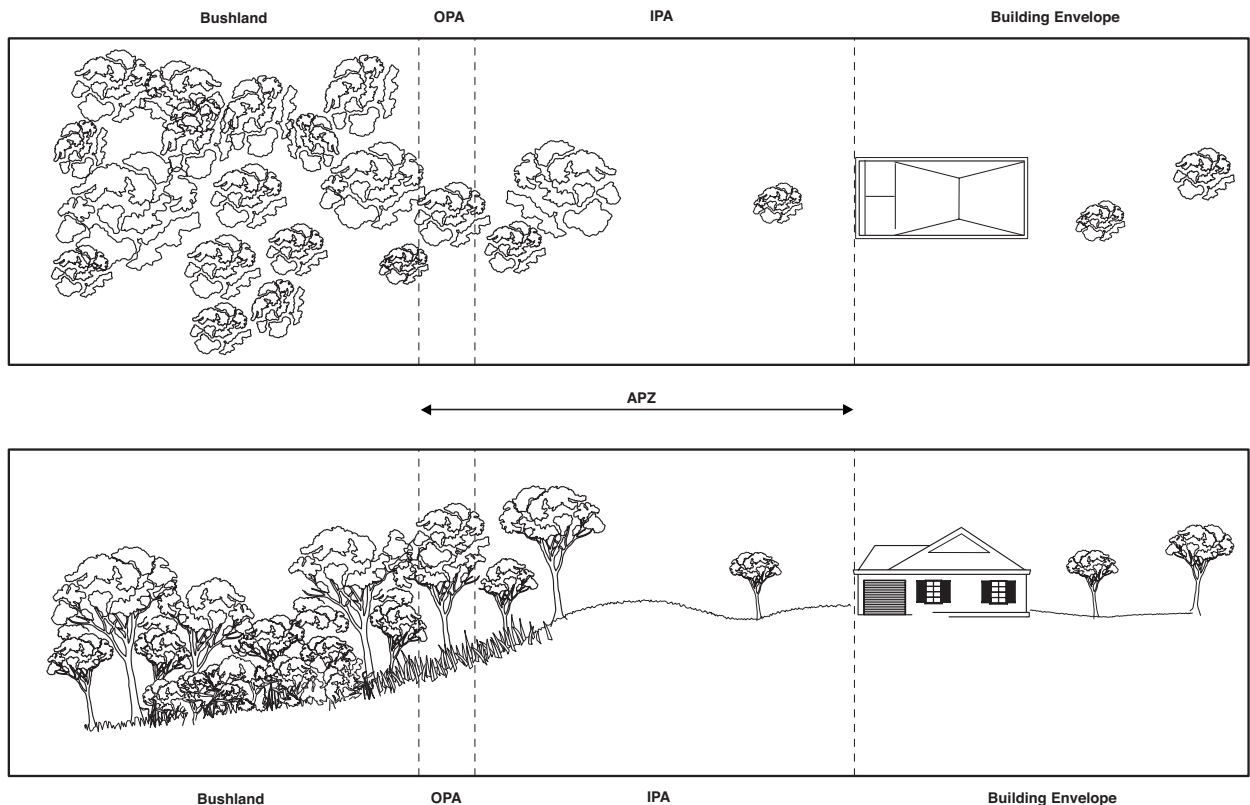

Figure 3.1 shows the APZ, IPA and OPA graphically.

In infill situations, where flame contact is also possible, design considerations need to be addressed to ensure some types of building elements (e.g. windows) are protected.

**(c) Access standards (public roads, private access and fire trails)**

For new subdivisions and large scale SFPPs, design of public and property access roads should enable safe access, egress and defensible space for emergency services. Fire trails enable access for management of APZs. These principles also apply for other developments but greater emphasis on landscaping, construction and other BPMs may be necessary.



*Fire fighting vehicles need access to the urban bushland interface.*

**(d) Water Supply and Utility Services**

Adequate supply of water is essential for fire fighting purposes when considering all forms of development. In addition, gas and electricity should be located so as not to contribute to the risk of fire or impede the fire fighting effort.



*Services can be cut during a bush fire*

**(e) Emergency management arrangements**

Emergency and evacuation arrangements e.g. procedures, routines and consideration of safe havens, are of particular relevance to SFPPs.

**(f) Landscaping**

In considering all DAs, the type, location and ongoing maintenance of landscaping, within the APZ is a necessary bush fire protection measure. Appendix 5 provides advice.



*Maintaining the property and landscaping is of critical importance*

### 3.2 The bush fire protection measures (BPMs) in combination

A significant part of the State is classified as bush fire prone land and local circumstances vary widely as do potential land uses. PBP recognises this and promotes detailed site analysis and the application of a combination of bush fire protection measures to achieve an acceptable outcome.

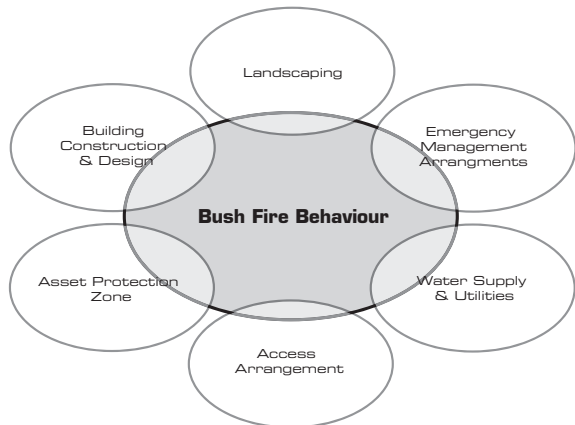

Figure 3.2 Bush Fire Protection Measures in combination

Appropriate combinations not only depend upon geographic location and site circumstances but also on the nature of the proposed use. The legal framework (see Chapter 2) distinguishes between:

- Residential and rural-residential subdivision;
- Special Fire Protection Purposes; and
- Infill (and other developments).

The introduction to each section of Chapter 4 provides specific objectives relating to each of these development types.

The starting point is the provision of an asset protection zone. A fuel-reduced, physical separation between buildings and bush fire hazards is the key element in the suite of measures. A wealth of detailed scientific research on bush fire behaviour under a range of location, weather, vegetation and slope conditions has demonstrated the significance of reduced fuel loads and distance in limiting bush fire threat (from ember attack through to direct flame contact). This detail is embodied in the provisions of Appendix 2.

APZ requirements are based on keeping radiant heat levels at buildings (other than SFPPs) below 29kW/m<sup>2</sup>. For SFPPs, the type of occupants requires a different approach. In order for emergency services to operate in support of those occupants with limited mobility, the requirements for APZs are higher, with 10kW/m<sup>2</sup> as the target exposure on all sides of the building where there are access points. The APZ tables are based

on this requirement. This is to allow an area for firefighters to defend the property and allow access to and from the building.

A subset of the APZ and an essential component of infill developments is the provision of a defendable space. This is a space to ensure the safety of fire fighters and residents following the passage of a fire front.

Once the APZ standard is achieved, required construction standards can then be met in accordance with Appendix 3. The provision, design and location of other measures can then be detailed.

The acceptable solutions in this document, which incorporate the detailed methodology and Appendices, acknowledge that the measures work in combination to achieve good bush fire protection, while not needlessly reducing lot yields/site coverage or threatening environmental sustainability.

For instance:

- for residential subdivision, required APZ is calculated for level 3 construction (at the interface), thus minimising APZ, maximizing lot yield and minimising habitat destruction. To pursue further reductions in APZ, alternate solutions for building construction and use of other elements could be argued (subject to evidence noted above) that meet the performance criteria; and
- for SFPPs, where the characteristics of occupants require special care (e.g. elderly or school children), construction standards are less significant and the required APZ is crucial for emergency services to operate in support of those occupants. It is possible, however, that some SFPPs, such as tourist accommodation (e.g. eco-tourism or local B&Bs) are occupied by able-bodied persons and that evacuation plans or refuge are appropriate alternative options.

In relation to detailed building design and consideration of ingress and egress the “measures in combination” approach also applies. For instance, facing the building away from a hazard can enable a variation in the defendable space and construction standards.

In summary, the provision of an APZ, clearly separating buildings from hazards, and reducing fuel loads, is the first step. In exceptional circumstances, trading off APZ for increased construction standards and/or evacuation measures can be proposed, but how these will meet the objectives of PBP and the intent/performance criteria of each element must be clearly demonstrated.

### 3.3 Exceptional circumstances for APZs

Reduced APZs and the use of adjoining lands for meeting APZ requirements will only be permitted in exceptional circumstances based on the merits of the particular development.

It is not possible to be definitive about the full range of such circumstances. However, through previous Land and Environment Court cases and experience it is possible to give examples of the type of situations that could be considered exceptional.

Consideration is on a case-by-case basis and the applicant should provide clear evidence that, because of the circumstances of the case e.g. location or type of use, strict prescriptive compliance is unreasonable and unnecessary.

For exceptional circumstances to apply, the following principles should be demonstrated:

- the existing form of development will obtain a better bush fire risk outcome than if the development did not proceed (eg through increased construction standards);
- the building line should be no closer to the hazard than neighbouring properties;
- the extensions should be no closer to the hazard than the existing building footprint;
- an upgrade of existing facilities may be required; and
- the proposal is an infill arrangement and site constraints do not allow APZ requirements to be met.

An increase in residential densities is not, by itself, considered an exceptional circumstance.

#### (a) Reduced APZ

Where the required APZ cannot be provided, or a reduction is proposed, the applicant must:

- provide for a defensible space;
- demonstrate that the intent and performance criteria for the APZ (for the type of development in Chapter 4) will be satisfied; and
- demonstrate that other measures, in combination, will meet the relevant radiant heat levels specified in the performance criteria for APZs and will achieve the aim and objectives of PBP (see section 1.1).

Clearly, it is not acceptable to neglect bush fire measures at subdivision and LEP stage with the aim of solely relying on construction standards to provide protection from bush fires. APZs, designed to separate the hazard from the development, and adequate access provisions must be incorporated at all stages of the development.

For existing subdivisions, where bush fire protection measures were not incorporated at

the development application stage, it may not be possible to achieve an APZ of the required width between the building site and the bush fire hazard. Development in these areas therefore poses some difficulties and higher levels of construction standards may be needed.

There may be situations where a combination of poor access, rugged topography, remote location and an inability to provide an adequate APZ would pose an unacceptable bush fire risk, even if the building was constructed in accordance with the strictest construction standards. In these cases, there is a strong argument for refusal of the development application. An essential requirement is the provision of a defensible space from any boundary that interfaces with the bushland.

#### (b) APZs on adjoining lands

Neither the RFS nor a council has the power to impose an APZ on an adjoining landowner. It is therefore the developer's responsibility to negotiate with adjoining land owner/s as part of the development application process. Details of the proposed easement and the adjoining owners consent should be submitted with the development application.

The DA must demonstrate that exceptional circumstances apply to the land to be developed prior to approval for the establishment of an easement. The requirement for an easement will then be included in the conditions of approval for the issuing of a BFS/development consent.

The owner/occupier of the land who has benefited from the easement shall be responsible for maintaining the APZ.

Where an APZ easement has been established to the benefit of a community title, it shall be maintained in accordance with a plan of management (Part 5 of the Management Statement) for the community titled land.

Easements should not be considered where the adjoining land is used for a public purpose, where vegetation management is not likely or cannot be legally granted (eg National Park, council bushland reserve, SEPP 14 or SEPP 26, critical habitat). Existing easements for power and other services will be considered on their merits.

#### Examples of acceptable exceptional circumstances

The following are considered to be exceptional circumstances that may apply to a development application for an APZ to be located on adjoining land in bush fire prone areas.

- Where it can be demonstrated that there is a strong likelihood of the adjoining land being developed for future residential or other compatible purposes (eg staged development or Urban Development Program or Strategies with supporting development control plans).
- Where a development was approved prior to 1 August 2002 and the applicant is only proposing alterations and/or additions to existing buildings and the existing APZ does not comply with current APZ requirements. The alterations/additions should lead to increased construction standards up to and beyond BCA (AS 3959) Level 3 construction.
- Where easements are also required on adjoining land for the purposes of providing access for utilities, right of way, as fire trails, and drainage. These are to be kept clear of free standing vegetation. In such circumstances, the proponent will need to obtain written confirmation from the relevant authority that the easement will continue to be maintained in a suitable manner.
- Where the proposal is considered 'infill development' for a single residential building and existing residential areas will also (or currently) benefit from improved APZs on the same adjoining land holding.

In all cases, the adjoining owner's consent is required to be lodged with the development application for an easement.

#### (c) Location on Slopes over 18 Degrees

An APZ should not be located on land steeper than 18 degrees as:

- some management practices are impossible and all become difficult;
- the environmental consequences of ground clearing (destabilization of the slope resulting

in landslip, slump, erosion or landslide) may not be acceptable; and

- the canopy fuels in forests and woodlands are more readily available to a fire, significantly reducing the advantage of having an APZ.

Developments abutting such slopes should be located so that both the APZ and the development are not located on wooded slopes steeper than 18 degrees. Where slopes steeper than 18 degrees are predominantly grassland with sparse trees, a distance of 20 metres should be provided from the edge of the sloping land.

Where it can be demonstrated that these issues can be effectively managed, APZs on steeper slopes will be considered as an exceptional circumstance.

APZ tables in Appendix 2 are provided for acceptable solutions with slopes up to 18 degrees. Effective slopes in excess of 18 degrees will require a detailed performance assessment.

#### (d) APZs in Split Zones

In some cases, a development may be proposed on land with a split zoning (e.g. Rural Residential/ Environmental Protection). Bush fire protection measures may not necessarily be compatible with one of the zones. It should not be assumed that an APZ can extend into an adjoining non compatible zone and the suitability of this should be checked with the local council.

Where environmental values such as endangered ecological communities are to be cleared, the proposal will need to be carefully considered in the light of the impact of the requirements for asset protection zones on these values.

As with easements, a suitable covenant may be proposed as an exceptional circumstance which protects environmental values and provides suitable bush fire protection measures.



## 4.1 Planning controls for residential and rural residential subdivisions

### 4.1.1 What is subdivision?

The term “subdivision” is defined in the EP&A Act (see Dictionary, page 73).

Subdivision of land for a residential or rural-residential purpose is the subdivision of any land on which the zoning permits the construction of a Class 1, 2, 3 or 4 building under the BCA. For example, many industrial and commercial subdivisions permit a residential house (caretaker’s residence) to be constructed. Such subdivisions are considered residential and should be assessed.

A boundary adjustment is also considered subdivision.

The consolidation of two or more lots into one is not defined as subdivision and is not captured under section 100B of the RF Act as requiring a BFSA.

#### (a) Residential subdivision

Residential subdivision can consist of large to medium scale “releases” of land for extension of urban areas or smaller scale “local” subdivision and is usually associated with single dwelling houses - though dual occupancy and multi-unit developments may be permissible. Development consent is required from the council for subdivision and a BFSA is required from RFS. Development consent, or a Complying Development Certificate, is then

required for individual dwellings.

In new subdivisions an appropriate combination of BPMs, especially an APZ, should be provided.

#### (b) Rural-Residential Developments

Rural-residential developments include blocks often associated with lifestyle choices rather than focusing on some form of primary production. Where agricultural pursuits are undertaken they are considered secondary to the residential component of the use of the land.

Consideration should be given, where practical, to grouping of rural-residential buildings into clusters which allow for the establishment of APZs around a group of dwellings rather than having to ensure individual protection for a large number of scattered dwellings. The clustering of dwellings provides for better protection with reduced vegetation clearance and hence less environmental impact.

#### (c) Isolated Rural Developments

Subdivision for the creation of isolated rural developments, particularly in rugged, heavily timbered country, poses additional problems in the provision of adequate levels of protection from bush fires. Where developments are located in these areas, occupants and firefighters may have to travel large distances through bush fire prone vegetation. In addition, the isolation means that, if a fire impacts on the development, occupants may also be a long way from firefighting assistance.



*Perimeter roads should be the normal arrangement for urban areas and not perimeter fire trails.*

The major issues for isolated rural developments arise from the need to protect firefighters as well as residents in less accessible areas. As a result greater emphasis is placed on:

- the provision of safe access/egress to the property so occupants leaving, and firefighters/rescuers accessing the property, can do so in relative safety;
- the provision of adequate APZs to create an area where occupants and firefighters remaining on site will have a good chance of survival; and
- water supplies and fire protection systems such as spray systems. In such cases dedicated water supplies may exceed standard requirements.

To achieve the required level of protection, dedicated static water supplies will need to be extended beyond the specification recommended in this document. This requirement will need to be determined based on the extent of the hazard faced and the isolation and access arrangements of the development.

Travel distances of 200 metres or more are particularly problematic in that it is difficult to

traverse with dense smoke and reduced vision as well as the increased chance of being isolated by the advancing fire. Trees close to the access track become obstacles in the hazy environment. For these reasons, where access is greater than 200 metres from a main road or refuge suitable for occupants and firefighters, a second access arrangement is required which provides alternative access in a different direction from the main access.

#### (d) Detailed subdivision design

The subdivision stage of land development provides an opportunity for early consideration of siting and access and for the incorporation of a preferred combination of bush fire protection measures.

PBP promotes detailed site analysis to minimise the potential for bush fire attack. Wide variation across the state, in terms of local climatic conditions is acknowledged, as well as local site characteristics such as slope and vegetation types. These site characteristics are embodied in the APZ and construction level tables set out in Appendices 2 and 3.

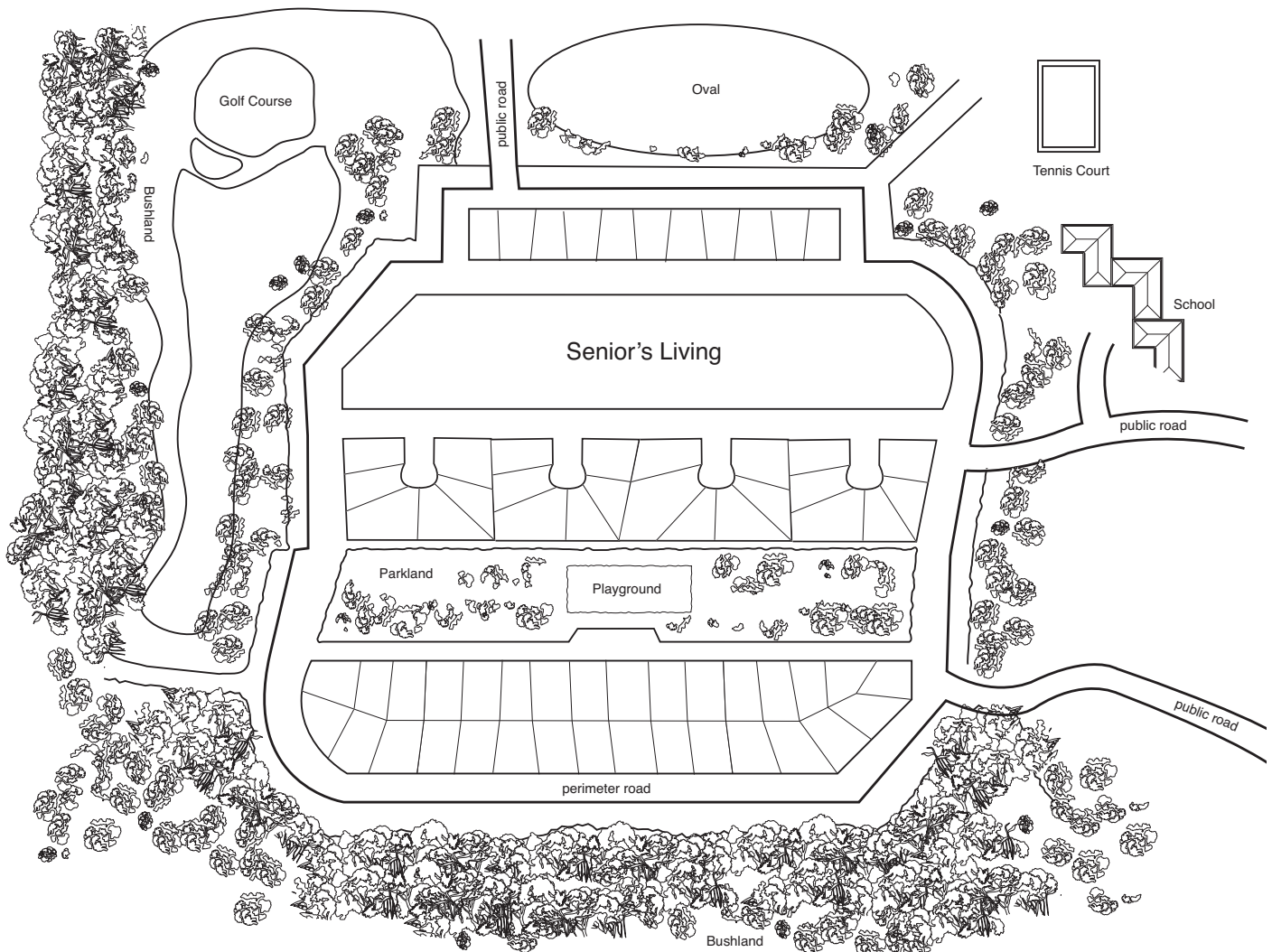

Figure 4.1 Detailed site analysis for residential subdivision

### 4.1.2 Specific Objectives for Subdivisions

The specific objectives for residential and rural residential subdivision are to:

- minimise perimeters of the subdivision exposed to the bush fire hazard. Hourglass shapes, which maximise perimeters and create bottlenecks, should be avoided.
- minimise bushland corridors that permit the passage of bush fire
- provide for the siting of future dwellings away from ridge-tops and steep slopes - particularly up-slopes, within saddles and narrow ridge crests.
- ensure that separation distances (APZ) between a bush fire hazard and future dwellings enable conformity with the deemed-to-satisfy requirements of the BCA. In a staged development, the APZ may be absorbed by future stages.

- provide and locate, where the scale of development permits, open space and public recreation areas as accessible public refuge areas or buffers (APZs)
- ensure the ongoing maintenance of asset protection zones
- provide clear and ready access from all properties to the public road system for residents and emergency services
- ensure the provision of and adequate supply of water and other services to facilitate effective firefighting.

As indicated in Chapter 3, an **appropriate combination of BPMs, commencing with an APZ**, is to be provided to satisfy the above objectives (and the general aim and objectives of PBP). In addition, the performance criteria that follows (for each measure) must be satisfied.

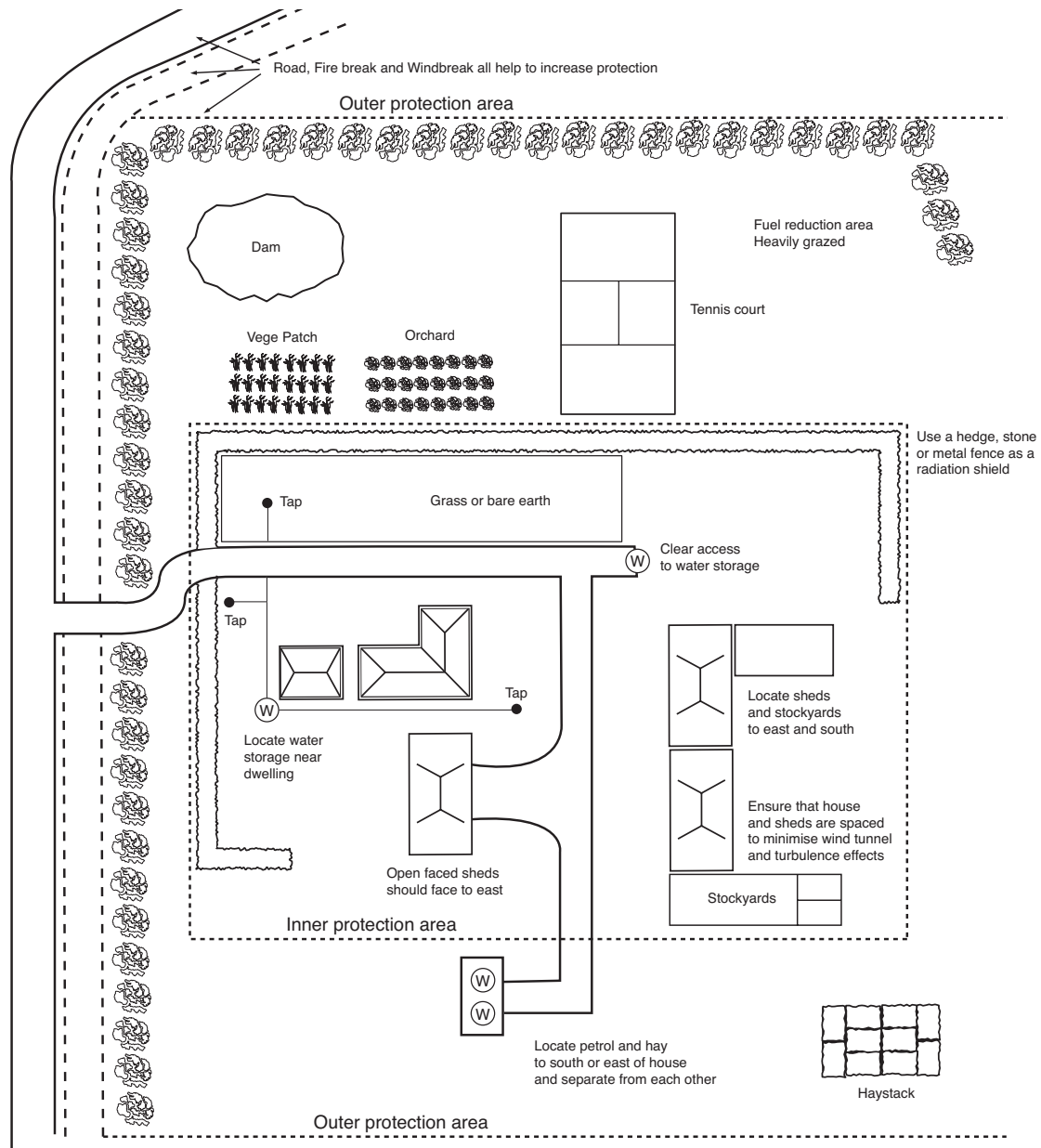

Figure 4.2 Bush fire protection measures for rural property

### 4.1.3 Standards for Bush Fire Protection Measures for Residential and Rural Residential Subdivisions

#### Asset Protection Zones

**Intent of measures: to provide sufficient space and maintain reduced fuel loads, so as to ensure radiant heat levels at buildings are below critical limits and to prevent direct flame contact with a building.**

#### Background

The APZ ensures that buildings are separated from the hazard and is designed to minimize the presence of fuels, which could become involved in a fire. Therefore, the impact of direct flame contact, radiant heat and ember attack on the development is minimised.

The APZ standards are designed to ensure that future buildings can conform to the deemed-to-satisfy arrangements under the BCA. (i.e. the provisions for Level 3 construction of AS 3959 and this document).

Residential subdivisions should not offset bush fire protection measures to neighbouring land. Bush fire protection measures that are essential to a development should occur on the site of the proposed development unless exceptional circumstances apply.

A proponent should not diminish the ecological integrity of adjoining bushland, and APZs should be designed to minimise the impacts on any environmental features in the landscape.

The RFS will generally not approve the subdivision of land for a residential or rural-residential subdivision purpose when the building footprint is unable to meet the necessary setbacks for an asset protection zone.

Where a bush fire hazard exists **on or adjacent to** a development site, an APZ is to be established on the hazard side of the development in accordance with Appendix 2 and as indicated in Figure 4.3.

As a condition of development consent, the consent authority is required to ensure that a mechanism is established for the maintenance of APZs over the life of the development. Options include a levy on property owners to fund ongoing maintenance, body corporate or community title schemes and positive covenants (under s.88B of the *Conveyancing Act 1919*) at the development stage.

#### Components of an Asset Protection Zone

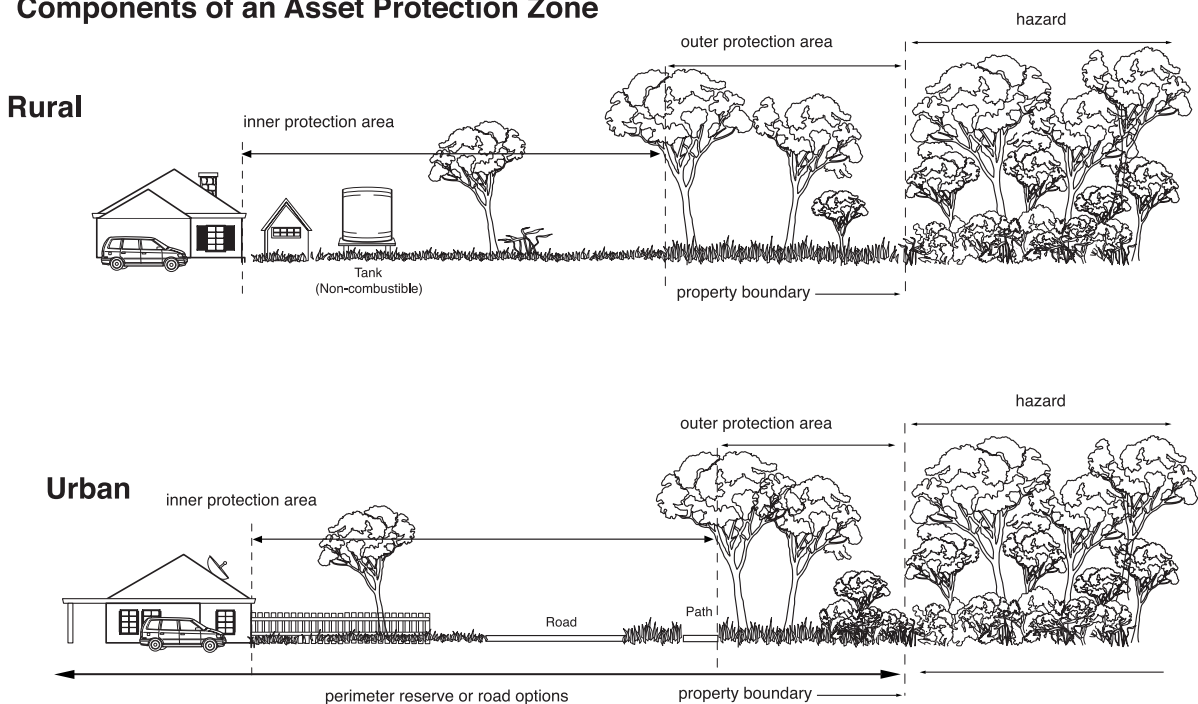

Figure 4.3 APZs and progressive reduction in fuel loads

Performance Criteria	Acceptable solutions
<p>The intent may be achieved where:</p>	
<ul style="list-style-type: none"> <li>radiant heat levels at any point on a proposed building will not exceed 29 kW/m<sup>2</sup></li> </ul>	<ul style="list-style-type: none"> <li>an APZ is provided in accordance with the relevant tables/figures in Appendix 2 of this document</li> <li>the APZ is wholly within the boundaries of the development site. Exceptional circumstances may apply (see section 3.3)</li> </ul>
<ul style="list-style-type: none"> <li>APZs are managed and maintained to prevent the spread of a fire towards the building.</li> </ul>	<ul style="list-style-type: none"> <li>in accordance with the requirements of Standards for Asset Protection Zones (RFS, 2005)</li> </ul> <p><i>Note: A Monitoring and Fuel Management Program should be required as a condition of development consent.</i></p>
<ul style="list-style-type: none"> <li>APZ maintenance is practical, soil stability is not compromised and the potential for crown fires is negated</li> </ul>	<ul style="list-style-type: none"> <li>the APZ is located on lands with a slope less than 18 degrees.</li> </ul>



*Some past planning practices have provided no effective protection to life and property in the event of a severe bush fire.*

## Access (1) – Public Roads

**Intent of measures: to provide safe operational access to structures and water supply for emergency services, while residents are seeking to evacuate from an area.**

### Background

Public roads include the perimeter road and the internal road system of any urban subdivision as well as public roads in rural-residential subdivisions.

A **perimeter road** is the preferred option to separate bushland from urban areas. Fire trails will only be considered acceptable in exceptional circumstances. This is based on the difficulties and costs associated with maintaining fire trails on private land. A perimeter fire trail cannot be imposed on the adjoining land and should not cross a number of residential allotments.

The perimeter road forms part of the APZ and is required to provide a separation between the building and the boundary of the bush fire hazard.

The purpose of the public road system is to:

- provide firefighters with easier access to structures, allowing more efficient use of firefighting resources;
- provide a safe retreat for firefighters; and
- provide a clear control line from which to conduct hazard reduction or back burning operations.

Roads should provide sufficient width to allow firefighting vehicle crews to work with firefighting equipment about the vehicle.

Where staged development occurs or development operates under an approved Masterplan, the RFS will consider temporary perimeter roading subject to availability of reticulated water supply.

Table 4.1 provides the minimum widths for public roads that are not perimeter roads for the safe access of fire fighting vehicles in urban areas.

Curve radius (inside edge) (metres)	Swept Path (metres width)	Single lane (metres width)	Two way (metres width)
<40	3.5	4.5	8.0
40-69	3.0	3.9	7.5
70-100	2.7	3.6	6.9
>100	2.5	3.5	6.5

Source: AS 2890.2 – 2002.

Table 4.1 – Road widths for Category 1 Tanker (Medium Rigid Vehicle)

Figure 4.4 provides the dimensions for the curvature of roads (inner and outer turning circles) to be used for access roads (both public and private) and fire trails.

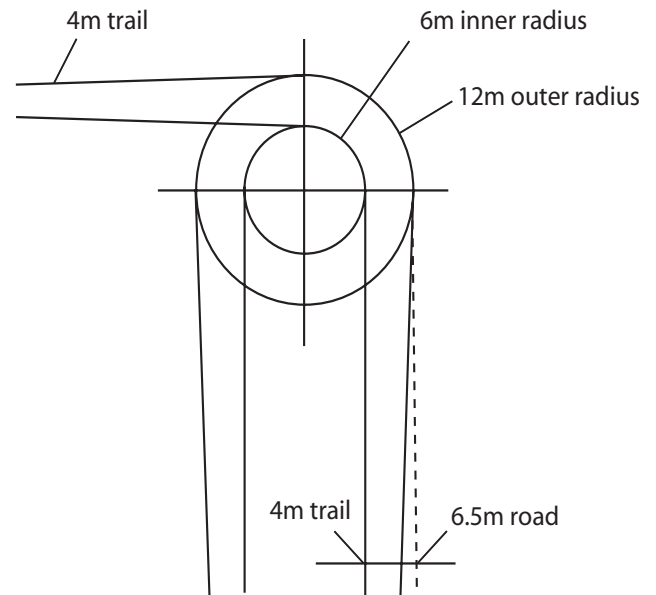

Figure 4.4 Dimensions for inner and outer turning circle radius for (public and private access) roads and fire trails.



Examples of public road access arrangements that do not facilitate bush fire fighting.

Performance Criteria	Acceptable solutions
The intent may be achieved where:	
<ul style="list-style-type: none"> <li>firefighters are provided with safe all weather access to structures (thus allowing more efficient use of firefighting resources)</li> </ul>	<ul style="list-style-type: none"> <li>public roads are two-wheel drive, all weather roads.</li> </ul>
<ul style="list-style-type: none"> <li>public road widths and design that allow safe access for firefighters while residents are evacuating an area.</li> </ul>	<ul style="list-style-type: none"> <li>urban perimeter roads are two-way, that is, at least two traffic lane widths (carriageway 8 metres minimum kerb to kerb), allowing traffic to pass in opposite directions. Non perimeter roads comply with Table 4.1 – Road widths for Category 1 Tanker (Medium Rigid Vehicle).</li> <li>the perimeter road is linked to the internal road system at an interval of no greater than 500 metres in urban areas.</li> <li>traffic management devices are constructed to facilitate access by emergency services vehicles.</li> <li>public roads have a cross fall not exceeding 3 degrees.</li> <li>all roads are through roads. Dead end roads are not recommended, but if unavoidable, dead ends are not more than 200 metres in length, incorporate a minimum 12 metres outer radius turning circle, and are clearly sign posted as a dead end and direct traffic away from the hazard.</li> <li>curves of roads (other than perimeter roads) are a minimum inner radius of six metres and minimal in number, to allow for rapid access and egress.</li> <li>the minimum distance between inner and outer curves is six metres.</li> <li>maximum grades for sealed roads do not exceed 15 degrees and an average grade of not more than 10 degrees or other gradient specified by road design standards, whichever is the lesser gradient.</li> <li>there is a minimum vertical clearance to a height of four metres above the road at all times.</li> </ul>
<ul style="list-style-type: none"> <li>the capacity of road surfaces and bridges is sufficient to carry fully loaded firefighting vehicles.</li> </ul>	<ul style="list-style-type: none"> <li>the capacity of road surfaces and bridges is sufficient to carry fully loaded firefighting vehicles (approximately 15 tonnes for areas with reticulated water, 28 tonnes or 9 tonnes per axle for all other areas). Bridges clearly indicate load rating.</li> </ul>
<ul style="list-style-type: none"> <li>roads that are clearly sign-posted (with easily distinguishable names) and buildings/properties that are clearly numbered.</li> </ul>	<ul style="list-style-type: none"> <li>public roads greater than 6.5 metres wide to locate hydrants outside of parking reserves to ensure accessibility to reticulated water for fire suppression.</li> <li>public roads between 6.5 metres and 8 metres wide are No Parking on one side with the services (hydrants) located on this side to ensure accessibility to reticulated water for fire suppression.</li> </ul>
<ul style="list-style-type: none"> <li>there is clear access to reticulated water supply</li> </ul>	<ul style="list-style-type: none"> <li>public roads up to 6.5 metres wide provide parking within parking bays and locate services outside of the parking bays to ensure accessibility to reticulated water for fire suppression.</li> <li>one way only public access roads are no less than 3.5 metres wide and provide parking within parking bays and locate services outside of the parking bays to ensure accessibility to reticulated water for fire suppression.</li> </ul>
<ul style="list-style-type: none"> <li>parking does not obstruct the minimum paved width</li> </ul>	<ul style="list-style-type: none"> <li>parking bays are a minimum of 2.6 metres wide from kerb edge to road pavement. No services or hydrants are located within the parking bays.</li> <li>public roads directly interfacing the bush fire hazard vegetation provide roll top kerbing to the hazard side of the road.</li> </ul>

## Access (2) – Property Access

**Intent of measures:** to provide safe access to/from the public road system for firefighters providing property protection during a bush fire and for occupants faced with evacuation.

### Background

The public road system in a bush fire prone area should provide alternative access or egress for firefighters and residents during a bush fire emergency if part of the road system is cut by fire.

Property access is access from a public road system onto private land and access to the habitable building by fire fighters.

A distinction is drawn between rural private access roads and those in urban areas.

In rural areas, in particular isolated rural properties, operational difficulties can be experienced in accessing buildings. Examples include water crossings, roads being cut by fire and hazardous conditions. As a result, the location

and standards of property access roads should be carefully considered.

Where property access is required across other land, the owner's consent to legally binding arrangements covering access and ongoing maintenance are required prior to lodging a development application.

Short property access roads are preferable to long ones for the safety of evacuating residents and emergency service personnel, and therefore it is preferable to site dwellings as close as possible to public through roads.

By comparison, urban areas have an existing infrastructure and requirements are generally less of a problem. In addition, it is acknowledged that fire appliances will generally operate from the public road system.

Where a property access road provides internal access arrangements for community title or similar subdivision arrangements, the provisions of 4.2.7 in relation to internal roads also apply.

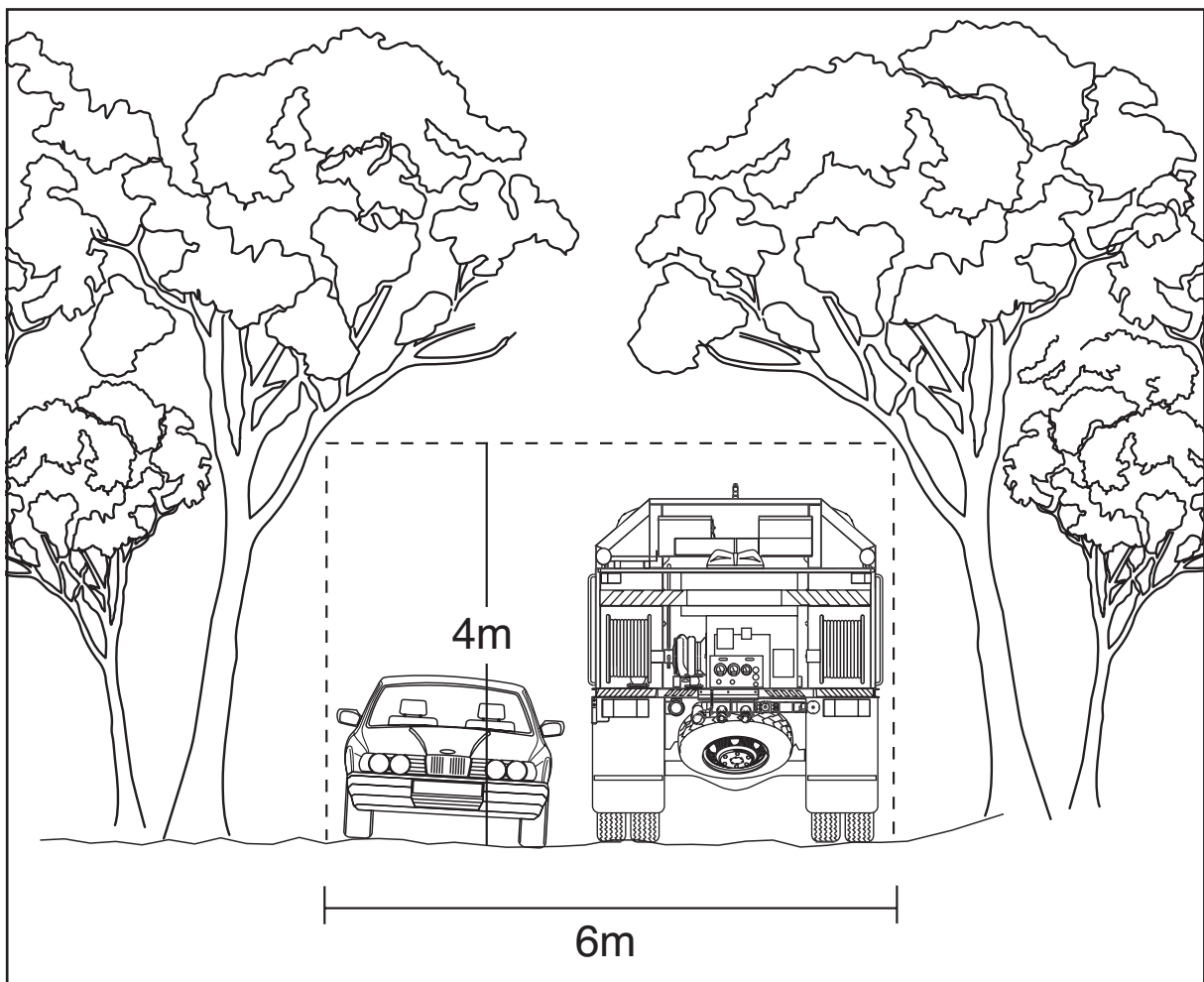

Figure 4.5 Property access road requirements (rural areas)

Performance Criteria	Acceptable solutions
<b>The intent may be achieved where:</b>	
<ul style="list-style-type: none"> <li>access to properties is provided in recognition of the risk to fire fighters and/ or evacuating occupants.</li> </ul>	<ul style="list-style-type: none"> <li>at least one alternative property access road is provided for individual dwellings (or groups of dwellings) that are located more than 200 metres from a public through road</li> </ul>
<ul style="list-style-type: none"> <li>the capacity of road surfaces and bridges is sufficient to carry fully loaded firefighting vehicles.</li> <li>all weather access is provided.</li> </ul>	<ul style="list-style-type: none"> <li>bridges clearly indicate load rating and pavements and bridges are capable of carrying a load of 15 tonnes</li> <li>roads do not traverse a wetland or other land potentially subject to periodic inundation (other than a flood or storm surge).</li> </ul>
<ul style="list-style-type: none"> <li>road widths and design enable safe access for vehicles</li> </ul>	<ul style="list-style-type: none"> <li>a minimum carriageway width of four metres for rural-residential areas, rural landholdings or urban areas with a distance of greater than 70 metres from the nearest hydrant point to the most external part of a proposed building (or footprint).</li> </ul> <p><i>Note: No specific access requirements apply in a urban area where a 70 metres unobstructed path can be demonstrated between the most distant external part of the proposed dwelling and the nearest part of the public access road (where the road speed limit is not greater than 70kph) that supports the operational use of emergency firefighting vehicles (i.e. a hydrant or water supply).</i></p> <ul style="list-style-type: none"> <li>in forest, woodland and heath situations, rural property access roads have passing bays every 200 metres that are 20 metres long by two metres wide, making a minimum trafficable width of six metres at the passing bay.</li> <li>a minimum vertical clearance of four metres to any overhanging obstructions, including tree branches.</li> <li>internal roads for rural properties provide a loop road around any dwelling or incorporate a turning circle with a minimum 12 metre outer radius.</li> <li>curves have a minimum inner radius of six metres and are minimal in number to allow for rapid access and egress.</li> <li>the minimum distance between inner and outer curves is six metres.</li> <li>the crossfall is not more than 10 degrees.</li> <li>maximum grades for sealed roads do not exceed 15 degrees and not more than 10 degrees for unsealed roads.</li> </ul> <p><i>Note: Some short constrictions in the access may be accepted where they are not less than the minimum (3.5m), extend for no more than 30m and where the obstruction cannot be reasonably avoided or removed. The gradients applicable to public roads also apply to community style development property access roads in addition to the above.</i></p> <ul style="list-style-type: none"> <li>access to a development comprising more than three dwellings have formalised access by dedication of a road and not by right of way.</li> </ul>

### Access (3) – Fire Trails

**Intent of measures: to provide suitable access for fire management purposes and maintenance of APZs**

#### Background

Fire trails are used as access for firefighters, as fire control lines and for APZ maintenance.

In rural-residential subdivisions, they may surround isolated dwellings or groups of dwellings and can form part of the IPA around individual or groups of dwellings.

In suburban subdivisions they may function as a strategic control line around the hazard side of the IPA, if they are connected to the public road system at frequent intervals.

A fire trail is not a substitute for a perimeter road

and any proposals will need to demonstrate clear benefits over the use of a perimeter road. Fire trails are expensive to maintain and can only be effective in the context of a strategic advantage and access for hazard reduction operations.

At the time of subdivision, if fire trails are part of the development, they should be under council management to ensure that maintenance occurs. From time to time this may not be possible, in which case they can occur as easements and rights of way over private land. In these circumstances, the NSW RFS will generally require a community title arrangement to ensure ongoing maintenance.

If fire trails are placed under council management, council is liable for the ongoing costs of maintenance. Given limited funding within many councils, this arrangement does not ensure that maintenance occurs and may place a liability on a council. Where a fire trail is proposed to be vested in council, ongoing funding of maintenance should be considered.

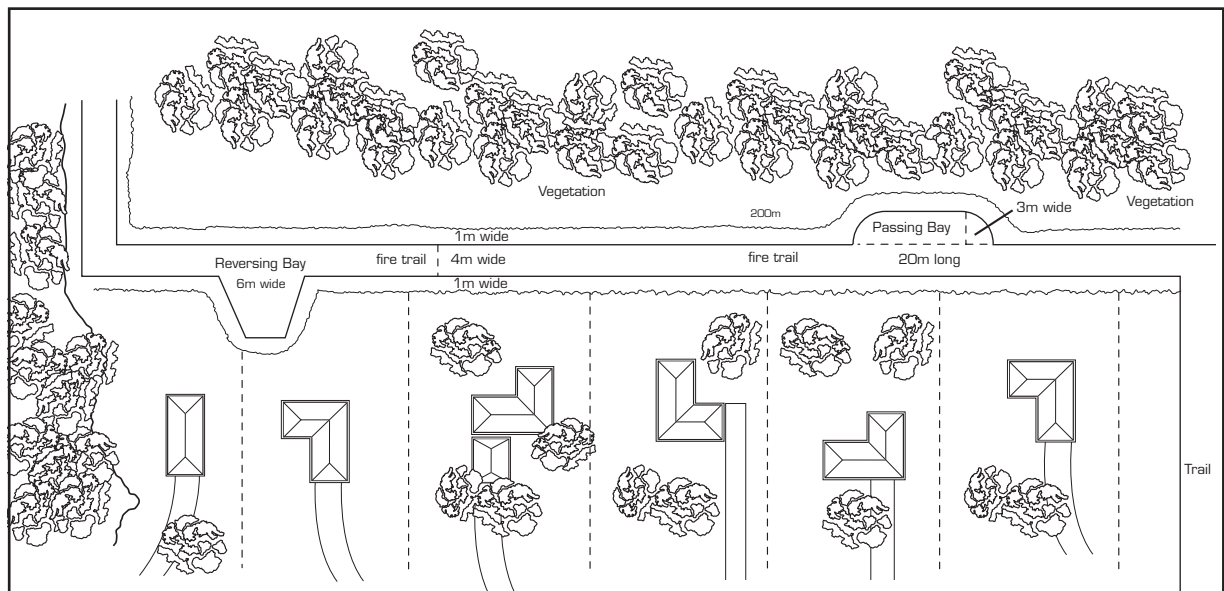

Figure 4.6 Fire Trails may function as strategic control lines if they are connected to the road system at frequent intervals



Fire trail gates are to be provided.

Performance Criteria	Acceptable solutions
<p>The intent may be achieved where:</p>	
<ul style="list-style-type: none"> <li>the width and design of the fire trails enables safe and ready access for firefighting vehicles</li> </ul>	<ul style="list-style-type: none"> <li>a minimum carriageway width of four metres with an additional one metre wide strip on each side of the trail (clear of bushes and long grass) is provided.</li> <li>the trail is a maximum grade of 15 degrees if sealed and not more than 10 degrees if unsealed.</li> <li>a minimum vertical clearance of four metres to any overhanging obstructions, including tree branches is provided.</li> <li>the crossfall of the trail is not more than 10 degrees.</li> <li>the trail has the capacity for passing by: <ul style="list-style-type: none"> <li>reversing bays using the access to properties to reverse fire tankers, which are six metres wide and eight metres deep to any gates, with an inner minimum turning radius of six metres and outer minimum radius of 12 metres; and/or</li> <li>a passing bay every 200 metres, 20 metres long by three metres wide, making a minimum trafficable width of seven metres at the passing bay.</li> </ul> </li> </ul> <p><i>Note: Some short constrictions in the access may be accepted where they are not less than the minimum (3.5m) and extend for no more than 30m and where obstruction cannot be reasonably avoided or removed.</i></p>
<ul style="list-style-type: none"> <li>fire trails are trafficable under all weather conditions. Where the fire trail joins a public road, access shall be controlled to prevent use by non authorised persons.</li> </ul>	<ul style="list-style-type: none"> <li>the fire trail is accessible to firefighters and maintained in a serviceable condition by the owner of the land.</li> <li>appropriate drainage and erosion controls are provided.</li> <li>the fire trail system is connected to the property access road and/or to the through road system at frequent intervals of 200 metres or less.</li> <li>fire trails do not traverse a wetlands or other land potentially subject to periodic inundation (other than a flood or storm surge).</li> <li>gates for fire trails are provided and locked with a key/lock system authorized by the local RFS.</li> </ul>
<ul style="list-style-type: none"> <li>fire trails designed to prevent weed infestation, soil erosion and other land degradation</li> </ul>	<ul style="list-style-type: none"> <li>fire trail design does not adversely impact on natural hydrological flows.</li> <li>fire trail design acts as an effective barrier to the spread of weeds and nutrients.</li> <li>fire trail construction does not expose acid-sulphate soils.</li> </ul>

## Services – Water, electricity and gas

***Intent of measures: to provide adequate services of water for the protection of buildings during and after the passage of a bush fire, and to locate gas and electricity so as not to contribute to the risk of fire to a building***

### Background

During major bush fire events, the preparedness of the dwelling and its occupants may be seriously jeopardised with the loss of basic services (particularly water and electricity).

As part of the development consent process for the construction of a dwelling, it may be necessary to specify the provision of certain services.

Adequate water supply is critical for any firefighting operation, particularly where property protection is envisaged. The amount of water to be supplied may vary with differing geographical and topographical conditions.

In addition, significantly increased densities may draw upon existing water supplies which, if not supplemented, may prove inadequate in the face



*Do not use plastic water storage tanks in bush fire prone areas.*

of a major bush fire event. This requires careful consideration at the subdivision stage to ensure adequate water will be available. Where reticulated supply is inadequate, water can be supplemented with the provision of a dedicated static water supply in the form of tank storage. Where supplementary supplies of water are required, swimming pools, creeks and dams should not be used as a substitute for a dedicated static supply. These sources of water are not considered reliable during drought conditions.

The determination of a guaranteed water supply is one that can only be made by the water supply authority where mains water supply is available.

In rural areas and areas not serviced by reticulated water supplies, the provision of dedicated static water supply is essential. The amount of water is determined on the basis of lot sizes and density of development. Larger subdivisions of smaller lot sizes require less water than developments involving larger lots spread over a large area. Table 4.2 should be used for determining dedicated static water supply requirements based on lot size and character of development.

Maintaining a dedicated water supply for firefighting purposes in rural areas provides opportunities for water replenishment for firefighting tankers and ensures availability of water for property protection by adequately prepared owners.

As protective measures, hose reels and sprinkler systems are encouraged but are considered to be active measures. They must generally be considered as additional to, rather than a substitute for other bush fire protection measures.

Development type	Water requirement
Residential Lots (<1,000m <sup>2</sup> )	5,000 l/lot
Rural-residential Lots (1,000 – 10,000m <sup>2</sup> )	10,000 l/lot
Large Rural/Lifestyle Lots (>10,000 m <sup>2</sup> )	20,000 l/lot
Dual Occupancy	2,500 l/unit
Townhouse/Unit Style (eg Flats)	5,000 l/unit up to 20,000 l maximum.

*Table 4.2 – Dedicated water supply requirements for various non reticulated subdivision developments*

Performance Criteria	Acceptable solutions
<p>The intent may be achieved where:</p>	
<p><b>Reticulated water supplies</b></p> <ul style="list-style-type: none"> <li>water supplies are easily accessible and located at regular intervals</li> </ul>	<ul style="list-style-type: none"> <li>reticulated water supply to urban subdivisions uses a ring main system for areas with perimeter roads.</li> <li>fire hydrant spacing, sizing and pressures comply with AS 2419.1 – 2005. Where this cannot be met, the RFS will require a test report of the water pressures anticipated by the relevant water supply authority. In such cases, the location, number and sizing of hydrants shall be determined using fire engineering principles.</li> <li>hydrants are not located within any road carriageway</li> <li>all above ground water and gas service pipes external to the building are metal, including and up to any taps.</li> <li>the provisions of parking on public roads are met.</li> </ul>
<p><b>Non-reticulated water supply areas</b></p> <ul style="list-style-type: none"> <li>for rural-residential and rural developments ( or settlements) in bush fire prone areas, a water supply reserve dedicated to firefighting purposes is installed and maintained. The supply of water can be an amalgam of minimum quantities for each lot in the subdivision (community titled subdivisions), or held individually on each lot</li> </ul>	<ul style="list-style-type: none"> <li>the minimum dedicated water supply required for firefighting purposes for each occupied building excluding drenching systems, is provided in accordance with Table 4.2.</li> <li>a suitable connection for firefighting purposes is made available and located within the IPA and away from the structure. A 65mm Storz outlet with a Gate or Ball valve is provided.</li> <li>Gate or Ball valve and pipes are adequate for water flow and are metal rather than plastic.</li> <li>underground tanks have an access hole of 200mm to allow tankers to refill direct from the tank. A hardened ground surface for truck access is supplied within 4 metres of the access hole.</li> <li>above ground tanks are manufactured of concrete or metal and raised tanks have their stands protected. Plastic tanks are not used. Tanks on the hazard side of a building are provided with adequate shielding for the protection of fire fighters.</li> <li>all above ground water pipes external to the building are metal including and up to any taps. Pumps are shielded.</li> </ul>
<p><b>Electricity Services</b></p> <ul style="list-style-type: none"> <li>location of electricity services limits the possibility of ignition of surrounding bushland or the fabric of buildings</li> <li>regular inspection of lines is undertaken to ensure they are not fouled by branches.</li> </ul>	<ul style="list-style-type: none"> <li>where practicable, electrical transmission lines are underground.</li> <li>where overhead electrical transmission lines are proposed: <ul style="list-style-type: none"> <li>lines are installed with short pole spacing (30 metres), unless crossing gullies, gorges or riparian areas; and</li> <li>no part of a tree is closer to a power line than the distance set out in accordance with the specifications in 'Vegetation Safety Clearances' issued by Energy Australia (NS179, April 2002).</li> </ul> </li> </ul>
<p><b>Gas services</b></p> <ul style="list-style-type: none"> <li>location of gas services will not lead to ignition of surrounding bushland or the fabric of buildings</li> </ul>	<ul style="list-style-type: none"> <li>reticulated or bottled gas is installed and maintained in accordance with AS 1596 and the requirements of relevant authorities. Metal piping is to be used.</li> <li>all fixed gas cylinders are kept clear of all flammable materials to a distance of 10 metres and shielded on the hazard side of the installation.</li> <li>if gas cylinders need to be kept close to the building, the release valves are directed away from the building and at least 2 metres away from any combustible material, so that they do not act as a catalyst to combustion. Connections to and from gas cylinders are metal.</li> <li>polymer sheathed flexible gas supply lines to gas meters adjacent to buildings are not used.</li> </ul>

## 4.2 Planning controls for Special Fire Protection Purposes

### 4.2.1 Introduction

Special Fire Protection Purpose (SFPP) developments are required to obtain a BFA from the RFS under section 100B of the RF Act. Such developments are also “integrated developments” under section 91 of the EP&A Act.

The nature of SFPPs means that occupants may be more vulnerable to bush fire attack for one or more of the following reasons:

- They may be less educated in relation to bush fire impacts;
- They may have reduced capacity to evaluate risk and to respond adequately to the bush fire threat;
- They may present organisational difficulties for evacuation and or management;
- They may be more vulnerable through stress and anxiety arising from bush fire threat and smoke;
- There may be significant communication barriers;
- Supervision during a bush fire may be difficult; and
- Logistical arrangements for the numbers of residents may be complicated in terms of alternate accommodation, transport, healthcare and food supplies.

### 4.2.2 Types of Special Fire Protection Purpose Developments

In NSW, SFPPs have been identified as:

- (a) a school,
- (b) a child care centre,
- (c) a hospital (including a hospital for the mentally ill or mentally disordered),
- (d) a hotel, motel or other tourist accommodation,
- (e) a building wholly or principally used as a home or other establishment for mentally incapacitated persons,
- (f) housing for older people or people with disabilities within the meaning of State Environmental Planning Policy No 5 - Housing for Older People or People with a Disability (now State Environmental Planning Policy (Seniors Living)).,
- (g) a group home within the meaning of State Environmental Planning Policy No 9 - Group Homes,
- (h) a retirement village,
- (i) any other purpose prescribed by the regulations. (Section 100B (6) of the RF Act).

### 4.2.3 Specific Objectives for Special Fire Protection Purpose Developments

While the “measures in combination” continues as a principle, there is more reliance on space around buildings (as defensible space and APZs for fuel load control) and less reliance on construction standards. The specific objectives at 4.1.2 relating

to the provision of road access, water supply and other services also apply to SFPPs as they do to residential subdivisions.

The specific objectives for SFPP developments are to :

- provide for the special characteristics and needs of occupants. Unlike residential subdivisions, which can be built to a construction standard to withstand the fire event, enabling occupants and firefighters to provide property protection after the passage of fire, occupants of SFPP developments may not be able to assist in property protection. They are more likely to be adversely affected by smoke or heat while being evacuated.
- provide for safe emergency evacuation procedures. SFPP Developments are highly dependent on suitable emergency evacuation arrangements, which require greater separation from bush fire threats.

During emergencies, the risk to firefighters and other emergency services personnel can be high through prolonged exposure, where door-to-door warnings are being given and exposure to the bush fire is imminent.

A bush fire emergency management plan should minimise risks to emergency services personnel and exits should be located away from the hazard side of a building. It is for this reason that setbacks for special fire protection purposes are larger than most normal residential buildings, as the radiant heat exposure can be unacceptable for emergency workers assisting residents in the open compared to being inside the building.

In all cases the intent and performance criteria of each BPM must be satisfied, as per the Performance Tables that follow (see section 4.2.7). Exceptional circumstances must be demonstrated for reductions in APZ (required by Appendix 2) or APZ on adjoining land (see section 3.3).

### 4.2.4 Matters for consideration for specific SFPPs

The following commentary outlines particular matters for consideration for specific types of SFPP developments.

#### a) Schools

While schools are usually associated with primary and secondary students, the description covers all school purposes and includes any development in which schooling can take place.

This includes schools for religious instruction as well as child learning centres.

Universities and technical colleges are not defined as a school within an LEP, however these require careful consideration, and the specific objectives above should be applied.

Schools are particularly prone to traffic-generated congestion on roads at start and finish times. This is heightened when parents believe that their children are likely to be exposed to bush fire and in seeking to reach the school, cause road congestion and hamper the firefighting effort.

In general, office buildings for administration are not afforded the same protection as classrooms or assembly point buildings used for evacuation. Likewise, toilet blocks can be located within the APZ area.

Sporting fields, and amenities blocks should form part of the APZ between the hazard and classrooms. Car parking should be near a clear exit away from the bush fire threat.

Efforts must be made to improve the resilience of buildings, and new classrooms should not be extended towards bushland where they do not comply with the setback requirements of Appendix 2. Where existing schools do not meet setback requirements any upgrades should incorporate improved bush fire protection measures within existing building footprints.

#### b) Child care centres

Child care centres often have fixed ratios of staff to children that are based on supervision rather than emergency response and evacuation requirements. It is one of the reasons that child care centres are considered special fire protection purpose developments. Of particular concern is where buildings such as dwellings are proposed to be converted to child care centres, as existing housing stock is unlikely to meet basic ember protection in a bush fire prone area.

When extending or upgrading the buildings of an existing child care centre, no part of a building should be located closer to the fire threat than permitted by the applicable construction standard (AS 3959-1999). This may result in a level of retrofitting of existing buildings to ensure improved safety.

#### c) Hospitals (including hospitals for the mentally ill or mentally disordered)

Hospitals can vary significantly in size and purpose. They may be larger public hospitals or smaller private day surgery premises.

Hospitals are harder to design with bush fire protection in mind. They require ease of access for emergency patients arriving by ambulance or car with larger doorways that are difficult to ember proof.

Patients can have a range of physical conditions and most emergency plans are based on fire within the building rather than bush fire threat. In many cases patients could suffer from asthma, emphysema or obstructive diseases and smoke may exacerbate these conditions. People with emotional or psychological problems may suffer increased anxiety and unwarranted stress during a

bush fire, making evacuation arrangements difficult to coordinate and implement. A building wholly or principally used as a home or other establishment for mentally incapacitated persons has the same difficulties.

#### d) Hotels, motels and other tourist accommodation

This class of development includes large hotels, motel accommodation, bed and breakfast establishments (B&Bs), caravan parks (and mobile home estates), lodges, religious and health retreats and camping grounds.



*Caravan parks and mobile homes (relocatable) estates are considered SFPP.*

The biggest challenge is evacuation of people who may have no comprehension of the danger or knowledge of the area in which they find themselves. Tourists staying in tourist accommodation have been known to evacuate late or travel down inappropriate roads with fatal results. A better strategy may either be staying within a resilient building as a refuge or having coordinated escorted evacuation.

In some cases, the attraction of the site as a bush land setting conflicts with the need for adequate APZs, however, this should not lead to a lower standard of construction or unsuitable access being provided.

#### Eco-tourism

A major challenge arises with 'eco-tourism' facilities in which accommodation has traditionally been built into a remote bushland environment. Eco-tourism aims to foster environmental and cultural understanding, appreciation and conservation, be ecologically sustainable and based on relatively undisturbed natural areas.

Clearly this can conflict with bush fire safety objectives, which aim to reduce a building's vulnerability to ignition from heat radiation, flame or embers and to provide safe access and a minimum defensible space for firefighter safety. Access can also be problematic and the requirements for access possibly across adjoining properties will need to be carefully assessed. This should recognise the risk faced by fire fighters trying to gain access and occupants trying to evacuate to safer areas (see page 39).

### e) State Environmental Planning Policy (SEPP) – Seniors Living

The policy aims to increase the supply and diversity of housing to meet the needs of older people or people with a disability, while making efficient use of existing infrastructure and services. The policy does not apply to land described as 'environmentally sensitive land' which can include land identified as being bush fire prone land. Consequently SEPP Seniors Living proposals may not be permitted in these areas.

The nature of Seniors Living developments determines that a relatively less mobile residential population is present and, as such, creates difficulties when evacuation is required. These residents cannot generally be expected to defend the property from bush fire attack.

SEPP Seniors Living can be accessed on the NSW Parliamentary Legislation website at [www.legislation.nsw.gov.au](http://www.legislation.nsw.gov.au).

The consent authority is also required under the Policy to consider **additional matters** for SEPP Seniors Living developments in the vicinity of bush fire prone land and take into consideration the means of access to the general location and other relevant matters.

In these cases, the consent authority must also consult with the Commissioner of the RFS. The requirements on this type of development are of a higher order than other special fire protection purpose developments.

In addition, it should be noted that some consent authorities deal with seniors living facilities through the provisions of their LEP.



*Senior living and retirement/nursing homes require special consideration in relation to APZs*

### f) State Environmental Planning Policy No 9 - Group Homes

The aim of the SEPP 9 Policy is to facilitate the establishment of:

*“(a) permanent group homes in which disabled persons or socially disadvantaged persons may lead as normal a life as possible by living permanently in an ordinary residential household environment, instead of in an institutional environment, and (b) transitional group homes which provide temporary accommodation for disabled persons or socially disadvantaged persons in an ordinary residential household environment instead of in an institutional environment for purposes such as alcohol or drug rehabilitation, “half-way” rehabilitation for persons formerly living in institutions and refuges for men, women or young people.”*

As with other SFPP developments, major issues relate to evacuation planning arrangements and access to the property. Although having higher population densities than most residential homes, SEPP 9 developments tend not to be as intense as hospitals or other special fire protection purpose developments. Group Home developments approved under an LEP, are also captured as SFPP developments.

### g) Retirement villages

Retirement villages have the same issues as SEPP (Seniors Living) developments, often with various levels of care available from totally independent living to daily care arrangements.

### 4.2.5 SFPPs as infill

In circumstances where alterations or additions to existing SFPP's facilities are proposed, the RFS requires an appropriate combination of bush fire protection measures and compliance with the intent and performance criteria of each measure within section 4.3.5.

However, it is also acknowledged that existing circumstances may make the preferred standards difficult to achieve. In such cases, the specific objectives in Section 4.2.3 are to be followed.

Alterations and additions to existing SFPP's (i.e. approved prior to 1st August 2002), including their external appearance or finish, which may involve an increase in size and footprint of the building or redevelopment of an existing building are considered to be infill development.

This type of development should also seek to achieve a better bush fire risk outcome (such as improved construction standards) than if the development did not proceed. The new building work should comply with AS 3959 - 1999 (and Appendix 3 of PBP) or be no closer to the hazard than the existing building. Existing facilities such as water supply should also be upgraded.

### a) Alpine resorts

The NSW Alpine resort areas are:

- The Perisher Range – Perisher, Smiggin Holes, Blue Cow and Guthega.
- Thredbo Alpine Village
- Charlottes Pass
- Mount Selwyn
- Ski Rider
- Kosciuszko Mountain Retreat
- Sponars Chalet
- Bullocks Flat

These resort areas, located in the Kosciuszko National Park (KNP), are leased from the Department of Environment and Conservation (DEC) and are unique in NSW. They are centres of intensive, seasonally based recreation that have different types of habitable buildings used principally for short term tourist accommodation, with the maximum numbers of visitors coming to the area in winter.

Due to the elevation of the resort areas, vegetation types, slope and climate of the area the bushfire risks are inherently different to those experienced on the eastern seaboard. The normal fire season within the KNP extends for a short period from January through to March.

Land surrounding the developed lease areas is under the management of DEC and contains areas of habitat for vulnerable and endangered flora and fauna. As a result, fuel reduction strategies and asset protection zones need to be handled carefully to avoid inconsistency with the objectives of SEPP 73 and the *National Parks and Wildlife Act 1974*.

Additionally, infill development in these areas would include alterations or variations to lease boundaries that did not result in the construction of new buildings.



*Alpine resorts still require an appropriate combination of bush fire protection measures. (Table A3.5 applies, page 65)*

### b) Bed and Breakfasts and Holiday Lets

When an application is made for a change of use for the establishment of B&Bs and holiday lets, these fall within the SFPP definition. Access and water are critical for such developments and where these do not provide suitable access away from the fire hazard, these developments should not be allowed.

Where conversion to a B&B or holiday let is proposed in an area with reticulated water, it does not back onto public reserves, and the setback and construction requirements of AS 3959 - 1999 can be applied (or are shielded by other forms of development), they should be treated as an infill arrangement.

#### 4.2.6 Applying SFPP objectives to other types of development

Many Class 9 buildings under the BCA are considered 'assembly areas' and may attract significant numbers of people for various purposes including entertainment, religious instruction, sport or education. Prisons, churches, tertiary education institutions (eg universities) and similar land uses also fall within this definition and all accommodate large numbers of persons of various physical capabilities. The major issue in these situations is to determine whether staff or other occupants have a capacity for firefighting response and /or adequate emergency and evacuation planning in place.

Churches, in particular, have lower occupancy periods being largely occupied on weekends or for shorter periods during the week. In the past it was often the rectories that were lost rather than churches, possibly associated with the stone or brick construction materials used.

These types of developments (ie Class 9 buildings) should be considered on their merits under sections 79BA and 79C of the EP&A Act, with consideration of the specific objectives listed in 4.2.3.

Overall, those Class 9 buildings not being a SFPP should be considered as if they were a SFPP.

These buildings will not have specific bush fire provisions applying under the BCA, but their location should be carefully considered.

In such cases the aim and objectives of PBP should be used to assess the merits of the proposal.

#### 4.2.7 Standards for Bush Fire Protection Measures for Special Fire Protection Purpose Developments

##### Asset protection zones

***Intent of measures: to provide sufficient space for firefighters and other emergency services personnel, ensuring radiant heat levels permit operations under critical conditions of radiant heat, smoke and embers, while supporting or evacuating occupants.***

##### Background

Experience has shown that certain types of developments have occupants who are highly vulnerable to the effects of bush fire events. This arises from their susceptibility to the effects of fire, lower mobility, adverse health effects, lack of comprehension of the risk being faced during a fire or, simply, high levels of care during an emergency event.

In the event of a bush fire, these residents may be difficult to evacuate and/or more susceptible to smoke impacts. They are also generally unable to assist with property protection.

It is for these reasons that the concept of SFPP development was introduced and that APZ distances are the key BPM.

Some developments such as SEPP Seniors Living developments are often marketed to those who are not necessarily considered vulnerable although the development may be designed specifically for aged persons or persons with a disability. Clearly a conservative approach is required.

It is also anticipated that certain types of development are hard to ember proof due to the access arrangements needed. Schools and hospitals are good examples.

Radiant heat levels of  $>10\text{kW}/\text{m}^2$  must not be experienced by emergency services workers aiding residents within a special fire protection purpose development. Where ember protection is not feasible, then setbacks greater than 100 metres from bushland should be adopted.



*The intent of an APZ is to provide sufficient space for firefighters and other emergency services personnel, ensuring radiant heat levels permit operations under critical conditions of radiant heat, smoke and embers, while supporting or evacuating occupants.*

Performance Criteria	Acceptable solutions
<p>The intent may be achieved where:</p>	
<ul style="list-style-type: none"> <li>radiant heat levels of greater than 10kW/m<sup>2</sup> will not be experienced by occupants or emergency services workers entering or exiting a building.</li> </ul>	<ul style="list-style-type: none"> <li>an APZ is provided in accordance with the relevant tables and figures in Appendix 2 of this document.</li> <li>exits are located away from the hazard side of the building.</li> <li>the APZ is wholly within the boundaries of the development site. Exceptional circumstances may apply (see section 3.3)</li> </ul>
<ul style="list-style-type: none"> <li>applicants demonstrate that issues relating to slope are addressed: maintenance is practical, soil stability is not compromised and the potential for crown fires is negated.</li> </ul>	<ul style="list-style-type: none"> <li>mechanisms are in place to provide for the maintenance of the APZ over the life of the development.</li> <li>the APZ is not located on lands with a slope exceeding 18 degrees.</li> </ul>
<ul style="list-style-type: none"> <li>APZs are managed and maintained to prevent the spread of a fire towards the building.</li> </ul>	<ul style="list-style-type: none"> <li>in accordance with the requirements of 'Standards for Asset Protection Zones (RFS 2005).</li> </ul> <p><i>Note - a Monitoring and Fuel Management Program should be required as a condition of development consent.</i></p>
<ul style="list-style-type: none"> <li>vegetation is managed to prevent flame contact and reduce radiant heat to buildings, minimise the potential for wind driven embers to cause ignition and reduce the effect of smoke on residents and fire-fighters.</li> </ul>	<ul style="list-style-type: none"> <li>compliance with Appendix 5.</li> </ul>

## Access – Internal Roads

***Intent of measures: to provide safe operational access for emergency services personnel in suppressing a bush fire, while residents are accessing or egressing an area***

### Background

The public road system in a bush fire prone area should provide alternative access or egress for firefighters and residents during a bush fire emergency if part of the road system is cut by fire. This is of critical importance for areas with the higher densities associated with SFPP developments.

Where those developments are being established, the requirements for public roads and car parking apply in the same way as new residential subdivisions. (See Section 4.1.3, Access - Public Roads)

The impact of increased traffic and traffic management in the neighbouring areas also needs to be considered and an assessment of impact on fire fighting capacity undertaken.

For internal roads, at least one alternative access road needs to be provided for individual dwellings or groups of dwellings more than 200 metres from a public through road. The routes of these roads should be selected to ensure that both roads are unlikely to be simultaneously cut by a fire.

Short access roads are preferable to long ones for the safe evacuation of residents and for emergency service personnel. Therefore dwellings should be sited as close as possible to public through roads.

Large numbers of vehicles may be attempting to simultaneously enter or leave an area, congesting roads and restricting fire services and other emergency services personnel accessing an area. For this reason, roads should be planned for suitable widths to permit access into and out of the area during such situations.



*Hydrants should not be placed in parking areas (top photo) but within footpaths (middle photo). Access including road curvatures should allow ready movement of fire fighting vehicles.*

Performance Criteria	Acceptable solutions
<p>The intent may be achieved where:</p>	
<ul style="list-style-type: none"> <li>internal road widths and design enable safe access for emergency services and allow crews to work with equipment about the vehicle.</li> </ul>	<ul style="list-style-type: none"> <li>internal roads are two-wheel drive, sealed, all-weather roads;</li> <li>internal perimeter roads are provided with at least two traffic lane widths (carriageway 8 metres minimum kerb to kerb) and shoulders on each side, allowing traffic to pass in opposite directions;</li> <li>roads are <b>through</b> roads. Dead end roads are not more than 100 metres in length from a through road, incorporate a minimum 12 metres outer radius turning circle, and are clearly sign posted as a dead end;</li> <li>traffic management devices are constructed to facilitate access by emergency services vehicles.</li> <li>a minimum vertical clearance of four metres to any overhanging obstructions, including tree branches, is provided.</li> <li>curves have a minimum inner radius of six metres and are minimal in number to allow for rapid access and egress.</li> <li>the minimum distance between inner and outer curves is six metres.</li> <li>maximum grades do not exceed 15 degrees and average grades are not more than 10 degrees.</li> <li>crossfall of the pavement is not more than 10 degrees.</li> <li>roads do not traverse through a wetland or other land potentially subject to periodic inundation (other than flood or storm surge).</li> <li>roads are clearly sign-posted and bridges clearly indicate load ratings.</li> <li>the internal road surfaces and bridges have a capacity to carry fully-loaded firefighting vehicles (15 tonnes).</li> </ul>



Property access should not restrict firefighting access. Bridge loadings should be clearly marked.

## Services – Water, gas and electricity

***Intent of measures: to provide adequate water services for the protection of buildings during and after the passage of a bush fire, and to locate gas and electricity so as not to contribute to the risk of fire to buildings***

### Background

During major bush fire events, the protection and preparedness of SFPP developments and their occupants may be seriously jeopardised by the loss of basic services. This is particularly important

where residents rely on the use of medical equipment for their welfare or survival.

Adequate water supply is critical for any firefighting operation and particularly where property protection is envisaged. Water supplies must be easily accessible and located at regular intervals. The amount of water to be supplied may vary with differing geographical and topographical conditions.

In SFPP areas, reticulated water should be available for firefighting purposes and fire hydrants should be regularly spaced and comply with Australian Standards (AS 2419.1 - 2005). Where mains water supply is available, the determination of a guaranteed water supply can only be made by the water supply authority.



*Pumps and other fittings need to be shielded and made of non-combustible materials.*

Performance Criteria	Acceptable solutions
<p>The intent may be achieved where:</p>	
<p><b>Reticulated water supplies</b></p> <ul style="list-style-type: none"> <li>water supplies are easily accessible and located at regular intervals.</li> </ul>	<ul style="list-style-type: none"> <li>access points for reticulated water supply to SFPP developments incorporate a ring main system for all internal roads.</li> <li>fire hydrant spacing, sizing and pressures comply with AS 2419.1 – 2005. Where this cannot be met, the RFS will require a test report of the water pressures anticipated by the relevant water supply authority, once development has been completed. In such cases, the location, number and sizing of hydrants shall be determined using fire engineering principles.</li> <li>the provisions of public roads in section 4.1.3 in relation to parking are met.</li> </ul>
<p><b>Non-reticulated water supply area.</b></p> <ul style="list-style-type: none"> <li>a water supply reserve dedicated to firefighting purposes is installed and maintained. The supply of water can be an amalgam of minimum quantities for each lot in the development and be reticulated within dedicated firefighting lines.</li> </ul>	<ul style="list-style-type: none"> <li>10,000 litres is the minimum dedicated water supply required for firefighting purposes for each occupied building, excluding drenching systems.</li> <li>the provision for suitable connection for RFS and/or NSW Fire Brigades purposes in section 4.1.3 in relation to water supplies is made available.</li> </ul>
<p><b>Electricity</b></p> <ul style="list-style-type: none"> <li>location of electricity services will not lead to ignition of surrounding bushland or the fabric of buildings or risk to life from damaged electrical infrastructure.</li> </ul>	<ul style="list-style-type: none"> <li>electrical transmission lines are underground.</li> </ul>
<p><b>Gas</b></p> <ul style="list-style-type: none"> <li>location of gas services will not lead to ignition of surrounding bush land or the fabric of buildings.</li> </ul>	<ul style="list-style-type: none"> <li>reticulated or bottled gas is installed and maintained in accordance with AS 1596 - 2002 and the requirements of relevant authorities. Metal piping is to be used.</li> <li>all fixed LPG tanks are kept clear of all flammable materials and located on the non hazard side of the development.</li> <li>If gas cylinders need to be kept close to the building, the release valves must be directed away from the building and away from any combustible material, so that they do not act as catalysts to combustion.</li> <li>polymer sheathed flexible gas supply lines to gas meters adjacent to buildings are not to be used.</li> </ul>

## Emergency and evacuation planning

***Intent of measures: to provide suitable emergency and evacuation (and relocation) arrangements for occupants of special fire protection purpose developments.***

### Background

A decision to stay and defend a well-prepared property or to leave early should be made well in advance of the arrival of a bush fire, and people who intend to relocate themselves should do so as early as possible.

It is also recognised that people who cannot cope with bush fire should relocate well before a fire impacts on their location, and that there should be an identified 'trigger' used to initiate an emergency or relocation plan. Relocation in advance of a bush fire is not always possible however.

Appropriately prepared and constructed buildings offer protection during bush fires reducing the likelihood of bush fire related injury and fatality.



Evacuation at the last minute ahead of a bush fire is very dangerous, and potentially exposes people to smoke, radiant heat and embers. It is for this reason that SFPP developments have increased setback requirements to meet evacuation/relocation and emergency planning objectives and also have a requirement for site specific emergency plans.

This is particularly important where the affected people are very young or aged, or where the population is poorly prepared for the bush fire event, either because of a lack of understanding (e.g. tourists) or limited language skills (e.g. recent migrants).

SEPP Seniors Living, schools, hospitals, child care, nursing homes and other SFPPs should all have suitable management arrangements and structures capable of developing and implementing an emergency plan. This should also be the case for 'community title' type arrangements.

Where eco-tourist facilities are planned they should have low accommodation levels (generally less than 12 persons) so as to facilitate relocation and emergency planning, and be located within 100 metres of a public road or 50 metres from a major refuge away from any forested or heathland areas.



Arrangements should be included for communications with local fire fighting e.g. RFS control centres so that fire activity can be monitored by trained fire service staff.

***The Emergency and Evacuation Plan embodies a risk assessment and the necessary procedures to minimize the potential impact of a bush fire. An emergency/evacuation plan provides employees and residents with the procedures to either enable premises to be suitable refuges or to evacuate or relocate, as appropriate, in the event of a bush fire.***

Performance Criteria	Acceptable solutions
<p><b>The intent may be achieved where:</b></p>	
<ul style="list-style-type: none"> <li>• an Emergency and Evacuation Management Plan is approved by the relevant fire authority for the area.</li> </ul>	<ul style="list-style-type: none"> <li>• an emergency/evacuation plan is prepared consistent with the RFS Guidelines for the <i>Preparation of Emergency/Evacuation Plan</i>.</li> <li>• compliance with AS 3745-2002 'Emergency control organisation and procedures for buildings, structures and workplaces' for residential accommodation'.</li> <li>• compliance with AS 4083-1997 'Planning for emergencies - for health care facilities'.</li> </ul> <p><i>Note: The developer should provide a copy of the above document to the local Bush Fire Management Committee for their information prior to the occupation of any accommodation of a special fire protection purpose or community title subdivision.</i></p>
<ul style="list-style-type: none"> <li>• suitable management arrangements are established for consultation and implementation of the emergency and evacuation plan.</li> </ul>	<ul style="list-style-type: none"> <li>• an Emergency Planning Committee is established to consult with residents (and their families in the case of aged care accommodation and schools) and staff in developing and implementing an Emergency Procedures Manual.</li> <li>• detailed plans of all Emergency Assembly Areas including "onsite" and "offsite" arrangements as stated in AS 3745-2002 are clearly displayed, and an annual (as a minimum) trial emergency evacuation is conducted.</li> </ul>
<p><b>In relation to eco-tourist accommodation:</b></p> <ul style="list-style-type: none"> <li>• suitable refuge areas and evacuation/management arrangements are in place commensurate with the bush fire risk.</li> </ul>	<ul style="list-style-type: none"> <li>• at least one building should be used as a local refuge area and comply with the APZ's and construction requirements for residential buildings.</li> <li>• cabins are within 50 metres of a refuge building and are clearly signposted.</li> <li>• the paths from cabins to the refuge area are safe, with management of surface fuels to <math>\leq 4</math> tonnes/ha.</li> <li>• the overall accommodation for tourists does not exceed 12 persons.</li> <li>• a mechanism for the relocation of occupants on days of a total fire ban or adverse fire activity is provided in the local area in which the development operates.</li> </ul>

## 4.3 Planning controls for infill and other developments on bush fire prone land

### 4.3.1 Introduction

Section 79BA of the EP&A Act requires compliance with PBP for all development proposals on bush fire prone land. Those types of development covered in Sections 4.1 and 4.2 are special, requiring compliance. They also require a s100B BFSAs from the RFS under the RF Act.

Development other than such subdivisions or SFPPs would often be classed as infill development (as defined). This includes new houses, alterations and additions in existing subdivisions.

Other types of development on bush fire prone land (e.g. commercial, industrial, other subdivisions) are also addressed through the aim and objectives of this document (see section 1.1). In some cases, specific advice is provided.

There is considerable common ground between "other" development and subdivision or SFPP developments:

- the same range of bush fire protection measures can apply; and
- APZ is the principal element, especially its subset, defendable space.

There are also key differences. Because most applications will be infill, consideration of existing circumstances and the need for careful site analysis is crucial.

### 4.3.2 Specific Objectives for infill

Proposals for infill development are to:

- ensure that the bush fire risk to adjoining lands is not increased;
- provide a minimum defendable space;
- provide better bush fire protection, on a re-development site, than the existing situation. This should not result in new works being exposed to greater risk than an existing building;
- ensure that the footprint of the proposed building does not extend towards the hazard beyond existing building lines on neighboring land;
- not result in an increased bush fire management and maintenance responsibility on adjoining land owners unless they have agreed to the development; and
- ensure building design and construction enhance the chances of occupant and building survival.

Ideally, APZs, access and service supply standards for infill developments should be provided in accordance with the acceptable solutions applied to residential subdivision (see section 4.1).



*Other types of development (e.g. commercial, industrial) are also addressed through the aim and objectives of this document (see section 1.1)*

However, in most cases, infill development proposals will be constrained by existing situations – pre-existing subdivision patterns and existing built forms surrounding the subject site. Consequently, each proposal must be considered on its merits and in accordance with the intent and performance criteria for infill development (section 4.3.5).

An underlying principle is that the larger the scale of development, the greater the need to comply with the APZ, access and service requirements.

### 4.3.3 Consultation with the RFS

Residential infill development that does not comply with the acceptable solutions within the performance table in section 4.3.5 (e.g. construction requirements within Appendix 3) should be referred by the consent authority to the Commissioner of the RFS for advice under section 79BA of the EP&A Act (see section 2.7).



*Consultation with RFS Officers*

The purpose of consultation under section 79BA of the EP&A Act is to consider an appropriate performance based solution. The onus is still on the applicant to develop such a solution.

### 4.3.4 The role of construction standards for residential infill

The provisions of the BCA in NSW (and therefore Appendix 3 of this document) apply to residential development, Classes 1, 2 and 4 (Class 3 buildings will usually be an SFPP).

In preparing a development application under section 79BA, the applicant may consider the provision of higher-level construction standards as a level of equivalence for the inability to provide the required APZ. Consideration may also be given to additional measures such as drenching systems, radiant heat shields and shutters to satisfy the performance criteria.

As discussed in section 2.6, this commits applicants to the construction level or performance solution for the associated Construction Certificate (CC).



*Additions and extensions need to meet construction requirements associated with the main building*

### 4.3.5 Specifications and Requirements for Bush Fire Protection Measures for Infill Development

#### Infill Development

**Intent of measures: to minimise the risk of bush fire attack and provide protection for emergency services personnel, residents and others assisting firefighting activities.**

#### Background

The requirement to address bush fire protection for subdivision (and other development) was introduced on 1 August, 2002. As a result, pre-existing subdivisions may not provide the levels of protection currently required.

Where a development expectation arises from the zoning of the land to build, rebuild, alter or add to a dwelling(s) in pre-existing subdivisions, attempts should be made to find a solution taking into account the level of risk present. The expectation of building or altering a house is recognised even though the ability to provide for APZs or access requirements now required for residential development may not be possible.

Proposals to reduce APZ requirements or utilise adjoining lands need to consider the advice on exceptional circumstances in section 3.3.

In such circumstances, greater emphasis may be placed on siting, design, construction standards and landscaping and the maintenance of these systems. Vegetation management practices may be required to ensure improved levels of protection are afforded the development, its occupants and firefighters.

Where a development falls 'outside of the scope' of the construction requirements of PBP (ie the deemed-to-satisfy arrangements of the BCA applicable in NSW), then a performance solution will need to be developed for the construction aspects of the building. In some circumstances, the proposed building's scale and size may need to be modified to ensure a defensible space and reduce bush fire attack.

Increasing densities within bush fire prone areas is not of itself considered to be an exceptional circumstance. Where three or more dwellings are proposed for a single allotment the development will be treated as being subject to subdivision and hence the requirements of section 4.1 will be applied.

In general, additions, alterations or extensions to a building will be treated as infill for class 1, 2, 3 and 4 buildings not being a SFPP.

The design of a building can be of critical importance in terms of the potential for accumulation of debris and exposure of the building to bush fire attack.

The higher the building and greater its bulk, the greater the exposure of the building to radiant heat, wind turbulence and ember attack. Reduction in the area of exposure may be important for critical elements such as windows, doors, roofs and wall claddings. Clearly some cladding materials such as brickwork are more robust.

Intricate forms of design can trap debris and influence wind turbulence. Re-entrant corners may aid the architectural interest of the building but readily accumulate debris and some roof designs are unnecessarily complicated. For two storey buildings, the use of gutters on the upper story makes debris removal more difficult. Many people are hospitalised as the result of falling off roofs whilst attempting last minute maintenance in awkward areas or to higher gutters in the face of an impending bush fire. The use of box gutters, flat roofs and variations in the angle of the roof should be avoided.

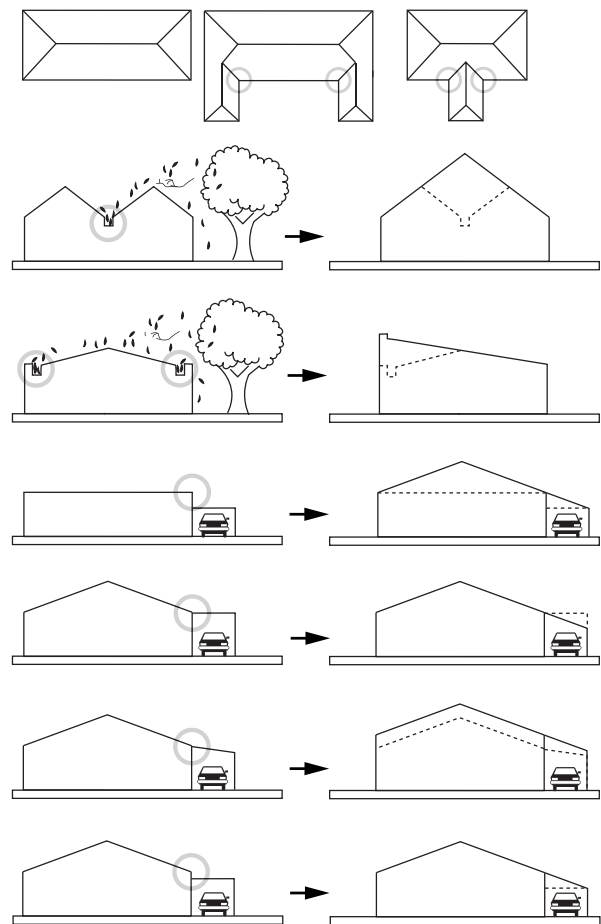
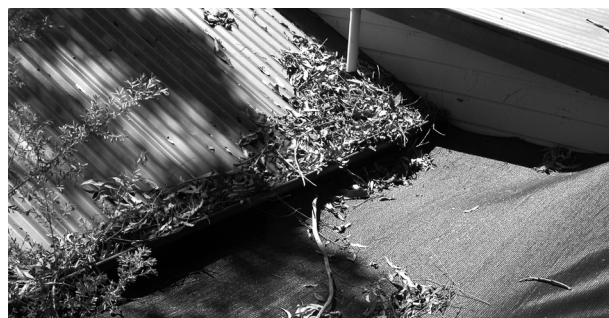

Figure 4.7 Design aspects for buildings (adapted from Ramsay, C and Rudolph, 2003)

Some design features can enhance the protection of a building, including limiting glazing on exposed facades and barriers, eg courtyard or fenced off area for gardens, BBQ areas and the like, can be incorporated into building design. Glazing is one element of a building that is highly susceptible to the impacts of radiant heat and flying debris. In addition, a large proportion of radiant heat can pass through a window and heat internal furnishings such as carpets, curtains or furniture.

Performance Criteria	Acceptable solutions
<b>The intent may be achieved where:</b>	
<b>in relation to Asset Protection Zones:</b> <ul style="list-style-type: none"> <li>a defensible space is provided onsite.</li> <li>an asset protection zone is provided and maintained for the life of the development.</li> </ul>	<ul style="list-style-type: none"> <li>APZ determined in accordance with Appendix 2.</li> </ul>
<b>in relation to siting and design:</b> <ul style="list-style-type: none"> <li>buildings are sited and designed to minimise the risk of bush fire attack.</li> </ul>	<ul style="list-style-type: none"> <li>buildings are designed and sited in accordance with the siting and design principles in this section (see also figure 4.7).</li> </ul>
<b>in relation to construction standards:</b> <ul style="list-style-type: none"> <li>it is demonstrated that the proposed building can withstand bush fire attack in the form of wind, smoke, embers, radiant heat and flame contact .</li> </ul>	<ul style="list-style-type: none"> <li>construction determined in accordance with Appendix 3 and the <i>Requirements for attached garages and others structures</i> in this section.</li> </ul> <p><i>Note: provisions in relation to Class 10a buildings may also apply.</i></p>
<b>in relation to access requirements:</b> <ul style="list-style-type: none"> <li>safe, operational access is provided (and maintained) for emergency services personnel in suppressing a bush fire while residents are seeking to relocate, in advance of a bush fire, (satisfying the intent and performance criteria for access roads in sections 4.1.3 and 4.2.7).</li> </ul>	<ul style="list-style-type: none"> <li>compliance with section 4.1.3 for property access roads.</li> <li>compliance with section 4.2.7 for access standards for internal roads.</li> </ul>
<b>in relation to water and utility services:</b> <ul style="list-style-type: none"> <li>adequate water and electricity services are provided for firefighting operations</li> <li>gas and electricity services are located so as not to contribute to the risk of fire to a building.</li> </ul>	<ul style="list-style-type: none"> <li>compliance with section 4.1.3 for services - water, electricity and gas.</li> </ul>
<b>in relation to landscaping:</b> <ul style="list-style-type: none"> <li>it is designed and managed to minimise flame contact and radiant heat to buildings, and the potential for wind driven embers to cause ignitions.</li> </ul>	<ul style="list-style-type: none"> <li>compliance with Appendix 5.</li> </ul>

Note: the above specifications and requirements only apply in relation to infill developments and not “other” developments referred to in section 4.3.6. However, the above specifications and requirements may be used to guide in the development of bush fire protection measures for “other” developments.



Poor design does not aid flushing of debris

Where the internal radiant heat exposure of furnishing rises to a level in excess of  $10\text{kW}/\text{m}^2$ , the possibility of the establishment of an internal fire increases. In many cases, barriers may be incorporated into the building design.

The performance of a building should be enhanced through the following siting and design principles:

- avoid building on ridge tops and saddles;
- building on level ground wherever possible;
- where buildings must be constructed on sloping land, they are built on cut-in benches rather than elevated or above fill;
- avoid raised floors, utilise concrete slabs (raft construction);
- locating the habitable buildings near the property entrance for easier access/egress;
- the use of non-combustible fencing (or other class 10a buildings) which is located within close proximity to the main building;
- reducing the bulk of a building (height and width) facing a bush fire hazard;
- simplifying the design of buildings to reduce the numbers of re-entrant corners;
- providing more simplified rooflines;
- guttering and gutter valleys being:
  - ♦ installed with gutter guarding having a flammability index of not more than 5, when tested to AS 1530.2;
  - ♦ limited to the lowest possible levels (bottom fascia) to improve access and maintenance; and
  - ♦ covered with a mesh of aluminium bronze or stainless steel with a maximum aperture of 5 mm fixed to the outer edge of the gutter (or valley) and be located beneath the second (or higher) row of tiles or roof sheeting for a distance of 250mm;

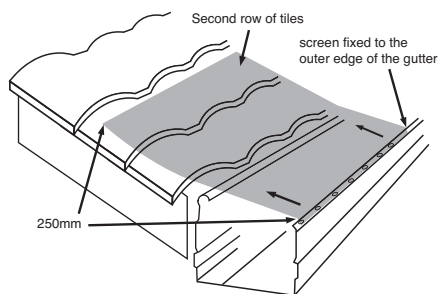

Figure 4.8  
Leafless gutters enhance building performance

- use of barriers (e.g. courtyards, fenced off areas for gardens, BBQ areas and the like); and
- where garages are located under the roofline of the main building, garage doors are to be ember proofed and employ ember traps and or brushes to prevent the entry of embers into the garage area (see requirements for garages and other structures in adjacent text box);

Where free standing vegetation is located upslope of the dwelling, provision of a radiant heat barrier should be close to the building for additional protection. For vegetation located downslope of the structure the radiant heat barrier is most

effective when it is located along the boundary and is up to two metres in height.

### Requirements for attached garages and other structures

Where a garage or other attached structure has a common roof space with a building required to comply with any level of construction, the entire garage, carport, veranda or similar roofed structure is assessed as part of the building and must comply with the relevant construction requirements as if it were the subject building,

### Adjacent structures

Where any garage, carport, veranda or similar roofed structure is not attached to a building required to comply with a level of construction, the entire garage, carport, veranda or similar roofed structure is to be—

- assessed as if it were a building required to comply with the appropriate level of construction; or
- separated by a distance of greater than 10 metres from the building required to comply with the appropriate level of construction.

### Garage Doors

Garage doors are to be:

- tight fitting to door frames and jambs with gaps no greater than 5 mm when closed; and
- where a roller shutter door is installed it shall be provided with an ember protection device at the top of the shutter that captures any embers where a gap of 2.0 mm on the external surface exists.

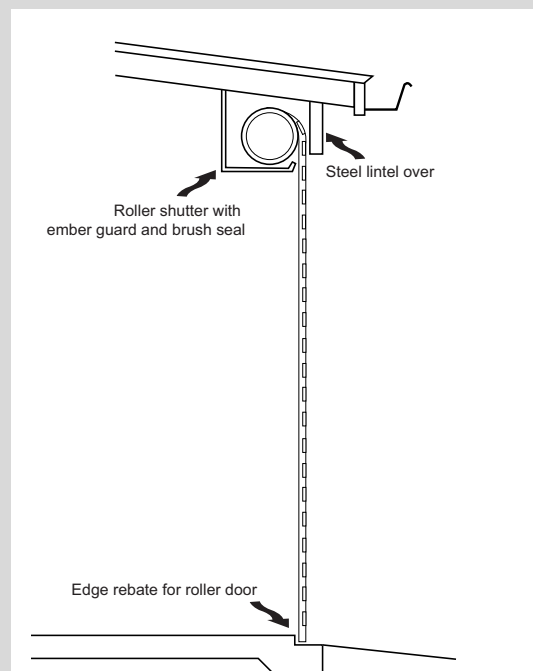

Figure 4.9  
Example of a roller shutter door installation

### 4.3.6 PBP and other development

Applications for developments that are not residential/rural residential subdivisions, SFPPs or residential infill should:

- note the range of available bush fire protection measures (in Chapter 3);
- satisfy the aim and objectives of PBP (see section 1.1);
- consider any matters listed for the specific purpose below; and
- propose an appropriate combination of bush fire protection measures, with evidence that the intent of each measure (with reference to the relevant Tables in sections 4.1.3 and 4.2.7) is satisfied.

For example, ensuring that a defensible space is provided, that proposed measures (in combination) minimise radiant heat levels, and that access and services are adequate.

The following discussion provides **specific advice** on some development types.

#### a) Dual occupancy

Key issues with dual occupancy are satisfaction of APZ (as with a single dwelling) and relative location/subdivision arrangements.

Where one building already exists and the second building can otherwise comply with APZ setbacks and appropriate construction levels, some attempt at retrofitting to ensure the integrity of the existing dwelling should also be made. This may be in the form of increased APZs (within the boundary of the development), ember proofing such as sarking under roofs, window screens, improved water availability, and suitable access.

In general, dual occupancy should be discouraged in isolated locations with poor access and inadequate water.

Where the erection of a dual occupancy is proposed, it is assumed that the proposal will be subdivided and as such will be assessed as if submitted under section 100B of the RF Act for a BFSA. A dual occupancy assessed under section 100B of the RF Act will not be required to be reassessed under section 79BA of the EP&A Act.

#### b) Strata subdivision of existing buildings

Some existing buildings are submitted for strata subdivision, to be managed under a body corporate. Where such developments are proposed, consideration should be made as to whether the strata arrangement will lead to increased densities (compared to current arrangement) and the vulnerability of the future residents. Emergency planning is critical and should be implemented prior to formal adoption of the strata arrangements. The existing building(s) conformity with APZs and construction standards should also be assessed. In cases where no

existing fire protection systems are evident or conformity with APZs is not proposed, property management plans as well as retrofitting for ember protection (screening and sarking) of exposed windows or roofs should be implemented.

Where there is any chance of deficiency in water supply or APZs then the suitability of the strata subdivision must be questioned unless supplementary water can be provided.

Where a Class 2 building has been assessed under section 79BA of the EP&A Act, a proposal for strata subdivision will not require a bush fire safety authority under section 100B of the RF Act.

#### c) Conversion of an existing building to a new use

Over time, developments catering for some uses may need to be upgraded, redeveloped or changed in line with movements in socio-economic or demographic factors. Where such changes result in significantly increased densities for residential uses or where new structures need to be erected, the provisions of this document should be addressed. This will include, but is not restricted to, construction standards, setbacks, water supply, and emergency planning.

The conversion of an existing building to a new use brings with it special considerations. An example is the conversion of warehousing to residential uses.

Where the conversion increases the density of vulnerable residents, added caution should apply. Such arrangements are generally unsuitable at the bushland interface and should not be encouraged. Nonetheless, the use of bush fire protection measures in combination will still apply.

#### d) Historic buildings

In relation to land identified as having heritage significance, the usual requirements for bush fire protection may conflict with the conservation of significant heritage fabric and its setting. Development affecting heritage places, which proposes the intensification of residential uses should be considered on an individual basis. The application of PBP is to be considered in the context of the conservation principles, processes and practices of the Illustrated Burra Charter (Australia ICOMOS, 2004)

#### e) State Environmental Planning Policy No. 15 (Rural Landsharing Communities)

These developments are often referred to as multiple occupancies. Multiple occupancy is defined as the "collective management and sharing of un-subdivided land, facilities and resources." This aims to encourage community based, environmentally sensitive approaches to rural settlement. In this type of development, for example, there may be a common dining area although each family unit has separate sleeping quarters.

Good access, fire management planning (for hazard reduction and internal response capability), provision of plentiful water supplies and overall emergency planning are crucial for such developments.

Because of the nature of the development and the overall community approach, such developments are encouraged to have the residents prepared for firefighting and to provide an easily accessible and highly resilient building, capable of being a refuge in the face of a bush fire event.

SEPP 15 developments may include dwellings which will not comply with the construction standards of AS 3959 - 1999. In recognition of the aims of such developments, but still maintaining the objectives of this document, at least one building within the development must comply with the setback distances in Appendix 3 for the associated construction standard. The provisions of this document relating to rural-residential development for a safe refuge should also apply to rural landsharing communities.

Where buildings are not clustered and do not provide mutual protection, each dwelling will need to comply with the appropriate setbacks and construction requirements (set out in AS 3959 - 1999). The performance requirements for eco-tourism (see page 39) apply to SEPP 15 type developments.

#### f) Buildings of Class 5 to 8 and 10 of the BCA

The definition of Class 5 – 8 and 10 buildings of the BCA can be found in Appendix 1. These classes of buildings include offices, factories, warehouses, public car parks and other commercial or industrial facilities.

The BCA does not provide for any bush fire specific performance requirements and as such AS 3959 does not apply as a set of 'deemed to satisfy' provisions. The general fire safety construction provisions are taken as acceptable solutions, but the aim and objectives of PBP apply in relation to other matters such as access, water and services, emergency planning and landscaping/vegetation management.

In circumstances where the aim and objectives of PBP (section 1.1) are not met, then the construction requirements for bush fire protection will need to be considered on a case-by-case basis.

In many instances, these types of developments will require on-site parking and loading areas. In such cases, it is prudent to place these facilities in the most appropriate location in order to establish defensible space for fire fighting purposes.

Class 10b buildings include a fence, mast, antenna, retaining or free-standing wall, swimming pool, or the like.

At the planning level, class 10b buildings in bush fire prone areas (e.g. fencing) should be non-combustible and where an above ground swimming pool is erected it should not adjoin or be attached directly onto a wall of a building of class 1-4 or SFPP Class 9.

Where a Class 10a building (e.g. shed) is constructed in proximity to another residential class of building the Class 10a should meet the requirements of that Class or be located >10 metres away from the main building.



*Class 10a buildings such as sheds should be located >10 metres from a building of another class unless they also comply with the relevant construction requirement of the main building under AS 3959 - 1999 and the BCA.*

# Appendices

## Appendix 1

### Key Legislation Relating to Bush Fire Prone Lands and Development Assessment

This legislation is current as at 1 December 2006. Check legislative provisions if in doubt. Proposed regulations commencing 1 March 2007 are also included.

#### A1.1 Section 79BA - *Environmental Planning and Assessment Act 1979*

##### 79BA Consultation and development consent—certain bush fire prone land

(1) Development consent cannot be granted for the carrying out of development for any purpose (other than a subdivision of land that could lawfully be used for residential or rural residential purposes or development for a special fire protection purpose) on bush fire prone land unless the consent authority:

- (a) is satisfied that the development conforms to the specifications and requirements of Planning for Bushfire Protection (2001) produced by the NSW RFS (or, if another document is prescribed by the regulations for the purposes of this paragraph, that document), that are relevant to the development, or
- (b) the consent authority has consulted with the Commissioner of the NSW RFS concerning measures to be taken with respect to the development to protect persons, property and the environment from danger that may arise from a bush fire.

(2) In this section: special fire protection purpose has the same meaning as it has in section 100B of the *Rural Fires Act 1997*.

#### A1.2 Section 146 - *Environmental Planning and Assessment Act 1979*

##### 146 Bush fire prone land

(1) If a bush fire risk management plan applies to land within the area of a council, the council must, within 12 months after the commencement of this section (and before the end of the period of every five years after the commencement):

- (a) request the Commissioner of the NSW RFS to designate land (if any) within the area that the Commissioner considers, having regard to the bush fire risk

management plan, to be bush fire prone land, and  
(b) must record any land so designated on a map.

(2) The Commissioner of the NSW RFS must, if satisfied that the land designated by the Commissioner has been recorded by the council on a map, certify the map as a bush fire prone land map for the area of the council.

(3) Land recorded for the time being as bush fire prone land on a bush fire prone land map for an area is bush fire prone land for the area for the purposes of this or any other Act.

(4) The bush fire prone land map for an area is to be available for public inspection during normal office hours for the council.

(5) In this section: bush fire risk management plan has the same meaning as it has in the *Rural Fires Act 1997*.

#### A1.3 Section 100B - *Rural Fires Act 1997* - Bush Fire Safety Authorities

(1) The Commissioner may issue a bush fire safety authority for:

- (a) a subdivision of bush fire prone land that could lawfully be used for residential or rural residential purposes, or
- (b) development of bush fire prone land for a special fire protection purpose.

(2) A bush fire safety authority authorises development for a purpose referred to in subsection (1) to the extent that it complies with standards regarding setbacks, provision of water supply and other matters considered by the Commissioner to be necessary to protect persons, property or the environment from danger that may arise from a bush fire.

(3) A person must obtain such a bush fire safety authority before developing bush fire prone land for a purpose referred to in subsection (1).

(4) Application for a bush fire safety authority is to be made to the Commissioner in accordance with the regulations.

(5) Development to which subsection (1) applies: (a) does not include the carrying out of internal alterations to any building,

# Appendices

- (a1) does not include the carrying out of any development excluded from the operation of this section by the regulations, and
- (b) is not complying development for the purposes of the *Environmental Planning and Assessment Act 1979*, despite any environmental planning instrument.

(6) In this section:

“special fire protection purpose” means the purpose of the following:

- (a) a school,
- (b) a child care centre,
- (c) a hospital (including a hospital for the mentally ill or mentally disordered),
- (d) a hotel, motel or other tourist accommodation,
- (e) a building wholly or principally used as a home or other establishment for mentally incapacitated persons,
- (f) housing for older people or people with disabilities within the meaning of State Environmental Planning Policy No 5—Housing for Older People or People with a Disability (now SEPP (Seniors Living))
- (g) a group home within the meaning of State Environmental Planning Policy No 9—Group Homes,
- (h) a retirement village,
- (i) any other purpose prescribed by the regulations.

## A1.4 Schedule 4 – EP&A Reg 11 - Bush fire prone land

The following information is required to be included within a planning certificate under section 149 of the EP&A Act:

“If any of the land is bush fire prone land (as defined in the Act), a statement that all or, as the case may be, some of the land is bush fire prone land.

If none of the land is bush fire prone land, a statement to that effect.”

## A1.5 Clause 46 - Rural Fires Regulation 2002 - Application for bush fire safety authority

**Clause 46(1) of the Rural Fires Regulation 2002, specifies the information requirements for consideration of a bush fire safety authority under section 100B of the RF Act.**

- (1) For the purposes of section 100B (4) of the Act, an application for a bush fire safety authority must be in writing and include the following:
  - (a) a description (including the address) of the property on which the development the subject of the application is to be carried out,
  - (b) a classification of the vegetation on and surrounding the property (out to a distance of 140 metres from the boundaries of the property) in accordance

with the system for classification of vegetation contained in *Planning for Bush Fire Protection*,

- (c) an assessment of the slope of the land on and surrounding the property (out to a distance of 100 metres from the boundaries of the property),
- (d) identification of any significant environmental features on the property,
- (e) the details of any threatened species, population or ecological community identified under the *Threatened Species Conservation Act 1995* that is known to the applicant to exist on the property,
- (f) the details and location of any Aboriginal relic (being a relic within the meaning of the *National Parks and Wildlife Act 1974*) or Aboriginal place (within the meaning of that Act) that is known to the applicant to be situated on the property,
- (g) a bush fire assessment for the proposed development (including the methodology used in the assessment) that addresses the following matters:
  - (i) the extent to which the development is to provide for setbacks, including APZs,
  - (ii) the siting and adequacy of water supplies for firefighting,
  - (iii) the capacity of public roads in the vicinity to handle increased volumes of traffic in the event of a bush fire emergency,
  - (iv) whether or not public roads in the vicinity that link with the fire trail network have two-way access,
  - (v) the adequacy of arrangements for access to and egress from the development site for the purposes of an emergency response,
  - (vi) the adequacy of bush fire maintenance plans and fire emergency procedures for the development site,
  - (vii) the construction standards to be used for building elements in the development,
  - (viii) the adequacy of sprinkler systems and other fire protection measures to be incorporated into the development,
- (h) an assessment of the extent to which the proposed development conforms with or deviates from the standards, specific objectives and performance criteria set out in Chapter 4 (Performance Based Controls) of *Planning for Bush Fire Protection*.

## A1.6 Clause 46A - Rural Fires Regulation 2002 - Development excluded from requirements for bush fire safety authority

- (1) For the purposes of section 100B (5) (a1) of the Act, the following development is excluded from the operation of that section:
  - (a) development for the purposes of licensed premises that do not provide overnight accommodation (other than for the owner or manager of the premises),

- (b) strata subdivision of a building, but only if development consent for the erection of the building was granted in accordance with section 79BA of the *Environmental Planning and Assessment Act 1979*,
- (c) strata subdivision of a class 2 building erected before 1 August 2002, but only if the building complies with the requirements of Level 1 construction under AS 3959-1999, *Construction in Bushfire Prone Areas*,
- (d) subdivision of land for the purposes of converting an existing dwelling to a dual occupancy, but only if development consent for the dwelling was granted in accordance with section 79BA of the *Environmental Planning and Assessment Act 1979*,
- (e) subdivision of land (including any boundary adjustments) that is leased under the *Western Lands Act 1901*,
- (f) subdivision for the purposes of consolidations of lots or boundary adjustments on land where the number of lots are reduced, but only if any existing dwelling on the land complies with the requirements of Appendix 3 (Site Bush Fire Attack Assessment) of *Planning for Bush Fire Protection*,
- (g) development for the purposes of bed and breakfast accommodation using an existing building, but only if the building is more than 30 metres from native vegetation,
- (h) subdivision of land used or proposed to be used for industrial purposes on which the erection of a dwelling related to the industrial use of the land (such as a manager's residence) is permitted,
- (i) subdivision of land for a rural residential purpose in a Western New South Wales district, but only if:
  - (i) no lot created by the subdivision is greater than 10 hectares, and
  - (ii) the bush fire prone land in any lot is less than 10 per cent of the lot, and
  - (iii) each lot has direct access to an existing public road.

(2) In this clause:

**class**, in relation to a building, means a building of the specified class under the *Building Code of Australia*.

**Building Code of Australia** has the same meaning as it has in the *Environmental Planning and Assessment Act 1979*.

**Western New South Wales district** means any of the following weather forecast districts referred to in Schedule 1:

- (a) Upper Western Weather Forecast District,
- (b) Lower Western Weather Forecast District,
- (c) Riverina Weather Forecast District,
- (d) South West Slopes Weather Forecast District,
- (e) Central West Plains Weather Forecast District,
- (f) Central West Slopes Weather Forecast District,
- (g) Central Tablelands Weather Forecast District,

- (h) North West Plains Weather Forecast District,
- (i) North West Slopes Weather Forecast District.

### **A1.7 Clause 46B - Rural Fires Regulation 2002 - Additional special fire protection purposes for which bush fire safety authority required**

For the purposes of paragraph (i) of the definition of **special fire protection purpose** in section 100B (6) of the Act, the following purposes are prescribed:

- (a) manufactured home estates (within the meaning of *State Environmental Planning Policy No 36—Manufactured Home Estates*), comprising two or more caravans or manufactured homes, used for the purpose of casual or permanent accommodation (but not tourist accommodation),
- (b) sheltered workshops, or other workplaces, established solely for the purpose of employing persons with disabilities,
- (c) respite care centres, or similar centres, that accommodate persons with a physical or mental disability or provide respite for carers of such persons,
- (d) student or staff accommodation associated with a school, university or other educational establishment.

### **A1.8 Classifications (of Buildings) – Volume 1, Building Code of Australia (2006)**

The Building Code of Australia is updated annually and classes of buildings should be confirmed within the latest version of the Code. Buildings are classified as being from Classes 1 to 10.

For the purposes of *Planning for Bush Fire Protection*, the descriptions of the various Classes within the document apply to the 2006 version of the Code.

Classes 1, 2, 3 and 4 are buildings primarily used as a residence.

Classes 5, 6, 7 and 8 are buildings used as shops, warehouses, factories, offices and carparks and the like.

Class 9 buildings include health care, assembly buildings and aged care buildings.

Class 10 buildings are non-habitable building such as a shed as well as fences, free standing walls and swimming pools.

Importantly, Class 3 (other than a detention centre) and Classes 9a and 9c buildings will be a special fire protection purpose for the purposes of section 100B of the *Rural Fires Act 1997*. Other classes of buildings can be assessed under the provisions of section 79BA of the *Environmental Planning and Assessment Act, 1979*.

## Appendix 2

### Determining Asset Protection Zones

#### A2.1 Introduction

This Appendix shows how APZs are determined for residential and rural-residential subdivision and new special fire protection purposes. This assessment will determine the minimum setbacks required for habitable buildings in residential purpose developments designated as bush fire prone.

#### A2.2 Terminology

The methodology requires consideration of the following matters, which contribute to bush fire behaviour and radiant heat models:

- (i) **Asset Protection Zone (setback)** distances provide for:
  - minimal separation for safe firefighting (access to fire front);
  - reduced radiant heat;
  - reduced influence of convection driven winds;
  - reduced ember viability thereby limiting the impact of ember attack; and
  - dispersal of smoke which would otherwise severely impact on residents affected by reduced mobility or health issues.
- (ii) **Predominant Vegetation** is classified by structure or formation using the system adopted by Keith (2004) and by the general description using Table A2.1. Vegetation types give rise to resultant radiant heat (assumed under unmanaged conditions to represent an extreme scenario as the danger period is the lifetime of any proposed development) and fire behaviour characteristics. There are 12 vegetation formations (with sub-formations) identified in PBP.
- (iii) **Effective Slopes** are classified within five slope classes, one being upslope and four being

downslope, ranging from flat to 18 degrees in steps of five degrees. This recognises the reduced rate of spread (ROS) inherent to fire travelling downslope and the restrictions imposed on development by slopes greater than 18 degrees. The effective slope is that slope within the hazard which most significantly affects fire behaviour of the site having regard to the vegetation class found.

(iv) **Fire weather** assessment assumes a credible worst case scenario and an absence of any other mitigating factors relating to aspect or prevailing winds. The 1:50 year fire weather scenario for most of the State was determined as FDI=80, however, a number of areas including the Greater Sydney, Greater Hunter, Illawarra, Far South Coast and Southern Ranges Fire Areas have higher FDIs which are set at 100. This is believed to occur with reasonable frequency in their respective fire areas. The relevant fire areas are set out in Table A2.3.

(v) **Fire intensity (I)** is determined following the formula adapted from Luke and McArthur (1978),  $I = HWr/36$  where H is the heat yield for vegetation, W is fuel load (t/Ha) and r is ROS (km/hr). ROS is normally determined using McArthur Meter Mark V at the relevant FDI for forests and woodlands. Other models are used for heaths and scrubs (Catchpole, et al, 1998). Radiant heat is then derived from flame length and intensity models using the 'view factor' model (Douglas and Tan, 2005).

(vi) **Inner Protection Area (IPA) and Outer Protection Area (OPA)** for forest and woodland vegetation. The IPA is critical to providing a defensible space and managing heat intensities at the building surface. The OPA serves to reduce the potential length of flames by slowing the ROS, filtering embers and reducing the likelihood of crown fire. The IPA may be increased at the expense of OPAs.

For other vegetation types (such as heaths,

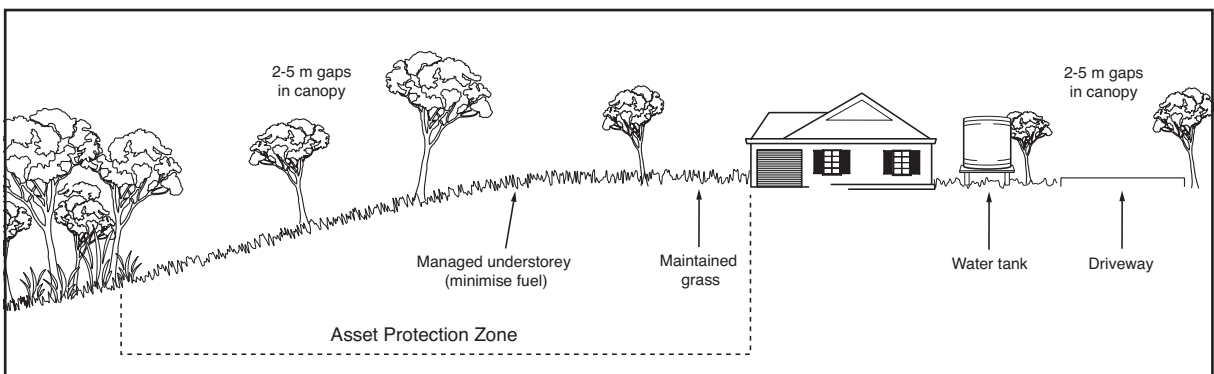

Figure A 2.1 Asset Protection Zone ( setback ) design

rainforests, arid shrublands and semi-arid woodlands), it is not feasible to distinguish between IPAs and OPAs and therefore all such APZs should be managed as IPAs.

An IPA should provide a tree canopy cover of less than 15% and should be located greater than 2 metres from any part of the roofline of a dwelling. Garden beds of flammable shrubs are not to be located under trees and should be no closer than 10 metres from an exposed window or door. Trees should have lower limbs removed up to a height of 2 metres above the ground.

An OPA should provide a tree canopy cover of less than 30% and should have understorey managed (mowed) to treat all shrubs and grasses on an annual basis in advance of the fire season (usually September).

### A2.3 Procedure

The following procedure is to be adopted when assessing a development at a defined precinct level in order to determine whether the development is bush fire prone and if so, which setbacks will be appropriate:

- (a) Determine vegetation formations, as follows:
  - (i) identify all vegetation in all directions from the site for a distance of 140 metres;
  - (ii) consult Table A2.1 to determine the predominant vegetation type; and
  - (iii) select the predominant vegetation formation as described in Table A2.1.
- (b) Determine the effective slope of the land under the Predominant Vegetation Class and the site (slope classes are detailed on page 56).
- (c) Determine the appropriate fire (weather) area in Table A2.3 and note the relevant FDI.
- (d) Consult Tables A2.4–2.7 and determine the appropriate setback for the assessed land use, vegetation group and slope range.

#### (a) Predominant Vegetation Class Formation

Determine the predominant vegetation communities using high resolution (within five

metres) vegetation databases and/or field assessment by qualified persons over a distance of at least 140 metres in all directions from the proposed property boundary or building footprint on the development site. Where a mix of vegetation types exist the type providing the greater hazard is said to predominate. Vegetations descriptions are as per Keith D. 2004 in: "Ocean Shores to Desert Dunes" published by DEC (except heathlands which is provided two sub-formations rather than one based largely on vegetation height). Consideration is to be given to the understorey as this may contain the greater mass of fuels. Do not include vegetation that is to be cleared as part of the development.

For the purposes of this document, vegetation is classified (using the formations and sub-formations within Keith (2004) (see Table A2.1) into:

- forests (wet sclerophyll forests and dry sclerophyll forests);
- woodlands;
- forested wetlands;
- tall heaths;
- freshwater wetlands
- short heaths;
- alpine complex;
- semi-arid woodlands;
- arid shrublands;
- rainforests; and
- grasslands.

Plantations not being native timber plantation (usually pines) are also assessed as being a bush fire hazard with a fuel load of 20t/Ha.

Where fuel loads are to be assessed, PBP has adopted a reliable system of assessing fuel accumulation rates based on canopy cover, years since last fire and shrub layer cover (Forestry Commission of NSW, 1991). This has also been validated with published literature on fuel loads (eg. Good, 1994, Watson, 2005, Cheney and Sullivan,

***PBP does not accept photo comparative assessment techniques as a basis of estimating fuel in forests for land use planning and construction purposes due to the significant variability in interpretation.***

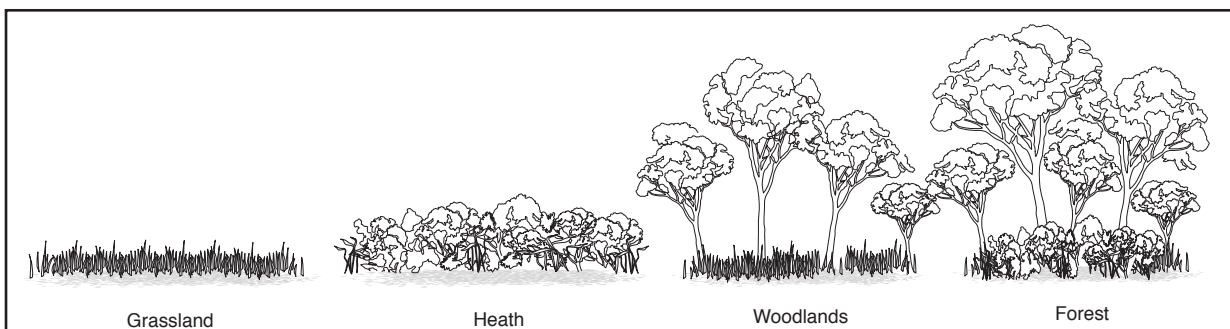
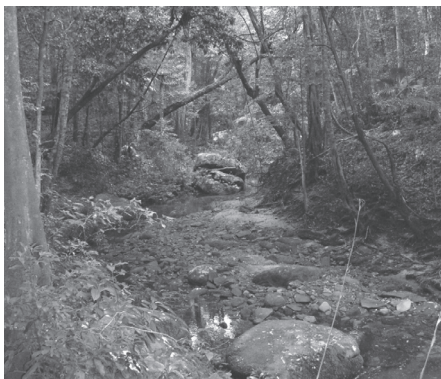
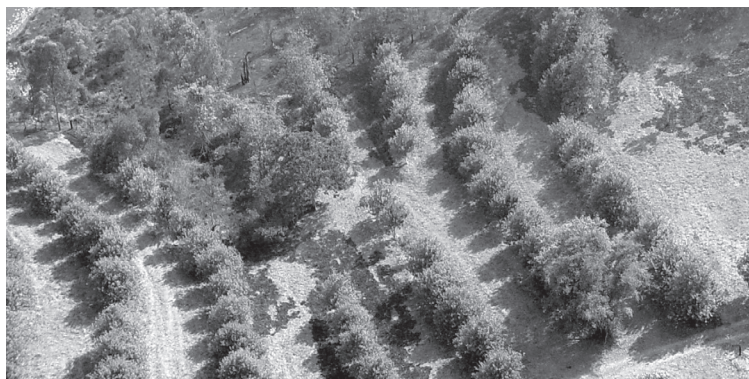

Figure A 2.2 Examples of Vegetation Types used in PBP



Riparian areas



Orchards (reduced vegetation)



Playgrounds (reduced vegetation)



Woodland remnant

Examples of non-vegetated and reduced vegetation areas.

1997, Department of Planning, 1984). For the purposes of assessing available fuel, the forest fuel is assumed to have accumulated over a period of 20 years and is the loading given for dry sclerophyll forests.

**Recent experiences from bush fires in Central Western NSW have demonstrated that a significant threat can exist for developments in grassland areas. Construction requirements are not specified in relation to grassland areas and these areas may not be mapped as being bush fire prone. Grass fires can threaten the sub floor spaces of a building and may generate significant embers. The RFS supports protection of the sub floor or the integration of 1.8 metre high protective (non combustibile) fencing in conjunction with screened windows and a basic APZ of 10 metres for these situations. LEP provisions should address rural properties at threat from crop or grass fires including access, water and the above as a requirement.**

Remnant vegetation is a parcel of vegetation with a size of less than 1 Ha or a shape that provides a potential fire run directly toward buildings not exceeding 50m. These remnants are considered

a low hazard and APZ setbacks and building construction standards for these will be the same as for rainforests. The effective slope is to be determined over the length of the remnant.

Although small remnants, coastal wetlands and riparian areas vary significantly in structure and composition, these areas have been generally assessed as being bush fire hazards, with the exception of saline wetlands that are assessed as being a non-hazard. Riparian areas are those areas of vegetation which are no greater than 20 metres in width and are found on either bank of a river, creek or stream identified on a bush fire prone land map, and are treated the same as rainforests.

**For the purposes of assessment, the following are not considered a hazard or as a predominant vegetation class/formation and can be included within an asset protection zone:**

- (a) non-vegetated areas including roads, footpaths, cycleways, waterways, buildings, rocky outcrops and the like; and**
- (b) reduced vegetation including maintained lawns, golf course fairways, playgrounds or sports fields, vineyards, orchards, cultivated ornamental gardens and commercial nurseries.**



**Rainforests (Closed forest)**



**Dry sclerophyll forests (Open forest)**



**Central Western Grasslands**



**Semi-arid woodlands (Low woodlands)**

*Examples of Vegetation Formations of NSW*

Table A2.1 Classification of Vegetation Formations (after Keith, 2004)

Keith (2004) Formations		
Formation class	Formation (Sub formation) Description	F (r)/F(t)* (t/ha)
<b>Rainforests (Closed forest)</b>	Closed and continuous tree canopy composed of relatively soft, horizontally-held leaves. Generally lacking in eucalypts. Understorey typically includes ferns and herbs. Vines often present in canopy or understorey. Occur mainly in areas that are reliably moist, mostly free of fire and have soils of moderate to high fertility. Typically coastal and escarpment locations.	8/10
<b>Wet sclerophyll forests (Tall open forest)</b>	High open tree canopy dominated by tall (typically >30m), straight-trunked eucalypt species. Luxuriant understorey composed of soft leaved shrubs, ferns and herbs. Many understorey plants are rainforest species. Found on moderately fertile soils in areas of high (>900mm) rainfall.	
	<b>Shrubby sub formation</b> Many soft-leaved shrubs and small trees in understorey. Eg. Typically sub-alpine and tableland locations.	25/30
	<b>Grassy sub formation</b> Fewer soft-leaved shrubs allowing a more substantial cover of grasses and herbs on the forest floor. Reflects drier habitat. Eg. Typically coastal and escarpment locations.	20/25
<b>Grassy woodlands (Woodlands)</b>	Dominated by an open to sparse layer of eucalypts (typically boxes and red gums) with the crowns rarely touching (ie <30% foliage cover). Typically 15-35m high (may be shorter at sub-alpine altitudes). Diverse ground cover of grasses and herbs. Long lived perennial tussock grasses form the structural matrix of the understorey. Shrubs are sparsely distributed. Found on fine textured soils of moderate to high fertility, principally on flat to undulating terrain. Rainfall 500-900mm Tablelands, western slopes, and low rainfall coastal lowlands.	10/15
<b>Grasslands</b>	Dominated by large perennial tussock grasses and the presence of broad-leaved herbs in the inter-tussock spaces. Lack of woody plants. Associated with fertile heavy clay soils on flat topography on in regions with low to moderate rainfall. Plants include grasses, daisies, legumes, geraniums, saltbushes and copperburrs.	6
<b>Dry sclerophyll forests (Open forest)</b>	Dominated by eucalypts 10-30m tall with crowns that touch or overlap (ie foliage cover of 20-50%). Prominent layer of hard-leaved shrubs. Infertile soils. Rainfall >500mm. Coast, tablelands and western slopes.	
	<b>Shrub/grass sub formation</b> Conspicuous presence of grasses in the understorey. Also have a significant shrub component, including a mixture of hard leaved and soft-leaved plants. Includes native timber plantations.	20/25
	<b>Shrubby sub formation</b> Understorey dominated by shrubs including waratahs, banksias, spider flowers, wattles, pea-flowers, gum trees, tea-trees, native fuschias, boronias and wax flowers. Sparse ground cover comprised mainly of hard-leaved sedges. Found on sandy infertile soils on exposed sites.	20/25
<b>Heathlands (Shrublands)</b>	Shrubby vegetation. Principal plant species include banksias, spider flowers, wattles, legumes, eucalypts, tea-trees, paper barks, sheoaks, grass trees, cord rushes and sedges. Grasses are scarce. Found on infertile soils and is dependant on fire. Not found in arid and semi arid locations.	

Table A2.1 Classification of Vegetation Formations (after Keith, 2004)

Formation class	Formation (Sub formation) Description	F (r)/F(t) * (t/ha)
<b>Heathlands (Shrublands)</b>	<b>Tall Heaths (Scrub)</b> Heathlands greater than 2 metres tall. Includes Hawkesbury Sandstone vegetation with scattered overstorey trees and predominantly healthy understorey and coastal heath. May include some mallee eucalypts in coastal locations.	25
	<b>Short Heath (Open Shrub)</b> Heathlands less than 2 meters in height. Often more open in canopy.	15
<b>Alpine complex (Sedgeland)</b>	Structural dominance by small-leaved shrubs, herbs and tussocky grasses. Seasonal dormancy and snow tolerance. A lack of trees.	17
<b>Freshwater wetlands</b>	Areas permanently or temporarily inundated either by standing or running water (swamps). Dominated by sedges, shrubs or herbs. Excludes wetlands dominated by trees and those with significant quantities of salt. Coast, tablelands, western slopes and plains.	15
<b>Forested wetlands</b>	Restricted to riverine corridors and floodplains subject to periodic inundation. Dominated by eucalypts, tea-trees and paperbarks or sheoaks. Distinguished by presence of hydrophytes, woody plants that can live in flooded environments eg. sedges, rushes, buttercups, knot weeds, lignum, ferns and grasses. Found generally low altitudes. Soils vary from peaty and semi-humic loam soils to mineral clays and sandy loams. Coast, tablelands, and inland.	15/20
<b>Saline wetlands</b>	Distinguished by an abundance of salt. Halophytes abundant. Eg mangrove swamps, salt marshes and seagrass meadows. Coast (tidal estuaries) and western plains (salt lakes).	-
<b>Semi-arid woodlands (Low woodlands)</b>	Widely spaced tree canopies, trees 5-20m tall. Dominance of sclerophyllous trees (box eucalypts, mallee eucalypts, sheoaks, wattles and cypress pines), drought resistant shrubs and ephemeral grasses and herbs. Rainfall 250-500mm/year. Western plains.	
	<b>Grassy sub formation</b> Occurs on floodplains. Understorey predominantly grassy, although chenopod shrubs may be common in some local areas. Can be distinguished from grassy woodlands by their more ephemeral ground cover and predominant trees and shrubs, all of which have inland distributions.	5/18
	<b>Shrubby sub formation</b> Occurs on more elevated areas or uplands. Shorter trees <15m and less cover of grasses than the grassy formation. Abundant drought resistant shrubs and variable grass cover. Eg. Mallee woodland	8
<b>Arid shrublands</b>	Dominated by drought-tolerant shrubs, including chenopods. Occur where the rainfall or local soil moisture is too low to support tree-dominated vegetation. Rainfall <500mm. Western plains.	
	<b>Chenopod sub formation (Low shrublands)</b> Dominated by low shrubs (mostly <1.5m tall) such as saltbushes, bluebushes and copperburrs. Ground cover of perennial tussock grass (never hummock grass). Found on lime-rich calcareous or saline soils.	9
	<b>Acacia sub formation (Tall shrublands)</b> Shrubs usually taller than 2m, dominated by various acacia species and other large shrubs. May have abundant hummock grass (spinifex) ground cover. Found on silica rich soils. Eg. Mulga shrubland	9

\* Fuel loads are expressed as fuels contributing to rates of spread [F(r)] and total fuel loads [F(t)] that contribute to intensity. Single figures denote same values for both based on bush fire behaviour models.

**(b) Effective Slope**

Assess the slope over a distance of at least 100m from the existing property boundary (for subdivision) or building footprint (for SFPP) on the development site towards the various vegetation communities constituting the hazard. In assessing the slope, it may be found that there are a variety of slopes covering different distances. Determine the gradient within the hazard (vegetation) which will most significantly influence the fire behaviour of the site having regard to vegetation class found.

Slope assessment may be derived from topographic maps displaying 10 metre contour intervals. Where land is being surveyed by a land surveyor, assessments should be based on a minimum of five metre contours.

The slope is determined in terms of the following classes, relative to the location of the hazard:

- (i) all upslope vegetation (considered 0°)
- (ii) >0 to 5° downslope vegetation
- (iii) >5 to 10° downslope vegetation
- (iv) >10 to 15° downslope vegetation
- (v) >15 to 18° downslope vegetation

APZ tables in this Appendix are provided for acceptable solutions with slopes of up to 18 degrees. Effective slopes to be assessed with hazards in excess of 18 degrees will require a detailed performance assessment

SLOPE COMPARISONS		
Ratio	Degrees	Percentage
1:1	45	100%
1:1.5	34	66%
1:2	26	50%
1:2.5	21	40%
1:3	18	33%
1:3.5	15	28%
1:4	14	25%
1:4.5	12	22%
1:5	11	20%
1:5.5	10	18%
1:6	9	16%
1:6.5	9	15%
1:7	8	14%
1:7.5	8	13%
1:8	7	12%
1:8.5	7	11%
1:9	6	11%
1:10	6	10%
1:11	5	9%
1:12	5	8%
1:13	4	8%
1:14	4	7%
1:15	4	7%
1:16	4	6%
1:17	3	6%
1:18	3	5.5%
1:19	3	5%
1:20	3	5%

Table A 2.2 Slope Comparisons

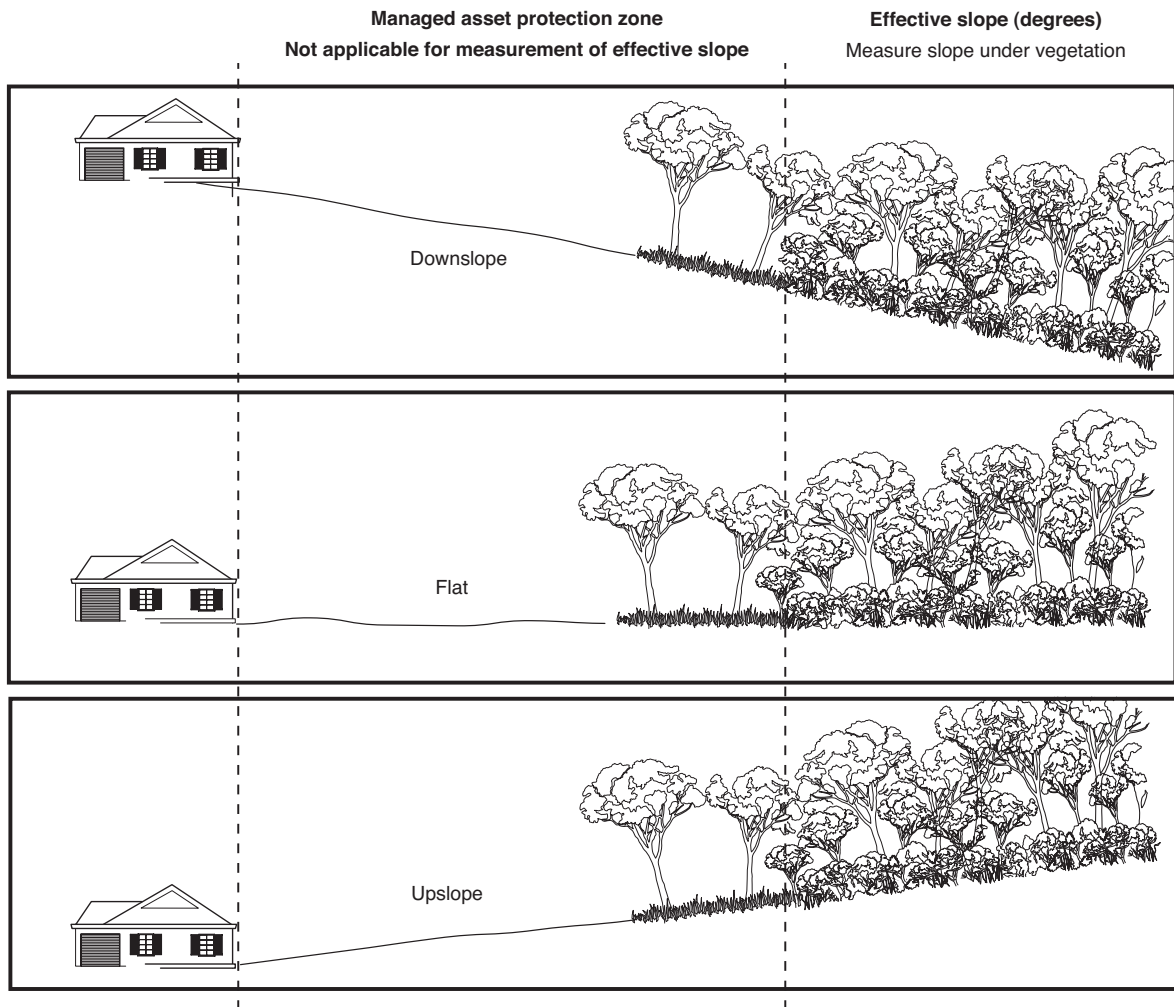

Figure A2.3 Determining Effective Slope

<p><b>1. FAR NORTH COAST (80)</b> Ballina Byron Clarence Valley Kyogle Lismore Richmond Valley Tweed</p> <p><b>2. NORTH COAST (80)</b> Bellingen Coffs Harbour Gloucester Great Lakes Greater Taree Hastings Kempsey Nambucca</p> <p><b>3. GREATER HUNTER (100)</b> Cessnock Dungog Lake Macquarie Maitland Muswellbrook Newcastle Port Stephens Singleton Upper Hunter</p> <p><b>4. GREATER SYDNEY REGION (100)</b> All Sydney Metropolitan Councils Plus Gosford, Blue Mountains, Hawkesbury and Wyong</p> <p><b>5. ILLAWARRA/SOALHAVEN (100)</b> Kiama Shellharbour Shoalhaven Wingecarribee Wollondilly Wollongong</p> <p><b>6. FAR SOUTH COAST (100)</b> Bega Valley Eurobodalla</p> <p><b>7. MONARO ALPINE (80)</b> Bombala Cooma Monaro Snowy River</p>	<p><b>8. ACT (N/A)</b> Australian Capital Territory</p> <p><b>9. SOUTHERN RANGES (100)</b> Palerang Goulburn Mulwaree Queanbeyan Upper Lachlan Yass Valley</p> <p><b>10. CENTRAL RANGES (80)</b> Bathurst Blayney Cabonne Cowra Lithgow Mid Western Regional Oberon Orange</p> <p><b>11. NEW ENGLAND (80)</b> Armidale Dumaresq Glen Innes Severn Guyra Tenterfield Uralla Walcha</p> <p><b>12. NORTHERN SLOPES (80)</b> Gunnedah Gwydir Inverell Liverpool Plains Tamworth Regional</p> <p><b>13. NORTH WESTERN (80)</b> Moree Plains Narrabri Walgett Warrumbungle</p> <p><b>14. UPPER CENTRAL WEST PLAINS (80)</b> Bogan Coonamble Gilgandra Warren</p> <p><b>15. LOWER CENTRAL WEST PLAINS (80)</b> Bland Dubbo Forbes Lachlan</p>	<p>Narromine Parkes Temora Weddin Wellington</p> <p><b>16. SOUTHERN SLOPES (80)</b> Boorowa Cootamundra Gundagai Harden Tumbarumba Tumut Young</p> <p><b>17. EASTERN RIVERINA (80)</b> Albury Coolamon Greater Hume Jonee Lockhart Wagga Wagga</p> <p><b>18. SOUTHERN RIVERINA (80)</b> Berrigan Conargo Corowa Deniliquin Jerilderie Murray Urana Wakool</p> <p><b>19. NORTHERN RIVERINA (80)</b> Carrathool Griffith Hay Leeton Murrumbidgee Narrandera</p> <p><b>20. SOUTH WESTERN (80)</b> Balranald Wentworth</p> <p><b>21. FAR WESTERN (80)</b> Bourke Brewarrina Broken Hill Central Darling Cobar Unincorporated NSW</p>
--	--	--

Table A2.3 NSW Fire Areas and associated council areas with appropriate FDI rating assumed as a 1:50 year event.

### (c) Determining Appropriate Fire (Weather) Areas

For residential and rural residential subdivisions locate the site in terms of the local council area (see inside rear cover and Table A2.3) where the development is to be located and determine the appropriate fire areas and corresponding FDI rating. For SFPP's see (d) below.

### (d) Determining Appropriate Asset Protection Zones (APZs)

Consult Tables A2.4 and A2.5 (for subdivisions) for each respective vegetation class and appropriate FDI rating. **These setbacks are based upon the need to conform to Level 3 (except grasslands) construction (AS 3959 – 1999) for a building of Class 1 or 2 under the BCA.**

Grasslands of 100 metres from any boundary (subdivision) or buildings (SFPPs) do not require construction requirements in conformity with AS 3959 – 1999 or this document but requires an APZ of 10 metres for slopes <18°.

If it is intended to construct to a lower bush fire protection standard (e.g. Level 1 or 2) or to no specific bush fire protection standards, Appendix 3 should be consulted for the appropriate setbacks for individual circumstances.

For SFPPs (e.g. SEPP – Seniors Living and Class 3 buildings), Table A2.6 is used. In interpreting the Tables refer to the accompanying notes to these Tables.

Location of APZs on slopes greater than 18 degrees is not supported for new developments on wooded vegetation, due to environmental constraints and difficulties in managing vegetation. In addition, vegetation could carry a canopy fire along these steep slopes where an understorey would otherwise normally be required to support a sustained crown fire.

APZs should be identified on plans for interface allotments by either a building line or building footprint. In some cases building envelopes are identified which include other building constraints. Unless otherwise specified, a building envelope will be taken as the building footprint.

Where the predominant vegetation is removed in establishing the required APZ, the site should be reassessed and the dimensions of the APZ may be adjusted in the light of the remaining predominant vegetation.

Allowable OPAs within an APZs are set out in Table A2.7 for forest vegetation.

**Table A2.4 Minimum Specifications for Asset Protection Zones (m) for Residential and Rural Residential Subdivision Purposes (for Class 1 and 2 buildings) in FDI 100 Fire Areas ( $\leq 29\text{kW}/\text{m}^2$ )**

Vegetation Formation	Effective Slopes				
	Upslope/Flat	>0°-5°	>5°-10°	>10°-15°	>15°-18°
Rainforests	10	10	15	20	25
Forests	20	25	35	50	60
Woodland (Grassy)	10	15	20	25	30
Plantations (Pine)	20	25	30	45	50
Tall Heath (Scrub)	15	15	20	20	20
Short Heath (Open Scrub)	10	10	10	15	15
Freshwater Wetlands	10	10	10	15	15
Forested Wetlands	15	20	25	35	45

**Table A2.5 Minimum Specifications for Asset Protection Zones (m) for Residential and Rural Residential Subdivision Purposes (for Class 1 and 2 buildings) in FDI 80 Fire Areas ( $\leq 29\text{kW}/\text{m}^2$ )**

Vegetation Formation	Effective Slopes				
	Upslope/Flat	>0°-5°	>5°-10°	>10°-15°	>15°-18°
Rainforests	10	10	15	15	20
Forests	20	20	30	40	45
Woodland	10	15	15	20	25
Plantations (Pine)	15	20	25	35	40
Tall Heath (Scrub)	15	15	20	20	20
Short Heath (Open Scrub)	10	10	10	15	15
Freshwater Wetlands	10	10	10	15	15
Forested Wetlands	15	20	20	30	35
Semi-Arid (Woodland)	10	10	10	10	15
Arid Shrubland	10	10	10	15	15

**Table A2.6 Minimum Specifications for Asset Protection Zones (m) for Special Fire Protection Purposes in bush fire prone areas ( $\leq 10\text{kW}/\text{m}^2$ )**

Vegetation Formation	Effective Slopes				
	Upslope/Flat	>0°-5°	>5°-10°	>10°-15°	>15°-18°
Rainforests	30	40	50	60	65
Forests	60	70	85	100	100
Woodland (Grassy)	40	50	60	70	75
Plantations (Pine)	50	60	70	85	95
Tall Heath (Scrub)	45	50	55	60	65
Short Heath (Open Scrub)	35	35	40	45	45
Freshwater Wetlands	35	35	40	45	45
Forested Wetlands	50	60	75	90	95
Semi-Arid (Woodland)	30	35	40	45	50
Arid Shrubland	30	35	40	45	45
Alpine Resorts	(see page 31 and Table A3.5 on page 66)				

**Table A2.7 Determining Allowable Outer Protection Areas (m) for forest vegetation within an APZ**

	Effective Slopes				
	Upslope/Flat	>0°-5°	>5°-10°	>10°-15°	>15°-18°
Forests FDI 100 - subdivision	10	10	15	25	30
Forests FDI 80 - subdivision	10	5	15	20	20
Forests SFPP	20	20	25	30	25

Note: Vegetation Formations based on Keith D. (2004) - see pages 54 - 55

*For Forest Vegetation Formations, APZs can incorporate IPAs and OPAs (see page 50). OPAs to the distances specified in Table A2.7 are allowable subject to meeting the performance requirements for the OPAs. The balance of the APZ is to be managed as an IPA.*

## Appendix 3

### Site Bush Fire Attack Assessment

#### A3.1 Introduction

*Within this appendix, words that are italicised are commentary and do not form part of the requirements for site assessment or the provision of a deemed-to-satisfy solution under the Building Code of Australia (BCA).*

This appendix sets out the site assessment methodology for NSW for determining the required level of construction from Section 3 of AS 3959 that applies to a building in a designated bush fire prone area.

This appendix replaces Section 2 of that Standard. This site assessment methodology forms part of the deemed-to-satisfy provisions of the Building Code of Australia (BCA) for NSW for construction in designated bushfire prone areas.

The term “designated bushfire prone area” is defined in the Building Code of Australia (BCA). NSW has varied the national BCA definition of this term. Refer to the relevant NSW variations in Volumes One and Two of the BCA.

#### A3.2 Application

This site assessment methodology applies to buildings to which the bush fire provisions of the BCA apply.

In NSW the BCA bush fire protection provisions are applied to (via a State variation to the BCA for NSW) Class 1, 2, 3 buildings, Class 4 parts of buildings and Class 9 buildings that are Special Fire Protection Purposes (SFPPs).

*The methodology in this appendix applies as follows:*

- *For new residential dwellings the methodology mirrors that in Appendix 2 for addressing APZ requirements. The assumption is that APZ and construction standards (and other measures) work together and, when subdividing land, the subsequent buildings can be built in accordance with AS 3959.*
- *For SFPPs the methodology should be addressed afresh. In other words, if a formal APZ currently does not exist, distances are to be measured from the boundary of the bush fire hazard to buildings (where the vegetation is maintained in a fuel free condition). An area is described as having a fuel free condition where the vegetation is maintained to the standard required in an APZ, as established in this document.*

- *Generally, no bush fire construction requirements apply to any proposed building located more than 100 metres away from a bush fire hazard.*

#### A3.3 Basis of the site assessment methodology: radiant heat flux and required separation distances

*There are a number of basic concepts underpinning the requirements of PBP. Each is briefly described below:*

##### (a) Radiant heat flux and fire intensity

*Fire intensity is the rate of heat release, per unit length of the fire front, measured in kilowatts per metre (kW/m). It is a function of the heat content and weight of the fuel and the rate of spread of the fire. Radiant heat flux is a measure of heat energy impacting on a surface (kW/m<sup>2</sup>).*

*Research has shown the effects of increasing radiant heat flux on buildings and people. This is shown in Figure A3.1*

##### (b) Fuel loads

*Fuel is any organic matter available for ignition and combustible components include leaves, twigs, bark and residue (J.Gould, 2003). Fuel load is a measure (tonnes per hectare) of the accumulated vegetative matter available to a resultant bush fire.*

*Determination of the protection measures required, is based on an estimation of the maximum hazard which, in turn, is based on maximum possible fuel loads likely to occur on and adjacent to the development site.*

##### (c) Flame zone

*The distance from a bush fire at which there is significant potential for sustained flame contact to a building. Flame length will vary (short/long) depending on wind and slope. Minimum defendable area and APZ requirements reflect flame length/zone calculations.*

##### (d) Determining appropriate hazard parameters

*A robust hazard assessment for habitable building development must quantify, for different vegetation types, the parameters of fire attack (embers, radiant heat, flame contact and wind) that damage or destroy buildings. This system must relate these parameters to threshold values of vulnerable components of buildings (CSIRO, 2000).*

Determining appropriate hazard parameters requires measurements or models to describe:

- components of structures, the threshold values for radiant heat flux and their duration;
- the flame characteristics of temperature, emissivity and hence radiant heat flux at the flame;
- different vegetation types, the flame height and width of flame-front and flame duration for high intensity bush fires as they reach the edge of vegetation; and
- the value for radiant heat flux as a function of distance from walls of flame of different dimensions. (see CSIRO, 2000)

In 2004, the RFS developed a model which related hazard parameters to various building components. This model has been used as a basis for developing the following methodology. Table A3.2 can and should be used for determining the likely level of bush fire attack on a building and hence which level of construction from AS 3959 is appropriate in the particular circumstances.

The methodology is based on radiant heat flux derived for 12 vegetation formations (10 sub-formations), six slope classes and appropriate regional weather conditions and applied to different construction standards.

At radiant heat flux levels under 12.5 kW/m<sup>2</sup>, unscreened windows may crack and allow heat and embers to enter the building leading to a building fire. At 19 kW/m<sup>2</sup> screened windows could fail. At levels of 29 kW/m<sup>2</sup> fascia board and flame retardant timbers are likely to ignite after a short period of exposure. Toughened glass is generally suitable up to levels of approximately 25 kW/m<sup>2</sup> and requires screening at levels above this. For building elements

subject to radiant heat levels of greater than 29 kW/m<sup>2</sup>, the use of exposed timber is not suitable without specific testing in accordance with suitable protocols.

The distances below can be considered on the basis of the various elements of a building when subject to heat, flames and ember attack. Extensive ember attack can occur beyond 100 metres ahead of a bush fire, however, distances are limited to a maximum of 100 metres for class 1, 2, 3 and Class 4 parts of buildings and Class 9 buildings that are SFPP.

Figure A3.1 and Table A3.1 summarise the relationship between radiant heat levels and required separation (APZ) distance

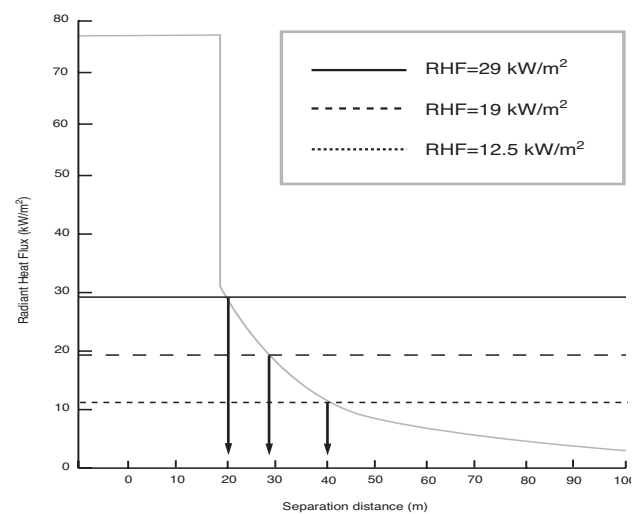

Figure A3.1 Sample radiation - distance graph of forests for FDI = 100 (0° slope)

Radiant Heat Flux	Likely Effects	Approx. distances
>29 – 110 kW/m <sup>2</sup>	Flame Zone	0 - 20 metres
29 kW/m <sup>2</sup>	Ignition of most timbers without piloted ignition (3 minutes exposure) (Level 3 construction) during the passage of a bush fire. Toughened glass could fail.	20 metres
19 kW/m <sup>2</sup>	Screened float glass could fail (Level 2 construction) during the passage of a bush fire.	27 metres
12.5 kW/m <sup>2</sup>	Standard float glass could fail (Level 1 construction) during the passage of a bush fire. Some timbers can ignite with prolonged exposure and with piloted ignition source (eg embers).	40 metres
10 kW/m <sup>2</sup>	Critical conditions. Firefighters not expected to operate in these conditions although they may be encountered. Considered to be life threatening < 1 minute in protective equipment. Fabrics inside a building could ignite spontaneously with long exposures.	45 metres
7 kW/m <sup>2</sup>	Likely fatal to unprotected person after exposure for several minutes	55 metres
4.7 kW/m <sup>2</sup>	Extreme conditions. Firefighter in protective clothing will feel pain. (60 seconds exposure)	70 metres
3 kW/m <sup>2</sup>	Hazardous conditions. Firefighters expected to operate for a short period (10 minutes)	100 metres
2.1 kW/m <sup>2</sup>	Unprotected person will suffer pain after 1 minute exposure - non fatal.	140 metres

Note: assumes flame temperature of 1090K for all scenarios.

Table A3.1 Radiant heat flux and effects on buildings and people for a modeled forest fire (FDI 100 on flat ground)

Five categories of bush fire attack and three construction standards are determined and described in Table A3.2 below.

Level 1 construction standards shall apply if the proposed building is located within the specified distances within Tables A.3.3, A3.4 and A3.5 for **Medium** Bush Fire Attack (in AS 3959).

Level 2 construction standards shall apply if the proposed building is located within the specified distances within Tables A.3.3, A3.4 and A3.5 for **High** Bush Fire Attack (in AS 3959).

Level 3 construction standards shall apply if the proposed building is located within the specified distances within Tables A.3.3, A3.4 and A3.5 for **Extreme** Bush Fire Attack (in AS 3959).

Performance based assessments will need to apply if the building exceeds the specification of Level 3 of AS 3959 (ie  $>29 \text{ kW/m}^2$ ) in which case it is considered to be within the 'Flame Zone'.

In general, a deemed-to-satisfy outcome can be achieved where the building is exposed to a radiant heat of less than  $29 \text{ kW/m}^2$  without flame contact. There is no deemed-to-satisfy for

construction in the **Flame Zone**. Applicants need to consider the Performance Requirements of the BCA and the Specific Objectives of PBP for the type of building constructed as well as A3.5 below.

*Construction should not proceed where the proposed building has been identified as being at unacceptable risk because of any of the following:*

- *flame impingement will result in insufficient defensible space to protect the structure. These areas are identified as being within the Flame Zone;*
- *there is no safe escape route for the building occupants and firefighters likely to be involved in protecting the building and its occupants during a bush fire.*

The level of construction cannot fall to less than Level 1 construction where any part of the building is closer than 100 metres to the source of bush fire attack (unless otherwise provided for).

An elevation is exposed if there is a direct line of sight from any part of that elevation to the source of the bush fire attack (excluding fencing and other minor obstructions).

PBP Category	Description	AS 3959 Construction Level
<b>Low</b>	Minimal attack from radiant heat and flame due to the distance of the site from the vegetation, although some attack by burning debris is possible. There is insufficient threat to warrant specific construction requirements.	Low - no construction requirements
<b>Medium</b>	Attack by burning debris is significant with radiant heat (not greater than $12.5 \text{ kW/m}^2$ ). Radiant heat is unlikely to threaten building elements (eg unscreened glass). Specific construction requirements for ember protection and accumulation of debris are warranted.	Medium - Level 1
<b>High</b>	Attack by burning debris is significant with radiant heat levels (not greater than $19 \text{ kW/m}^2$ ) threatening some building elements (screened glass). Specific construction requirements for embers and radiant heat are warranted.	High - Level 2
<b>Extreme</b>	Attack by burning debris is significant and radiant heat levels (not greater than $29 \text{ kW/m}^2$ ) threaten building integrity. Specific construction requirements for ember and higher radiant heat are warranted. Some flame contact is possible.	Extreme - Level 3
<b>Flame Zone</b>	Radiant heat levels and flame contact likely to significantly threaten building integrity and result in significant risk to residents who are unlikely to be adequately protected.	Outside Scope

Note: Attack from burning debris increases as the category of bush fire attack becomes more severe.

Table A3.2 Categories of bush fire attack and appropriate construction levels

The key to determining required level of construction is the category of bush fire attack. The following subsection describes how to determine these categories.

## A3.4 Site assessment methodology for determining level of bush fire attack

*This general method has been used to determine the categories of bush fire attack using NSW data. This provides a more refined bush fire attack site assessment.*

*The methodology was developed (see Douglas and Tan, 2005) from the following inputs:*

- *the relevant weather scenario for the fire weather district in NSW (see inside rear cover and Table A2.3)*
- *vegetation types and the corresponding fuel types present were determined (see Table A2.1)*
- *the appropriate fuel loads for the fuel types were used for input into fire behaviour models*
- *the fire-line intensity (kW/m) for a range of slope and distance combinations was calculated*
- *the sustained flame length was calculated and appropriate flame temperature applied (1090K)*
- *distance classes for radiant heat flux for 12.5 kW/m<sup>2</sup>, 19 kW/m<sup>2</sup> and 29 kW/m<sup>2</sup> were determined using the View Factor model*
- *based on the calculated fire behaviour, the level of bush fire attack (Levels 1, 2, and 3) corresponding to the relevant radiant heat flux on the proposed building was then determined. If the distance was less than the theoretical flame length then the application of AS 3959 construction levels are exceeded (i.e. Flame Zone). At distances greater than 100 metres no specific construction provisions are required for forests, woodlands and tall heaths. For arid shrublands, semi arid woodlands, rainforests and low heaths construction requirements may not be required at distances greater than 50 metres and in the case of rainforest 70 metres.*

*This procedure is based upon the generic method described above and uses the weather scenario of an appropriate Forest Fire Danger Index (FDI) (for forest fuels), wind speeds of 45kph and typical fuel loads for NSW vegetation experienced during a severe bush fire in NSW.*

To determine the required level of construction for a building the following steps must be followed:

**Step 1: Determine vegetation** formation types and sub-formations around the building (see Appendix 2), as follows:

- (i) Identify all the vegetation types within 140 metres of the site using Keith (2004); and
- (ii) Classify the vegetation formations as set out in Table A2.1 in Appendix 2.

*Note: Forests within Tables A3.3, A3.4 and A3.5 include wet sclerophyll, dry sclerophyll and pine plantation forests. Forest fuel loads are based on dry sclerophyll forest formations except for alpine forest.*

**Step 2: Determine the distance** between each vegetation formation identified (from the edge of the foliage cover) and the building.

**Step 3: Determine the effective slope** of the ground for each vegetation group (see Appendix 2) using the classes provided below. Slopes are classified as follows:

- (i) Upslopes are considered to be 0°.
- (ii) From 0° but not greater than 5°.
- (iii) Greater than 5° but not greater than 10°.
- (iv) Greater than 10° but not greater than 15°.
- (v) Greater than 15° but not greater than 18°.

**Step 4: Determine the relevant FDI** for the council area in which the development is to take place from Table A2.3 in Appendix 2. For Alpine Resorts see Step 5 below.

**Step 5: Match the relevant FDI, appropriate vegetation, distance and effective slope** classes to determine the category of bush fire attack applicable to the site.

- FDI 100 – Table A3.3 (page 63)
  - FDI 80 – Table A3.4 (page 64)
  - FDI 50 – Table A3.5 (page 65)
- apply the relevant attack category to each facade.

Note: A building with any facade identified as requiring a construction level must build all facades to at least Level 1, corresponding to Medium attack.

**Step 6: Determine the appropriate level of construction** found in Section 3 of AS3959 as identified within Table A3.3 to A3.5 below for each facade of the building. For the categories of bush fire attack determined for the site of the building there are five corresponding bush fire attack levels and three levels of bush fire construction with deemed-to-satisfy arrangements:

- (i) No specific construction requirements for the category of low bush fire attack;
- (ii) Level 1 construction for the category of medium bush fire attack;
- (iii) Level 2 construction for the category of high bush fire attack;
- (iv) Level 3 construction for the category of extreme bush fire attack;
- (v) Specific performance levels are unachievable for the category of Flame Zone.

Where more than one facade is exposed to a hazard, then the facade with the highest construction requirement is used to determine the appropriate level of construction. All other facades may be reduced by one level of construction unless that facade is also subject to the same category of bush fire attack.

Table A3.3 DETERMINATION OF CATEGORY OF BUSH FIRE ATTACK FDI 100  
(Greater Sydney, Greater Hunter, Illawarra/Shoalhaven, Southern Ranges, South Coast Fire (Weather) Areas) (see table A 2.3).

Vegetation Formation (class)	Categories of Bush Fire Attack (AS 3959-1999)				
	Flame Zone	Level 3 (Extreme)	Level 2 (High)	Level 1 (Medium)	No requirement
	Distance (m) of the site from the predominant vegetation class				
All upslopes and flat land (0 degrees)					
Forests (wet and dry sclerophyll)	<20	20-<29	29-<40	40 - 100	>100
Woodlands	<11	11-<16	16-<23	23 - 100	>100
Tall heath	<13	13-<19	19-<27	27 - 100	>100
Short heath	<9	9-<13	13-<19	19 - 50	>50
Forested wetlands	<16	16-<23	23-<32	32 - 50	>100
Freshwater wetlands	<9	9-<13	13-<19	19 - 50	>50
Rainforest	<9	9-<13	13-<19	19 - 50	>50
Downslope > 0 to 5 degrees					
Forests (wet and dry sclerophyll)	<25	25-<36	36-<49	49 - 100	>100
Woodlands	<14	14-<20	20-<29	29 - 100	>100
Tall heath	<15	15-<22	22-<31	31 - 100	>100
Short heath	<10	10-<15	15-<22	22 - 50	>50
Forested wetlands	<20	20-<29	29-<40	40 - 100	>100
Freshwater wetlands	<10	10-<15	15-<22	22 - 50	>50
Rainforest	<10	10-<16	16-<24	24 - 50	>50
Downslope > 5 to 10 degrees					
Forests (wet and dry sclerophyll)	<34	34-<45	45-<59	59 - 100	>100
Woodlands	<18	18-<26	26-<37	37 - 100	>100
Tall heath	<17	17-<24	24-<35	35 - 100	>100
Short heath	<10	10-<17	17-<25	25 - 50	>50
Forested wetlands	<25	25-<36	36-<49	49 - 100	>100
Freshwater wetlands	<10	10-<17	17-<25	25 - 50	>50
Rainforest	<14	14-<21	21-<31	31 - 50	>50
Downslope > 10 to 15 degrees					
Forests (wet and dry sclerophyll)	<47	47-<55	55-<71	71 - 100	>100
Woodlands	<24	24-<33	33-<46	46 - 100	>100
Tall heath	<19	19-<28	28-<39	39 - 100	>100
Short heath	<13	13-<19	19-<28	28 - 50	>50
Forested wetlands	<35	35-<45	45-<60	60 - 100	>100
Freshwater wetlands	<13	13-<19	19-<28	28 - 50	>50
Rainforest	<19	19-<28	28-<39	39 - 60	>60
Downslope > 15 to 18 degrees					
Forests (wet and dry sclerophyll)	<57	57-<62	62-<80	80 - 100	>100
Woodlands	<29	29-<38	38-<52	52 - 100	>100
Tall heath	<20	20-<30	30-<41	41 - 100	>100
Short heath	<14	14-<21	21-<30	30 - 50	>50
Forested wetlands	<43	43-<51	51-<67	67 - 100	>100
Freshwater wetlands	<14	14-<21	21-<30	30 - 50	>50
Rainforest	<23	23-<32	32-<44	44 - 70	>70

Note: "Forests" refers to wet sclerophyll forest, dry sclerophyll forest and plantation forest (including pine plantations).

# Appendices

Table A 3.4 DETERMINATION OF CATEGORY OF BUSH FIRE ATTACK FDI 80

Vegetation Formation (class)	Categories of Bush Fire Attack (AS 3959-1999)				
	Flame Zone	Level 3 (Extreme)	Level 2 (High)	Level 1 (Medium)	No requirement
	Distance (m) of the site from the predominant vegetation class				
All upslopes and flat land (0 degrees)					
Forests (wet and dry sclerophyll)	<17	17-<25	25-<35	35 - 100	>100
Woodlands	<9	9-<14	14-<20	20 - 100	>100
Tall heath	<13	13-<19	19-<27	27 - 100	>100
Short heath	<9	9-<13	13-<19	19 - 50	>50
Low woodland (semi-arid)	<7	7-<10	10-<15	15 - 50	>50
Arid shrublands	<8	8-<12	12-<18	18 - 50	>50
Forested wetlands	<13	13-<19	19-<28	28 - 50	>100
Freshwater wetlands	<9	9-<13	13-<19	19 - 50	>50
Rainforest	<7	7-<11	11-<16	16 - 50	>50
Downslope > 0 to 5 degrees					
Forests (wet and dry sclerophyll)	<22	22-<31	31-<42	42 - 100	>100
Woodlands	<12	12-<17	17-<25	25 - 100	>100
Tall heath	<15	15-<22	22-<31	31 - 100	>100
Short heath	<10	10-<15	15-<22	22 - 50	>50
Low woodland (semi-arid)	<8	8-<11	11-<17	17 - 50	>50
Arid shrublands	<9	9-<14	14-<21	21 - 50	>50
Forested wetlands	<17	17-<24	24-<34	34 - 100	>100
Freshwater wetlands	<10	10-<15	15-<22	22 - 50	>50
Rainforest	<9	9-<14	14-<20	20 - 50	>50
Downslope > 5 to 10 degrees					
Forests (wet and dry sclerophyll)	<28	28-<38	38-<52	52 - 100	>100
Woodlands	<15	15-<22	22-<32	32 - 100	>100
Tall heath	<17	17-<24	24-<35	35 - 100	>100
Short heath	<10	10-<17	17-<25	25 - 50	>50
Low woodland (semi-arid)	<9	9-<14	14-<20	20 - 50	>50
Arid shrublands	<10	10-<16	16-<24	24 - 50	>50
Forested wetlands	<20	20-<31	31-<42	42 - 100	>100
Freshwater wetlands	<10	10-<17	17-<25	25 - 50	>50
Rainforest	<12	12-<18	18-<26	26 - 50	>50
Downslope > 10 to 15 degrees					
Forests (wet and dry sclerophyll)	<38	38-<47	47-<63	63 - 100	>100
Woodlands	<19	19-<28	28-<40	40 - 100	>100
Tall heath	<19	19-<28	28-<39	39 - 100	>100
Short heath	<13	13-<19	19-<28	28 - 50	>50
Low woodland (semi-arid)	<10	10-<17	17-<25	25 - 50	>50
Arid shrublands	<12	12-<18	18-<27	27 - 50	>50
Forested wetlands	<29	29-<39	39-<52	52 - 100	>100
Freshwater wetlands	<13	13-<19	19-<28	28 - 50	>50
Rainforest	<15	15-<23	23-<33	33 - 50	>50
Downslope > 15 to 18 degrees					
Forests (wet and dry sclerophyll)	<45	45-<54	54-<70	70 - 100	>100
Woodlands	<23	23-<33	33-<45	45 - 100	>100
Tall heath	<20	20-<30	30-<41	41 - 100	>100
Short heath	<14	14-<21	21-<30	30 - 50	>50
Low woodland (semi-arid)	<13	13-<20	20-<29	29 - 100	>100
Arid shrublands	<13	13-<20	20-<29	29 - 50	>50
Forested wetlands	<35	35-<44	44-<59	59 - 100	>100
Freshwater wetlands	<14	14-<21	21-<30	30 - 50	>50
Rainforest	<19	19-<27	27-<38	38 - 50	>50

Note: "Forests" refers to wet sclerophyll forest, dry sclerophyll forest and plantation forest (including pine plantations). This table applies to the Fire Areas not covered in Table A 3.3 or Table A 3.5.

Table A 3.5 DETERMINATION OF CATEGORY OF BUSH FIRE ATTACK FDI 50 (Alpine Resorts)

Vegetation Formation (class)	Categories of Bush Fire Attack (AS 3959-1999)				
	Flame Zone	Level 3 (Extreme)	Level 2 (High)	Level 1 (Medium)	No requirement
	Distance (m) of the site from the predominant vegetation class				
All upslopes and flat land (0 degrees)					
Forests	<15	15-<22	22-<31	31 - 100	>100
Woodlands	<7	7-<10	10-<15	15 - 100	>100
Tall heath	<13	13-<19	19-<27	27 - 100	>100
Short heath	<9	9-<13	13-<19	19 - 50	>50
Alpine Complex	<9	9-<14	14-<20	20 - 50	>50
Downslope > 0 to 5 degrees					
Forests	<18	18-<27	27-<37	37 - 100	>100
Woodlands	<8	8-<12	12-<18	18 - 100	>100
Tall heath	<15	15-<22	22-<31	31 - 100	>100
Short heath	<10	10-<15	15-<22	22 - 50	>50
Alpine Complex	<10	10-<16	16-<23	23 - 50	>50
Downslope > 5 to 10 degrees					
Forests	<23	23-<33	33-<45	45 - 100	>100
Woodlands	<10	10-<15	15-<23	23 - 100	>100
Tall heath	<17	17-<24	24-<35	35 - 100	>100
Short heath	<10	10-<17	17-<25	25 - 50	>50
Alpine Complex	<12	12-<18	18-<26	26 - 50	>50
Downslope > 10 to 15 degrees					
Forests	<31	31-<41	41-<55	55 - 100	>100
Woodlands	<13	13-<20	20-<29	29 - 100	>100
Tall heath	<19	19-<28	28-<39	39 - 100	>100
Short heath	<13	13-<19	19-<28	28 - 50	>50
Alpine Complex	<13	13-<20	20-<29	29 - 50	>50
Downslope > 15 to 18 degrees					
Forests	<37	37-<46	46-<61	61 - 100	>100
Woodlands	<15	15-<23	23-<33	33 - 100	>100
Tall heath	<20	20-<30	30-<41	41 - 100	>100
Short heath	<14	14-<21	21-<30	30 - 50	>50
Alpine Complex	<15	15-<22	22-<31	31 - 50	>50

Note: This table covers the NSW Alpine resort areas of:

- The Perisher Range – Perisher, Smiggin Holes, Blue Cow and Guthega.
- Thredbo Alpine Village
- Charlottes Pass
- Mount Selwyn
- Ski Rider
- Kosciuszko Mountain Retreat
- Sponars Chalet
- Bullocks Flat

Forests are based on forest types found.

## **A3.5 Construction Considerations within the Flame Zone**

*Buildings constructed within the flame zone are likely to be exposed to direct flame impingement from the fire front. The severity of this exposure is dependent upon the severity of the fire and separation of vegetation from the building, gradient and wind direction. The period of exposure to direct flame impingement from the fire front is dependent on distance from the bushland and can range from less than 3 minutes to sustained flame contact from heavy fuels of up to 20 minutes or more.*

*There is potential for the flame impingement to ignite the external façade of a building which can continue to burn after the passage of the fire front. Therefore some degree of conservatism in relation to the exposure period is appropriate. It is for this reason that the provisions of AS 3959 alone are not adopted within the category of attack Flame Zone in NSW.*

*There are no deemed-to-satisfy arrangements for construction of buildings within the Flame Zone. Where flame contact is likely, the radiant heat and convective heat exposures are considerable and overwhelms most materials.*

*While AS 3959 can be used as a guide to improve building safety, this is subject to additional control measures not included in this document. The design and construction of a building is just one means of mitigating the bush fire risk and will normally require supplementation by a range of other mitigation measures to the satisfaction of the council. Installation of hose reels, sprinkler systems and additional water supplies may be needed.*

*The extent of additional measures required will be dependent upon the bush fire hazard and its proximity. In addition to the construction requirement of AS 3959, applicants should also address the Performance Requirements of the BCA and consider the siting and the design principles in Section 4.3.5.*

*Where new testing regimes are developed, these should be incorporated as part of the process of developing alternative solutions for flame zone conditions (and other levels of bush fire attack). These alternative solutions will be considered on their merits and could form important developments in the area of bush fire safety for buildings.*



## Appendix 4

# Submission Requirements for DAs on bush fire prone land

### A4.1 For general development applications to be considered under section 79BA of the EP&A Act

Development applications on bush fire prone land must be accompanied by a Bush Fire Assessment Report within the Statement of Environmental Effects demonstrating compliance with the aim and objectives of PBP and the specific objectives and performance criteria for the land use proposed. In particular, the following matters must be addressed.

- i. a statement that the site is bush fire prone land, where applicable,
- ii. the location, extent and vegetation formation of any bushland on or within 100 metres of the site,
- iii. the slope and aspect of the site and of any bush fire prone land within 100 metres of the site, which may determine the likely path of any bush fires,
- iv. any features on or adjoining the site that may mitigate the impact of a high intensity bush fire on the proposed development, and
- v. a statement assessing the likely environmental impact of any proposed bush fire protection measures.
- vi. whether any building is capable of complying with AS 3959/1999 in relation to the construction level for bush fire protection.

For most smaller applications this can be done relatively simply and can be accompanied by a diagram showing the required features with approximate distances. The RFS has also produced guidelines for lodging of information for single dwellings. These can be downloaded from the RFS website at [www.rfs.nsw.gov.au](http://www.rfs.nsw.gov.au).

### A4.2 For integrated development applications under section 100B of the RF Act and section 91 of the EP&A Act

The detailed information to be contained within a Bush Fire Assessment Report submitted to the RFS under Clause 46 of the RF Reg is:

- a description of the property
  - provide Lot No., DP of subject land
  - street address with locality map
- zoning of subject land and any adjoining lands
- staging issues, if relevant, and description of the whole proposal;
- aerial or ground photographs of subject land including contours and existing and proposed cadastre .
- the classification of vegetation out to 140 metres from the development
  - provide a structural description consistent with the identification key in Keith D (2004) and PBP.
  - identify any past disturbance factors and any future intended land uses that could alter the vegetation classification in the future.
- an assessment of the effective slope to a distance of 100 metres
  - usually 5m contours will suffice for subdivisions, 10 metres should be used only if there has not been a survey undertaken by a registered land surveyor.
  - the effective slope is the slope under the vegetation assessed as being a hazard in relation to the development and not the slope within the asset protection zone.
- identification of any significant environmental features - these could include the presence of:
  - riparian corridors
  - SEPP 14 – Coastal Wetlands
  - SEPP 26 Littoral rainforests
  - SEPP 44 – Koala Habitat
  - areas of geological interest
  - environmental protection zones or steep lands (>18°)
  - land slip or flood prone areas
  - national parks estate or various other reserves.
- details of threatened species, populations, endangered ecological communities and critical habitat known to the applicant
  - details of some threatened species can be found on the web ([www.environment.nsw.gov.au](http://www.environment.nsw.gov.au))
  - past studies or surveys for the area (eg local environment studies)
  - documentation supplied to council in relation to flora and fauna
- details of Aboriginal heritage known to the applicant
  - past surveys and information held by the DEC. (application fees may apply)

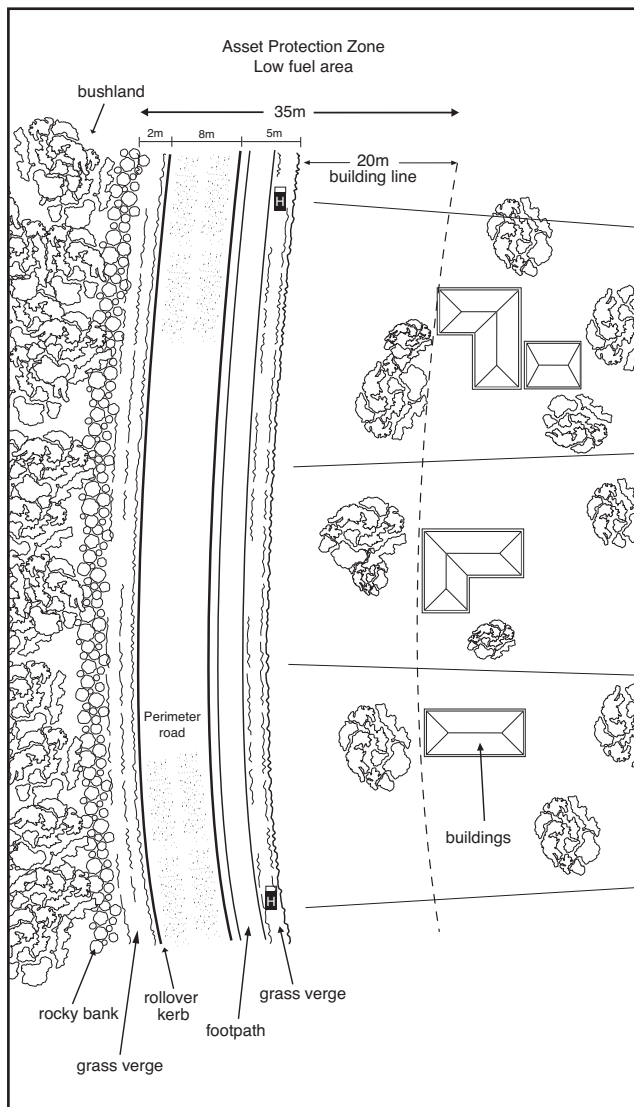

Figure A 4.1 Example of information supplied on a plan with a bush fire threat assessment.

*The RFS has also produced guidelines for lodging of information for simple subdivision (e.g. one lot into two lots). These can be downloaded from the RFS website at [www.rfs.nsw.gov.au](http://www.rfs.nsw.gov.au).*

- a bush fire assessment that addresses –
  - asset protection zones (including any management arrangements, any easements including those contained on adjoining lands)
  - siting and adequacy of water (in relation to reticulation rates or where dedicated water storage will be required)
  - capacity of public roads (especially perimeter roads and traffic management treatments)
  - whether public roads link to fire trails and have two way access
  - adequacy of access and egress
  - adequacy of maintenance plans (eg landscaping) and emergency procedures (especially SFPP developments)
  - construction standards to be used (where non-conformity to the deemed-to-satisfy arrangement is envisaged, which aspects are not intended to conform)
  - adequacy of sprinkler systems (only as an adjunct to other passive controls).
- an assessment of how the development complies with the acceptable solutions, performance requirements and relevant specific objectives within Chapter 4 of PBP.

APZs should be identified on plans for interface allotments by either a building line or building footprint. In some cases building envelopes are identified which include other building constraints. Unless otherwise specified, a building envelope will be taken as the building footprint. Where an applicant proposes not to follow the acceptable solutions for particular bush fire protection measures, detailed evidence must be provided demonstrating compliance with performance criteria and intent of the measures proposed. For alternate solutions under the BCA, the applicant must demonstrate how the product, design or material can meet the performance requirements of the BCA (see clause AO.8 in Volume 1 of the BCA).

*In relation to significant environmental features, threatened species, endangered populations, endangered ecological communities and Aboriginal heritage issues, the RFS only requires sufficient information to ascertain that the environmental values are or are not a constraint to development. The RFS is not providing an approval in relation to the loss or removal of these environmental assets. That is the role of the relevant consent authority.*

## Appendix 5

# Bush Fire Provisions - Landscaping and Property Maintenance

### A5.1 Introduction

Bush fires are a natural and periodic event in the Australian landscape. Many Australian plants and animals have adapted to fire over thousands of years and require fire as part of their life cycle.

However, development adjacent to bushland areas has increased the risk of fire impacting on people and their assets. Fire management needs to strike a balance between the protection of life and property and the maintenance of ecological processes and systems.

In Australia, bush fires are inevitable and an essential aspect of the landscape.

However, the impact on property and life can be reduced with responsible preparation and management of bush fire hazards. This is the responsibility of all land managers, as well as communities and individuals taking responsibility for their own fire safety.

The level of protection for life or whether or not a house or other assets survive a bush fire ultimately depends on the landowner and their level of preparedness against bush fire attack.

The planning system can be used to better effect in protecting human life, property and environmental values from the impacts of bush fire events.

In some cases this will involve land use planning and development controls, construction standards, APZs and subdivision layout, siting, design and provision of services. It also involves careful and deliberate consideration of the environmental impacts of these and how we can recognise the need to protect our wetlands, rainforests, koala habitat and other biodiversity and cultural values.

However, the best planning can be undone by poor maintenance and lack of forethought when landscaping a development. Therefore house survival ultimately depends on the householder.

Some maintenance also depends upon adjoining neighbours and upon fuel management in adjacent bush land areas by the owners, occupiers or managers of that land. General housekeeping and maintenance of the grounds by the householder is equally important and, in some cases, may even be more so.

Experience from the Canberra 2003 fires suggests that house losses are greatest in the area up to 250 metres from the bush interface. Distances of

less than 100 metres are particularly vulnerable to flame contact, radiant heat and ember attack.

Hence it is within this distance that efforts should be made to prepare for the onslaught of major bush fire events.

While other legislation provides the impetus for planning objectives, the RF Act provides the legislative vehicle to achieve bush fire management objectives.

In this appendix consideration will be given to the principles for landscaping and management, and the role of property maintenance during the fire event.

### A5.2 Principles of Protection

Bush fire attack takes essentially five forms;

- wind,
- smoke,
- ember,
- radiant heat and
- flame.

Evidence indicates ember attack is responsible for most bush fire related house fires. Strong winds resulting from severe bush fires will drive embers into vulnerable areas of a building, preheat and dry fuel ahead of a fire, lift roofing and extend flames along a more horizontal plane closer to building elements. Embers can also cause spotting in advance of the bush fire and provide piloted ignition to building elements. To effectively protect a building, strategies must be implemented that separate it from the hazard and reduce the intensity of bush fires to minimise the combined impact of ember, wind, flame and heat attack.

While smoke will cause minimal damage to property, it can severely affect the health of residents. Smoke is a significant factor in areas in which aged or disabled persons reside – hospitals and nursing homes - and more so where residents are susceptible to respiratory disorders.

Radiant heat (measured in kW/m<sup>2</sup>) can severely impair firefighting operations, the health of residents and the integrity of building elements. Radiant heat in excess of 10kW/m<sup>2</sup> can prevent emergency services personnel assisting residents of SFPP developments.

Flame attack will severely restrict firefighting operations, provide piloted ignition to building elements and threaten the health of residents and their capacity to evacuate the area.

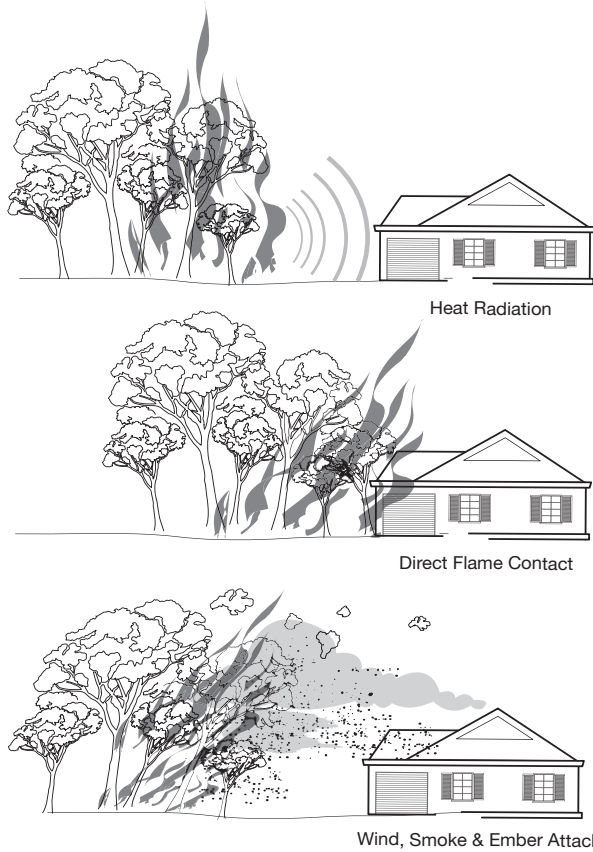

Figure A 5.1 Bush Fire Attack Mechanisms

Overall the intention of bush fire protection measures should be to prevent flame contact to a structure, reduce radiant heat to below the ignition thresholds for various elements of a building, to minimise the potential for wind driven embers to cause ignition and reduce the effects of smoke on residents and firefighters.

### A5.3 Principles of Landscaping Properties for Bush Fire Protection

The principles of landscaping for bush fire protection aim to:

- Prevent flame impingement on the dwelling;
- Provide a defensible space for property protection;
- Reduce fire spread;
- Deflect and filter embers;
- Provide shelter from radiant heat; and
- Reduce wind speed.

#### (a) Vegetation choices

All vegetative material can burn under the influence of bush fire.

With this in mind, careful attention must be paid to species selection, their location relative to their flammability, avoidance of continuity of vegetation (horizontally and vertically), and ongoing maintenance to readily remove flammable fuels (leaf litter, twigs and debris).

In the paper “*Landscape and Building Design for Bushfire Areas*” G.C. Ramsay and L. Rudolph have provided 14 attributes of vegetation which affect bush fire attack. In summary these attributes are:

- Moisture content of leaves;
- Volatile oil content of leaves;
- Mineral content of leaves;
- Leaf fineness;
- Density of foliage;
- Continuity of plant form;
- Height of lowest foliage above ground;
- Size of plant;
- Dead foliage on the plant;
- Bark texture;
- Quantity of ground fuels;
- Fineness of ground fuels;
- Compaction ability of ground fuels; and
- Mineral content of ground fuel.

What is clear is that the higher moisture content of leaves (mesic), the less bark that will be available and the lower the leaf drop, all of which will assist with maintenance of the understorey and will also assist in reducing bush fire attack.

Work in the USA and elsewhere has also suggested that in addition to removal of understorey species, the trimming of lower limbs of trees also assists in reducing fire penetration into the canopy. Trees such as ‘pencil pines’ and African olive have been attributed with high fire propagation due to the high fine fuel and/or oil content captured within the canopy. This leads to significant flame height. Avoid such species in favour of rainforest species such as Figs and Syzygium.

When choosing plants, be sure not to introduce weed species into an area. Fire events may provide the opportunity for weed species to spread and may contribute fuel to an area of otherwise lower fuel loads.

Contact local councils, plant nurseries and plant societies to determine suitable species for your area.

#### (b) Trees as Windbreaks

The use of trees as windbreaks is a common practice but trees also provide a useful function, trapping embers and flying debris, which would otherwise reach the house. The tree crown will rarely carry fire unless there is a significant fuel loading on the ground.

By reducing the wind speed, a row of trees also slows the rate of spread of a bush fire and a dense foliage traps radiant heat, lowering bush fire radiant heat.

Because of the effect of turbulence, a balance has to be struck between a high density of trees (that

maximises the trapping of embers and radiant heat but also maximises turbulence) and a lower density (that allows more embers and radiant heat to pass through but minimises turbulence). A windbreak that allows 30–60% of the wind to pass through is ideal as less than this becomes too solid with ember laden winds being carried over the top of the break.

To be effective a windbreak must:

- be located on the side of the lot from which fire weather normally approaches;
- be of sufficient length (generally 100 metres minimum length);
- be located at a distance of one to three times the height of fully grown trees but not within the IPA;
- use smooth barked eucalypts, rainforest trees or deciduous trees;
- make sure there are no breaks of sufficient size to allow winds to funnel through; and
- be separated by sufficient distance from the hazard so as not to be consumed and become a hazard itself.

#### A5.4 Vegetation Management

Where APZs have been incorporated as part of the development approval for subdivision or for dwelling construction, the environmental aspects of the development should have already been taken into account.

In general, it is expected that APZs will be maintained by the owner of the land including maintenance of any fire trail constructed as part of the development.

It is accepted practice that after construction of a dwelling, gardens will be established and landscaping of the grounds will be undertaken. It is essential that efforts to reduce fuels on adjoining properties are therefore not negated by actions within the immediate curtilage of the building.

In terms of priorities of addressing bush fire attack, priority should be given to preventing flame impingement by not allowing fine debris to accumulate close to the building. Secondly, removal of understorey fuels aids in the reduction of flame heights and likely canopy fire, thereby reducing overall radiant heat. Removal of loose bark and fine fuels reduces both heat output and ember generation, while the retention of taller trees with canopies will also assist in filtering out embers.

To maintain a garden that does not contribute to the spread of bush fires, it is necessary to plan the layout of the garden beds and take an active decision to minimise certain features in favour of other features. These should include:

- maintaining a clear area of low cut lawn or pavement adjacent to the house;
- keeping areas under fences, fence posts and

- gates and trees raked and cleared of fuel;
- utilising non-combustible fencing and retaining walls
- breaking up the canopy of trees and shrubs with defined garden beds;
- organic mulch should not be used in bush fire prone areas and non flammable material should be used as ground cover, eg Scoria, pebbles, recycled crushed bricks.
- planting trees and shrubs such that:
  - the branches will not overhang the roof;
  - the tree canopy is not continuous; and
  - there is a windbreak in the direction from which fires are likely to approach.

The RFS has developed its document “Standards for Asset Protection Zones” which should be consulted for APZ specifications. This is also available on the RFS web page at [www.rfs.nsw.gov.au](http://www.rfs.nsw.gov.au).

#### A5.5 Maintenance of Property

Sensible arrangements for landscaping and maintenance of the property are critical in the prevention of losses.

In considering property maintenance the following items should therefore be implemented in advance of the bush fire season:

- removal of material such as litter from the roof and gutters;
- ensure painted surfaces are in good condition with decaying timbers being given particular attention to prevent the lodging of embers within gaps;
- check pumps and water supplies are available and in working order;
- driveways are in good condition with trees not being too close and forming an obstacle during smoky conditions;
- check tiles and roof lines for broken tiles or dislodged roofing materials;
- screens on windows and doors are in good condition without breaks or holes in flyscreen material and frames are well fitting into sills and window frames;
- drenching or spray systems are regularly tested before the commencement of the fire season;
- hoses and hose reels are not perished and fittings are tight and in good order;
- doors are fitted with draught seals and well maintained;
- mats are of non combustible material or in areas of low potential exposure; and
- woodpiles, garden sheds and other combustible materials are located downslope and well away from the house.

Trees and other vegetation in the vicinity of power lines and tower lines should be managed and trimmed in accordance with the specifications in “Vegetation Safety Clearances” issued by Energy Australia (NS179, April 2002).

## **AS 3959**

Australian Standard AS 3959 Construction of buildings in bushfire-prone areas, Standards Australia, 1999, that outlines construction standards applicable to residential developments in bush fire prone areas.

## **Asset Protection Zone (APZ)**

Often referred to as a fire protection zone. Aims to protect human life, property and highly valued public assets and values. An area surrounding a development managed to reduce the bush fire hazard to an acceptable level. The width of the APZ will vary with slope, vegetation and construction level. The APZ, consisting of an area maintained to minimal fuel loads and, for subdivision, comprising a combination of perimeter road, fire trail, rear yard or a reserve, so that a fire path is not created between the hazard and the building.

## **Bush fire protection measures (BPM)**

The suite of measures available for minimizing the risk of bush fire attack and the threat to life and property.

## **Building Code of Australia (BCA)**

The Building Code of Australia means the document of that name published on behalf of the Australian Building Codes Board (ABCB) (as amended), together with:

- a) such amendments made by the Board, and
- b) such variations approved by the Board in relation to New South Wales, as are prescribed by the EP&A Regulations.

There are 10 classes of buildings as defined by the BCA (see Appendix 1).

## **Building footprint**

The area shown on a plan over which a building can be erected.

## **Bush fire (also Bushfire)**

A fire involving grass, scrub or forest.

## **Bush fire attack**

Arises from direct flame impingement, radiant heat or ember attack.

## **Bush fire hazard**

The potential severity of a fire. Usually measured in terms of intensity (kW/m), the factors that influence a bush fire hazard include climate and weather patterns, vegetation (fuel quantity, distribution and moisture) and slope.

## **Bush fire hazard reduction works**

- a) the establishment or maintenance of fire breaks on land, and

- b) the controlled application of appropriate fire regimes or other means for the reduction or modification of available fuels within a predetermined area to mitigate against the spread of a bush fire,

but does not include construction of a track, trail or road.

## **Bush fire prone area/land**

Is an area of land that can support a bush fire or is likely to be subject to bush fire attack. In general, a bush fire prone area is an area mapped for a local government area that identifies the vegetation types and associated buffer zones. Bush fire prone land maps are prepared by local councils and certified by the Commissioner of the RFS.

## **Bush fire prone land map (BPL Map)**

for an area means a map certified under section 146(2) of the EP&A Act.

## **Bush fire protection measures (BPMs)**

are a range of measures (controls) available to minimise the risk arising from a bush fire. BPMs include APZs, construction standards, suitable access arrangements, water and utility services, emergency management arrangements and landscaping.

## **Bush fire risk**

Is the chance of a bush fire igniting, spreading and causing damage to assets of value to the community. Risk may be rated as being extreme, major, moderate, minor or insignificant and is related to the vulnerability of the asset.

## **Bush fire safety authority**

An approval of the Commissioner of the NSW RFS required for a subdivision for residential or rural residential purpose or for a special fire protection purpose listed under section 100B(6) of the RF Act. This form of development is considered to be integrated development.

## **Bush fire assessment report**

A report submitted in support of a development application by an applicant which determines the extent of bush fire attack to a development and the measures used to mitigate that attack. Appendix 4 provides the information requirements for a bush fire assessment. See also clause 46 of the RF Regulation.

## **Certifying Authority**

As defined in the EP&A Act. Those with authority to issue Part 4A and Complying Development Certificates.

## **Consent Authority**

Is defined in the EP&A Act, in relation to Development Consents. Usually the local council.

**Defendable space**

Is an area within the asset protection zone that provides an environment in which a person can undertake property protection after the passage of a bush fire with some level of safety.

**Development**

Is defined in the EP&A Act.

**Development Application (DA)**

An application for consent to carry out development such as building, subdivision, or the use of a building or land. Applications are normally made to the local council.

**Ecologically Sustainable Development (ESD)**

As defined in section 6 of the *Protection of the Environment Administration Act (NSW) 1991*.

**Ecotourist developments**

aim to foster environmental and cultural understanding, appreciation and conservation and to be ecologically sustainable (being located in a relatively undisturbed natural area).

**Equivalent to an APZ**

is when the building will be separated from the bush fire hazard by other development (including roads, other buildings and managed properties) with a setback distance greater than or equal to the distance which would have been occupied by an APZ, if the development had been established having regard to the provisions of Appendix 3 of this document.

**Fire Intensity**

the rate of heat release, per unit length of fire front. The primary unit is kilowatts per metre of fire front (kW/m). It is a function of the heat content of the fuel (H), the weight of the fuel consumed (W), and the rate of spread of the fire (r).

**Fire protection systems.**

In this document the term is used to refer to the use of drencher/sprinkler systems used to dispense water on to the walls, roof, windows and other elements of a building.

**Flame zone**

The distance from a bush fire at which there is significant potential for sustained flame contact to a building. Determined by the calculated distance at which the radiant heat of the design fire exceeds 29kW/m<sup>2</sup> or calculated by the sustained flame length, whichever is the lesser.

**Infill development**

refers to the development of land by the erection of or addition to a residential building (or buildings) which does not require the spatial extension of services including public roads, electricity, water or sewerage and is within an existing allotment.

**Integrated development**

is development referred to under section 91 of the EP&A Act.

**Integrated housing**

development means a subdivision into two or more lots and the simultaneous design and construction of dwellings.

**Local Environmental Plan (LEP)**

Local Environmental Plan prepared under Part 3 of the EP&A Act. Plans prepared by a council that describe the planning status (zone) and/or development standards required for the future development of an area.

**Public road**

is an area that is open to or used by the public and is developed for, or has as one of its main uses, the driving or riding of motor vehicles.

**Setback**

The distance required through planning provisions to separate a building from the bush fire hazard, street frontage or from adjacent buildings.

**Should**

This is to be read as a prescriptive requirement but recognises that there are exceptional circumstances that warrant consideration of a bush fire protection measure based on performance and the merits of the case including provision for community safety.

**Special fire protection purposes**

are defined in Appendix 3.1.

**State Environmental Planning Policy (SEPP)**

is an environmental planning instrument prepared under Part 3 of the EP&A Act

**Subdivision**

of land means the division of land into two or more parts that, after the division, would be obviously adapted for separate occupation, use or disposition. The division may (but need not) be effected:

- (a) by conveyance, transfer or partition, or
- (b) by any agreement dealing, plan or instrument rendering different parts of the land available for separate occupation, use or disposition.

It includes strata subdivision, community title and boundary adjustments.

**Vegetation formations (and sub-formations)**

are different vegetation types and classes defined by Keith D. 2004 in: "Ocean Shores to Desert Dunes" published by DEC.

# References and other Reading

- Alexander, M.E.** (1982) "Calculating and Interpreting Forest Fire Intensities." *Can. J. Bot.* 60:349-357.
- AUSLIG** (1990) "Atlas of Australian Resources, Third Series, Volume 6, Vegetation". Commonwealth of Australia
- Australia ICOMOS** (2004) Illustrated Burra Charter.
- Australian Building Codes Board** (2006) "Building Code of Australia". Commonwealth of Australia
- Byram, G.M.** (1959). Combustion of Forest Fuels in: "Forest Fire Control and Use" (Ed. Davis, K.P.) McGraw-Hill, New York.
- Catchpole, W.R., Bradstock, R.A., Choate, J., Fogarty, L.G., Gellie, N., McCarthy, G.J., McCaw, W.L., Marsden-Smedley, J.B. and Pearce, G.** (1998) Co-operative Development of Equations for Heathland Fire Behaviour. In 'Proc. 3rd Int. Conference. Forest Research and 14th Conf. on Fire and Forest Meteorology'. (Ed. Viegas, D.X.) Luso, Coimbra, Portugal, 631-645.
- Cheney P. and Sullivan A.** (undated) "Comment on Risk Analysis Process for NSW". CSIRO Forest and Forest Products Division.
- CSIRO** (2000) "Review of Current Methodology of Assessment of Bush fire Hazard and the Prescription of Appropriate Separation Distances and Building Standards. The Development of a Robust Model to Achieve this for Different Vegetation Types". Client Report 901, CSIRO Forestry & Forest Products Division Bush fire Behaviour and Management Team, ACT.
- CSIRO** (2005) "Review of Methodology for prescribing separation distances between structures and vegetation." Client Report No. 1537, CSIRO Forestry and Forest Products Division, Feb. 2005.
- Department of Planning, NSW** (1989) "Circular C10: Planning in Fire Prone Areas." (Departmental circular)
- Douglas, G.B. and Ellis, P.** (2001) "Integrating Land Use Planning and Construction Standards for Protection of Bush Fires in NSW – a Model". Bushfire 2001, Christchurch, New Zealand.
- Douglas, G.B. and Tan, Z.** (2005) Integrating Site Assessment and Performance Planning Outcomes for Bushfire Prone Areas at "Planning for Natural Hazards – How we can Mitigate the Impacts?" Symposium, University of Wollongong, 2-5 February 2005. Wollongong..
- Douglas G.B., Tan Z. and Midgley S.** (2006) A Verification Method for Evaluating Alternative Building Solutions in Bushfire-Prone Areas. at International Fire Safety Engineering Conference 2006, Gold Coast, 23 May 2006.
- Energy Australia** (2002) "Vegetation Safety Clearances" (NS179).
- Forestry Commission of NSW** (1991) Control Burning in Eucalypt Forests, Metric Conversion of McArthur Leaflet 80, Sydney.
- Gill, A.M. et al.** (ed) (1981) "Fire and the Australian Biota" Australian Academy of Science, Canberra.
- Good R.** (1994) "Fuel Dynamics, Preplan and Future Research Needs". Pers. Communication.
- Haddad, S.G.** (1982) "A Systematic Approach to Risk Assessment for Major Plants", CHEMECA '82, University of Sydney, NSW.
- Healey et al** (ed) (1985) "The Economics of Bush fires: The South Australian Experience" Oxford University Press Melbourne.
- Keith D.** (2004) "Ocean Shores to Desert Dunes", Department of Environment and Conservation, Sydney.
- Leicester, R.H.** (1987) "Building Technology to Resist Fire, Flood and Drought." Operations January 21, 1987, The Fireman, Oakleigh
- Luke R.H. and McArthur, A.G.** (1978) "Bush Fires in Australia" Australian Government Publishing Service, Canberra.
- Noble, I.R., Bary, G.A.V. and Gill, A.M.** (1980) McArthur's fire-danger meters expressed as equations. *Aust. J. Ecology* 5:201-203.
- Ramsay, C and Rudolph, L** (2003) "Landscape and Building Design for Bush fire Areas". CSIRO Publishing, Collingwood.
- Ramsay G.C. and Dawkins D.** (eds), (1993) "Building in bush fire prone areas – Information and advice", Standards Australia (SAA HB 36-1993).
- Rural Fire Service NSW** (2005) "Standards for Asset Protection Zones"
- Specht, R.L.** (1972) Chapter 2 - Vegetation in Leeper, G.W. (Ed) "The Australian Environment. 4th Edition. CSIRO and Melbourne University Press, Melbourne.
- Standards Australia**, (1993) "AS 1530.2, Methods for fire test on building materials, components and structures - Test for flammability of materials".
- Standards Australia**, (1997) "AS 4083, Planning for Emergencies - Health Care Facilities".
- Standards Australia**, (1999) "AS 3959, Construction of buildings in bushfire prone areas".
- Standards Australia**, (2002) "AS/NZS 1596 The Storage and Handling of LP Gas"
- Standards Australia**, (2002) "AS/NZS 2890.2 Parking facilities - Off-street commercial vehicle facilities".
- Standards Australia**, (2002) "AS 3745, Emergency control organization and procedures for buildings, structures and work places."
- Standards Australia**, (2005) "AS 2419.1 – 2005 Fire hydrant installations – System design, installation and commissioning"
- Watson P.** (2005) Chapter 9 Fuel Accumulation in "Fire Frequencies for Western Sydney's Woodlands: Indications from Vegetation Dynamics". Doctor of Philosophy, University of Western Sydney.
- Webster, J.K.** (1986) "The Complete Australian Bushfire Book." Nelson. Vic.
- Wilson A.A.G.** (1984) "Assessing the Bushfire Hazard of Houses: A Quantitative Approach". Rural Fire Research Centre, Vic.
- Wilson, A.A.G. and Ferguson I.S.** (1984) "Australian Forestry", pp230-236. "Fight or Flee? – A Case Study of the Mount Macedon bushfire".

15.2 GUIDELINES FOR THE PREPARATION OF  
EMERGENCY/EVACUATION PLAN (RFS)

---

Document Title:	<b>Bushfire Management Plan – Rix's Creek Mine</b>		Document Owner:	<b>Chris Knight</b>	
Prepared By:	Chris Quinn	Print Date:	1-Apr-26	Version No:	1.3
Reviewed By:	Julius Harris-Payne	Review Frequency:	<b>As Required</b>	Issue Date:	1/04/2026
Approved By:	Brendon Clements			Page No:	33 of 35



NSW RURAL FIRE SERVICE



# DEVELOPMENT PLANNING

A guide to developing a  
Bush Fire Emergency Management and  
Evacuation Plan

PREPARE.

ACT.

SURVIVE.



© State of New South Wales through the NSW RURAL FIRE SERVICE 2014

The NSW RURAL FIRE SERVICE (NSW RFS) encourages the availability, dissemination and exchange of public information. You may copy, distribute, display, download and otherwise freely deal with this material for personal, in-house or non-commercial use, on the condition that you include the copyright notice © State of New South Wales through the NSW RURAL FIRE SERVICE 2014 on all such uses. In the event that you wish to copy, distribute, display, download, store, or use this material for a purpose other than personal, in-house or non-commercial use, you must obtain permission from the NSW RFS by writing to the following address:

Commissioner  
NSW RURAL FIRE SERVICE  
Locked Mail Bag 17  
Granville NSW 2142

You must also obtain permission from the NSW RFS if you wish to:

- charge others for access to the work (other than at cost);
- include all or part of the work in advertising or a product for sale;
- modify the material; or
- use any trade mark from this publication, including the NSW RURAL FIRE SERVICE Crest.

#### **DISCLAIMER STATEMENT**

While the material within this publication is current at the time of writing changes in circumstances after the time of publication may impact on the accuracy of the material. Individuals are responsible for ensuring they have the most current version of this publication

The information and material contained herein is general in nature and is intended for your use and information. The NSW RURAL FIRE SERVICE (NSW RFS) disclaims, to the extent permitted by law, all warranties, representations or endorsements, express or implied, with regard to the material contained herein. The NSW RFS does not warrant or represent that the material contained herein is free from errors or omissions, or that it is exhaustive. Users should exercise their own skill and care with respect to its uses. You must not assume that this material will be suitable for the particular purpose that you had in mind when using it.

The NSW RFS disclaims any liability (including but not limited to liability by reason of negligence) to the users of the material for any loss, damage, cost or expense whether direct, indirect, consequential or special, incurred by, or arising by reason of, any person using or relying on the material and whether caused by reason of, any error, omission or misrepresentation in the material or otherwise. Users of the Website will be responsible for making their own assessment of the material and should verify all relevant representations, statements and information with their own professional advisers.

Prepared by NSW Rural Fire Service -December 2014

## Table of Contents

Preface	4
What is an at risk development?	5
Why develop a Plan?	5
What if I already have an Emergency Plan?	6

---

### **STEPS TO PRODUCE A PLAN** **7**

STEP 1: Establish an Emergency Planning Committee	8
STEP 2: Analyse site characteristics	9
STEP 3: Decide Primary Action	13
Analyse the bush fire situation	13
STEP 4: Analyse requirements for Sheltering and Evacuation	14
Identify a refuge (sheltering)	15
Identify a refuge (evacuation)	16
Determining transportation to refuge (evacuation)	17
STEP 5: Develop emergency procedures	18
Bush Fire Action Statements	18
Factors to be considered for Action Statements	19
Occupant/employee listing	20
Contact details of family members	20
Site layout	21
STEP 6: Training of staff/occupants	22
Additional Awareness Training	22

---

### **TEMPLATE**

Bush Fire Emergency Management and Evacuation Plan	
APPENDIX 1: Example Bush Fire Action Statements and Triggers	
APPENDIX 2: Example of a Site Layout	



## **Preface**

This guide is aimed at assisting representatives for at risk developments to prepare a Bush Fire Emergency Management and Evacuation Plan (Plan).

For new developments in bush fire prone areas, conditions of consent may also require the preparation of a Plan.

The guide will assist in filling out the Bush Fire Emergency Management and Evacuation Plan Template provided in this document.

The guide outlines a step-by-step process to address factors that are to be considered when developing a Plan. There are six steps in the process. As each step is completed, details should be recorded in the template.

Where a Plan is required to meet a development consent condition, a copy is likely to be required by the certifying authority.

You should also consider providing a copy to the local Fire Service to assist in their pre-incident planning.

Individuals wanting to consider their bush fire emergency management should refer to the Bush Fire Survival Plan available at [www.rfs.nsw.gov.au](http://www.rfs.nsw.gov.au).

If you would like more information on emergency management planning for bush fires, please contact:

NSW Rural Fire Service  
Locked Mail Bag 17  
GRANVILLE NSW 2142  
1800 NSW RFS  
(1800 679 737)  
[www.rfs.nsw.gov.au](http://www.rfs.nsw.gov.au)

## What is an at risk development?

At risk developments are facilities that regularly have a large number of occupants that may rely on others for their wellbeing or be unfamiliar with the local area. As such a greater degree of planning and coordination is required to ensure occupants safety. In the event of a bush fire, a Bush Fire Emergency Management and Evacuation Plan (Plan) will outline what actions are to occur and arrangements for relocation.

*The Environmental Planning & Assessment Act (1979)* and the *Rural Fires Act (1997)* provides for developments on Bush Fire Prone Land to incorporate bush fire protection measures to reduce the impacts of a bush fire. This legislation, along with the NSW RFS publication, Planning for Bush Fire Protection, refers to Special Fire Protection Purposes (SFPP).

An at risk development includes, but is not limited to, those facilities that are often referred to as SFPP development. Typically, a SFPP development includes the following:

- a school
- a child care centre
- a hospital
- a hotel, motel or other tourist accommodation
- a building wholly or principally used as a home or other establishment for mentally incapacitated persons
- seniors housing within the meaning of State Environmental Planning Policy (Housing for Seniors or People with a Disability) 2004
- a group home within the meaning of State Environmental Planning Policy No 9—Group Homes
- a retirement village.

Other development types that may need to consider a Bush Fire Emergency Management and Evacuation Plan include commercial/industrial, multiple occupancy (land sharing) and community title estates.

## Why develop a Plan?

Bush fires are a part of the Australian environment, with NSW being one of the more bush fire prone areas in the world. As the population increases, development encroaches further into bush land areas, increasing the number of persons and property potentially affected by bush fires.

### **Bush fire attack essentially takes five forms:**

**Wind:** Strong winds resulting from severe bush fires will drive embers into vulnerable areas of a building, preheat and dry fuel ahead of a fire, lift roofing and extend flames along a more horizontal plane closer to building elements.

**Smoke:** While smoke will cause minimal damage to property, it can severely affect the health of residents. Smoke is a significant factor in at risk developments, particularly where residents are susceptible to respiratory disorders. Smoke can also reduce visibility during evacuation or shelter situations.

**Embers:** Ember attack is responsible for most bush fire related building fires. Embers can also cause spotting in advance of the bush fire and ignite building elements.

**Radiant heat:** Radiant heat can severely impair the health of residents and the integrity of building elements. Radiant heat can prevent emergency services personnel assisting occupants of at risk developments.

**Flame:** Flame attack will severely restrict fire fighting operations, resulting in the ignition of building elements and a threat to the health of residents and their capacity to evacuate the area.

**The preparation of a Plan aims to improve the preparedness of at risk developments from bush fire attack. The plan should identify the steps to be followed in the event of a bush fire.**

## What if I already have an Emergency Plan?

Many facilities have procedures to facilitate the safe movement and assist in the evacuation of occupants. These procedures are normally referred to as an Emergency Plan as outlined in Australian Standard AS3745 Planning for emergencies in facilities 2010 and AS4083 Planning for emergencies – Health care facilities 2010.

An Emergency Plan provided by these standards, has occupants evacuate buildings to an assembly point in the event of an emergency. However for bush fires, these procedures may not adequately address the safety of occupants and other related issues that may result from a bush fire emergency. For example occupants may be relocated out into the open, exposing them to the heat and smoke from a bush fire.

A Bush Fire Emergency Management and Evacuation Plan will identify appropriate procedures for occupants to follow in the event of a bush fire and is to contain the following minimum requirements:

- Name and address of facility
- Contact details (including phone number)

- Number of employees/occupants
  - Number of occupants with support needs
  - Primary Action: (evacuate or shelter)
  - Details of location or address of Primary Action
  - Details of location or address of back-up/ pre-emptive procedures
  - Procedures for Primary Action and back-up actions
  - Assembly point(s) and transportation arrangements (evacuation only)
  - Action Statements (before, during and after a bush fire)
  - Site layout of facility
- Attachments will be dependent upon the type of facility and other associated factors. These attachments may include;
- Occupant/employee listing
  - Contact details for parents/guardians

The NSW RFS recommends the use of the template provided in Appendix 1 as it provides the basis of a Plan and addresses the above requirements.



# STEPS to produce a plan

- STEP 1 >** Establish an Emergency Planning Committee (EPC)
- STEP 2 >** Analyse site characteristics
- STEP 3 >** Decide Primary Action (evacuation or sheltering)
- STEP 4 >** Analyse the requirements for evacuation and sheltering
- STEP 5 >** Develop emergency procedures -Bush Fire Action statements
- STEP 6 >** Training staff and occupants

# STEP 1 >

## Establish an Emergency Planning Committee

The first step is to establish an Emergency Planning Committee (EPC) if one has not yet been established for your facility.

The EPC is a consultative group comprised of a representation of those who may work, live or are occupants at the facility. The group normally consists of senior management, tenants, staff and chief and deputy chief wardens.

The role of the EPC is to actively participate in the planning process and identify the roles and likely participants who will be responsible for the implementation of the Plan and its procedures during an emergency.

The role of the EPC is to:

- > establish and implement emergency plans and procedures
- > identify duties and responsibilities of positions
- > formulate emergency procedures
- > ensure employees and other occupants are educated and trained on emergency procedures
- > ensure all occupants are aware of the emergency procedures for the development
- > Regularly review the plan to ensure it remains practical and current

Roles and responsibilities associated with a Plan will need to be assigned to staff including:

- > coordinating and arranging transport
- > physically relocating occupants from one place to another
- > ensuring all buildings are properly prepared to limit the impact of a bush fire
- > initiating any bush fire protection measures such as sprinkler systems
- > liaising with emergency services.

If there is an existing EPC, it is likely that there is an existing Emergency Plan, with roles and responsibilities. The Emergency Plan should be cross referenced for bush fire emergencies.

For information on chief warden and warden positions, refer to Australian Standards AS3745 Planning for emergencies in facilities 2010 and AS4083 Planning for emergencies - Health care facilities 2010.

# STEP 2 >

## Analyse site characteristics

To prepare an appropriate Plan you should consider the characteristics of a site such as:

- > the type of facility
- > where is the facility located
- > how it may be affected by a bush fire
- > how many occupants there are and if any occupants have 'support needs' that need to be considered.

Preparing a Plan requires an understanding of how a bush fire may affect a site and the consequences on its occupants. For a better understanding of the bush fire situation of a particular area, consider consulting with the NSW RFS and other emergency services.

As part of the consultation, you should keep the contact details of those people within the different agencies up to date. This will improve communications and will make you aware of any situations that may affect your pre-planning.

To assist in working through potential issues for a site, a range of questions to help in understanding the bush fire situation and how it may affect the facility and the occupants are available on the following pages.

Bush fire prone area is land that can support a bush fire or is likely to be affected by bush fire attack. It is not determined by the frequency in which bush fires may have occurred in the past. Facilities that are within proximity of bush fire prone land should prepare a Bush Fire Emergency Management and Evacuation Plan.

**Contact details for emergency service agencies are to be included in the Bush Fire Emergency Management and Evacuation Plan**



**Is the facility in a bush fire area?**

Yes  No

➤ Contact your local council to determine if you are bush fire prone.

**What type of facility is the Plan for?**

- School
- Hospital
- Child care centre
- Commercial buildings
- Seniors Living
- Industrial buildings
- Group Home (SEPP 9)
- Tourist (hotel or motel)
- Mental health facility
- Other tourist accommodation (eg. caravan park or camping)
- Retirement Village
- Other

The logistical arrangements for the numbers of occupants within the facility may be complicated and you may need to consider alternate accommodation, transport, health care, food supplies and staffing ratios.

**How many occupants within the facility?**

.....

**How many occupants reside within the facility?**

.....

**How many staff work within the facility?**

.....

**What is the staff/occupant ratio?**

.....

**How many potential temporary occupants (tourists, school students, visitors etc.)**

.....

### Are any of the following occupants types at the facility and if so how many?

- \_\_\_\_\_ Children (under five years of age)
- \_\_\_\_\_ Tourists (caravan/camping)
- \_\_\_\_\_ Children (primary school)
- \_\_\_\_\_ Tourists (motel/resort)
- \_\_\_\_\_ Children (high school)
- \_\_\_\_\_ Day time only employees
- \_\_\_\_\_ Dependent aged
- \_\_\_\_\_ Independent aged
- \_\_\_\_\_ Mentally/physically disabled
- \_\_\_\_\_ Other \_\_\_\_\_

- The type and number of occupants may influence where these occupants should take refuge during a bush fire emergency.
- The type of occupants may influence Action Statements.
- With tourists, for example, you may need to consider whether they know the local area and have bush fire awareness.
- Older persons may have restricted mobility and require assistance if relocated.
- Children require supervision and their age will determine the level of supervision.

### Are there occupants who suffer from asthma or other medical conditions where smoke or anxiety may exacerbate their illness or condition?

Yes  No

- If yes, it may be more appropriate to move these people from the facility to a location away from the effects of a bush fire well in advance.

**Asset Protection Zones (APZ)** provide space for fire fighters and other emergency service personnel to support or evacuate occupants and reduce the impacts of radiant heat, smoke and embers on them whilst this is occurring.

### Is there an APZ in place that will limit a bush fire spreading to a building or a bush fire starting around a building?

Yes  No

- You should consult with the NSW RFS to determine if APZs are suitable.
- Refer to Standards for Asset Protection Zones for maintenance requirements of an APZ
- If yes, the facility may be suitable for occupants to remain on-site and indoors away from the effects of a bush fire as a Primary Action (on-site refuge).
- If no, consider a plan with Primary Action to evacuate occupants early to another location away from the effects of a bush fire (off-site refuge).

**Safe access arrangements** for residents to evacuate an area whilst emergency service personnel are accessing the same area to suppress a bush fire are essential. Alternative access/way out routes will also assist if part of the road system is cut by bush fire.

**How accessible is the property within the local area?**

- Multiple roads in and out of the property
- One road in and out
- Multiple roads provide alternative routes to transport occupants to an off-site refuge.
- A single road accessing the site may cause traffic problems. Early departure, well before fire fighting units arrive, is recommended.

**Does the transport route go through or near potential bush fire areas?**

- Yes  No
- It is not appropriate to move occupants through an area where a bush fire may be burning or is predicted to burn through.
  - Alternate travel routes may need to be considered.

**What is the condition of the buildings on site?**

- Well maintained
- Reasonably maintained
- Poorly maintained
- Older buildings or poorly maintained buildings are more vulnerable to bush fire attack, especially embers.
- Gardens adjacent to buildings are a source of fuel for a fire.

**Are the buildings constructed against bush fire attack?**

- Yes  No  Unknown
- Australian Standard AS3959 Construction of buildings in bush fire prone areas outlines building standards.
  - Windows and doors are vulnerable to bush fire attack and provide possible entry points into the building for embers.

Appropriately prepared and constructed buildings can offer protection during a bush fire reducing the likelihood of bush fire related injury and fatality.

# STEP 3 >

## Decide Primary Action (sheltering or evacuation)

The decision to evacuate or shelter under general bush fire conditions is one of the more important decisions to be made. This decision needs to be based upon a good understanding of the location, occupants and the effects of bush fire.

### What is the difference between sheltering and evacuation?

**Sheltering** is the process of moving people to a location that is within close vicinity of where they occupy, but away from the effects of a bush fire (eg. moving school children to a gymnasium, or moving occupants to a common room).

> Sheltering requires an on-site refuge which is a building within the property that is able to adequately accommodate the occupants that has adequate protection from the effects of bush fire.

**Evacuation** is the process of moving people from where they are staying to another location some distance away from the effects of a bush fire, to a safer location.

> Evacuating requires an off-site refuge which is a building or location some distance away from the property and from the effects of bush fire that is able to accommodate all the occupants being evacuated.

### Analyse the bush fire situation

Analysing the bush fire situation should provide an understanding of how a bush fire may affect the site and its occupants. The following questions have been provided to assist in deciding whether the Primary Action should be to evacuate or to shelter.

#### Is the facility likely to be affected by radiant heat and or direct flames?

Yes  No

If yes, safe evacuation is more appropriate

#### Are there occupants that could be susceptible to smoke who should be moved to another location due to medical conditions?

Yes  No

If yes, safe evacuation is more appropriate

#### Are there buildings with adequate Asset Protection Zones and building standards located away from a direct bush fire threat?

Yes  No

If yes, sheltering may be appropriate

# STEP 4 >

## Analyse requirements for sheltering and evacuation

**Procedures for both sheltering and evacuation are to be developed**, with one identified as the Primary Action to be followed during a bush fire. This is to ensure that if for any reason the Primary Action is not achievable, the facility is not left without procedures to follow.

- > Facilities with sheltering as their Primary Action will have evacuation procedures in case they can no longer shelter or emergency services call for a pre-emptive evacuation due to catastrophic or extreme bush fire conditions.
- > Facilities with evacuation as their Primary Action will have sheltering procedures to implement in case a bush fire occurs and there is insufficient time to evacuate.

While it may be appropriate to plan to shelter if there is a bush fire emergency, this may not always be feasible particularly during extreme or catastrophic conditions. Emergency services may decide to evacuate areas for public safety. For this reason procedures to evacuate to a refuge are required to ensure the necessary planning and coordination arrangements are in place.

Work through both the evacuation and sheltering steps when developing your Plan – no matter which is identified as your Primary Action.

An important factor when planning for emergency procedures is that under intense conditions it is common for people to behave irrationally and this may increase the time taken to move people.

## Identify an on-site refuge

A refuge is required when sheltering and should be a building within the site that is able to accommodate all occupants away from the effects of the bush fire.

Sheltering is generally used where the facility includes buildings that are away from a direct threat of a bush fire during general bush fire conditions. Remember that emergency services may call for a pre-emptive evacuation of the facility for public safety.

Sheltering procedures are also important as a back up option. Bush fires can start within close proximity to the property, leaving insufficient time for evacuation. In these circumstances occupants are more likely to be safer remaining in an on-site refuge on site rather than trying to evacuate.

**When identifying a refuge, consider the following:**

**Is the property well maintained and kept free from a build up of fuel and leaf litter in gutters and around buildings?**

Yes  No

- Refer to Standards for Asset Protection Zones (NSW RFS publication) for further advice.

**Is there a building on-site that is away from bushland and unlikely to be impacted by bush fire?**

Yes  No

- Consider a common room, gymnasium, meeting room or hall for occupants to relocate to.
- Consider the potential for any adjoining structures, vegetation or combustibles to ignite and impact on the building.
- For facilities where occupants are located in numerous buildings or rooms, it may be appropriate to remain in those rooms under supervision.

**Is the building constructed in such a manner that minimises bush fire attack with appropriate Asset Protection Zones?**

Yes  No

- To determine standards of construction consult Australian Standard AS3959 Construction for buildings in bush fire prone areas.

**Is there access to amenities (away from the effects of a bush fire)?**

Yes  No

**Is there sufficient supervision of occupants to manage the situation?**

Yes  No

## Identify an off-site refuge (evacuation)

When identifying an off-site refuge, a number of factors will need to be considered, such as location of the refuge, transportation arrangements to the refuge, size and capacity of the refuge and the availability of a facility in the nearby area.

### Do you have occupants with support needs that require a similar facility to support them?

Yes  No

- Occupants with support needs are people with physical, intellectual, visual, or auditory disability or impairment, either temporary or permanent. It also includes aged persons and juveniles who are dependent on others for their care and wellbeing.

### Is the refuge in an area away from the effects of a bush fire?

Yes  No

- Have you considered locations such as community centres, clubs etc. as possible places to go?

### Are there amenities (toilets etc.) available at the refuge?

Yes  No

### Can the refuge accommodate the number of occupants?

Yes  No

- Remember that other persons may wish to utilise the same facility as their refuge.
- Accommodation for more than one day may be required.

### Is the route to the refuge such that it does not require transporting through bush fire affected areas or areas that may be affected by an approaching bush fire?

Yes  No

Depending on the extent of bush areas around the facility, the location of a bush fire and the safest route from the property, there may be a need to have two or three refuges,

Details should include street name and suburb, map reference, refuge name, and the possible route to be taken.

### Determining transportation to off-site refuge (evacuation)

Part of the planning of an evacuation is how people are going to be transported to a refuge. The following may assist in the planning of these transport arrangements.

#### Do you have your own transport for all occupants?

Yes  No

#### Are you going to use private vehicles?

Yes  No

- If using private vehicles, will they be available when you need them and will there be drivers available?
- Will there be sufficient vehicles to transport all the occupants?

#### Have occupants with support needs been considered when determining transportation type?

Yes  No

- Is disabled transportation required, and is this sufficient to move the number of occupants from the facility?

#### Do you require ambulances?

Yes  No

- If relying on ambulances, Ambulance NSW needs to be consulted.

#### Is a community bus available?

Yes  No

- Will community buses be available when you need them and will there be drivers available? Develop a list of transport providers, with their contact names and phone numbers and how many vehicles will be available.
- Will there be sufficient vehicles to transport all the occupants?

#### Are other means of transport available?

Yes  No

#### Do you need any other type of special transport?

Yes  No

- Make arrangements with supplier of transport to have the appropriate vehicles available when required.

**The time it takes to move occupants from the premises to another location is the MINIMUM time required to evacuate safely. TAKE THIS INTO CONSIDERATION AND EVACUATE EARLY.**

# STEP 5 >

## Develop emergency procedures-Bush Fire Action Statements

When moving people around as a result of a bush fire emergency, whether they are able bodied, disabled or unfamiliar with the area, there need to be clear and concise procedures that outline actions to be taken at various stages of the emergency.

There are three key periods of bush fire attack to consider as an approaching bush fire impacts on properties over many hours:

1. As the bush fire approaches: This period can last from 30 minutes to several hours, dependant on the speed and intensity of the fire. Some embers may start to fall around the property, igniting spot fires. The more intense the fire, the earlier the ember attack will start.
2. As the fire front impacts: During this period, which can last from 10 minutes to over an hour, the property will be exposed to ember attack, radiant heat, and the fire front itself. Wind damage may expose parts of a building for embers to enter.
3. After the fire front has passed: For several hours after the fire front has passed, the property will be exposed to ongoing ember attack and spot fires.

### Bush Fire Action Statements

Bush Fire Action Statements outline duties and actions required to be undertaken before, during and after a bush fire emergency, stating clearly who is to do what, and when. They can be separated into three categories; preparation, response and recovery. A trigger is a timeframe, scenario or some other factor that initiates an action. Appendix 1 includes examples of Bush Fire Action Statements and triggers.

Triggers are to be determined and aligned with the appropriate action. Factors to be considered in determining triggers include the decision to evacuate or shelter as this will influence the timeframe required for certain actions to be undertaken.

An example may be if the decision is to evacuate and transport is required and then a timeframe to move occupants would have to be established. This should be used as a trigger to ensure there is adequate time, well before a bush fire approaches, to evacuate these people to an off-site refuge.

STAGE	ACTION	TRIGGER
PREPARATION	What to do in preparation for a bush fire.	When the Bush Fire Season is declared.
RESPONSE	What to do when a bush fire emergency is in the vicinity.	An example may be when the fire is one, four, eight, 12 hours away or one, five 10 kilometres away.
RECOVERY	What to do when a bush fire emergency has passed.	An example may be when advised to return by emergency services.

## Factors to be considered for Bush Fire Action Statements

Bush Fire Action Statements outline duties and actions required to be undertaken in a bush fire emergency. Consideration needs to be made for aspects such as who will coordinate the actions of others, what are people to do, and how will they know where to go. The following are some factors to consider in developing appropriate action statements.

### Do you have an emergency assembly point/area?

Yes  No

- Emergency assembly points are locations within the property where person meet before they are given further instructions.
- These locations should be located such that persons may proceed on foot and away from the threat of fire.
- When a designated assembly point has been determined, the site should be sign posted or have suitable marking to clearly identify the location to evacuees.

## Is security required during a bush fire emergency?

Yes  No

- When the property is evacuated or occupants are moved to the on-site refuge, personal belongings are left behind and they may be vulnerable to theft and vandalism.
- To reduce the possibility of these crimes, consider security for the facility.

Below are some suggested procedures where security is required:

1. Consult with the police on the availability of resources that may be utilised for security.
2. Consult with a security company to engage a security officer (possibly at short notice), only if safe to do so.
3. Have an employee remain and monitor the facility, only if safe to do so.

Note: The use of security personnel and employees would generally be required where damage has been sustained and the occupants are unable to return. Safety of any persons attending the site is paramount.

### Do you have a procedure to inform occupants and/or visitors of emergency procedures for a bush fire emergency?

Yes  No

#### Employees

- Have a meeting and discuss procedures and who does what.
- Include employees in reviewing the plan.

#### Permanent/regular occupants

- Have a community meeting with occupants.
- Provide a site layout showing where the refuge or assembly point(s) are.

#### Temporary occupants

- Have information flyers available during the Bush Fire Season outlining emergency management procedures and bush fire protection measures.
- Have a site layout with designated assembly points or refuge locations posted in each room.

#### Occupant/employee listing

When relocating people, it is necessary to know if all occupants are safe.

### Do you have a procedure to account for occupants during a bush fire emergency?

Yes  No

The accounting of occupants should occur:

- At the emergency assembly area prior to any departure from the property
- At the on-site or off-site refuge, and
- On the return to the facility after the bush fire event.

As part of the accounting procedures, a list is required of all persons and visitors that occupy the facility. The list should include:

- name of person
- the building the person occupies, and
- any support needs of persons during the evacuation.

### Contact details of family members

Contacting the family of the occupants should be included in any Plan. For many places such as schools and child care facilities, parents become very concerned about the wellbeing and safety of their children during times of bush fires.

### Do you have a procedure for contacting occupant's family an during a bush fire emergency?

Yes  No

- Many parents will instinctively want to come and get their children, whether or not this is appropriate. If the area is going to be impacted on by a bush fire, it may not be possible due to road closures that will not allow persons through.
- The plan should consider how to inform the parent and what their actions should be, how the children will be evacuated and the location they will be evacuated to.
- In other situations, children may be concerned about their parent's whereabouts. The same considerations, as mentioned previously should be made.
- A contact person/s may be included on the resident listing form. This will allow any contact to be made after the evacuation at the refuge location.

## Site layout

A site layout is a diagram of the site that shows the locations of buildings, refuge area and other items such as firefighting equipment. Site layouts need to show a number of different features depending upon the size and complexity of the facility. The following features are to be included in the Plan (where applicable):

- Site boundaries
- Internal roadways
- Buildings
- Locations of dangerous goods and any other significant hazardous materials
- Emergency vehicular and pedestrian entrances and exits
- Assembly areas (for evacuations) and address of off-site refuge
- Location of on-site refuge (for Sheltering)
- Fire services (eg. hydrants, boosters, sprinklers, hose reels, deluge valve stations)
- Town mains water supplies and/or on site water tanks
- Location of electrical supply isolation points
- Location of gas supply locations and isolation valve points.

## Have you prepared a site layout of the facility that shows the relevant information?

The site layout should be A3 size, provided as an attachment to the Plan, as well as laminated or framed, and posted in conspicuous locations throughout the building(s).



A copy of the site layout should be placed in each building so they are readily accessible by ALL occupants, visitors and emergency service personnel.

# STEP 6 >

## Training of staff/occupants

For the procedures of this plan to be followed in an orderly manner during an emergency, it is very important that all members of the emergency team and occupants are thoroughly familiar with what is expected of them. For this to occur, it is necessary for the facility to have education on procedures, roles and responsibilities and to undertake exercises to test the emergency procedures.

The Emergency Planning Committee (EPC) that has been established is required to ensure the delivery of education and training for all occupants occurs and to conduct annual exercises on these procedures.

The exercises should test the arrangements and procedures that form the Bush Fire Emergency Management and Evacuation Plan, and include the following:

- > Decision to evacuate or shelter
- > What and where are the evacuation routes and refuges?
- > What are the Bush Fire Action Statements?
- > Who has responsibility and for what?
- > What specific arrangements have been made for transportation and accommodation (if required)?
- > A drill for each scenario should be undertaken each year prior to the Bush Fire Season to make sure everyone understands their roles in an emergency.

### Additional awareness training

Where the decision is to shelter, it is beneficial for occupants to undergo bush fire awareness training to provide an understanding of a bush fire emergency. Where staff members would be required to monitor the building for fire activity (burning embers etc.), it is recommended that they are provided with bush fire awareness/basic firefighting training. Contact your local NSW RFS Fire Control Centre who may be able to assist with this.

For additional information on the education and training of occupants, refer to AS3745 Planning for emergencies in facilities 2010.

## Glossary

<b>assembly point</b>	The designated place or places where people assemble during the course of an evacuation.
<b>District Emergency Management Officer (DEMO)</b>	For emergency management purposes, NSW is divided into emergency management districts. Each Emergency Management District has a District Emergency Management Committee. The Committee is chaired by the District Emergency Operations Controller (DEOCON), supported by the District Emergency Management Officer (DEMO). The DEMO is also responsible for assisting local committees and communities within the relevant District on emergency management matters.
<b>emergency</b>	An event that arises internally, or from external sources, which may adversely affect the occupants or visitors in a facility, and which requires an immediate response.
<b>Emergency Planning Committee (EPC)</b>	Persons responsible for the documentation and maintenance of an emergency plan.
<b>Emergency warning and intercommunication system (EWI)</b>	A combined emergency warning and intercommunication system that facilitates both way communications and control during an emergency.
<b>evacuation</b>	The orderly movement of people from a place of danger.
<b>Local Emergency Management Officer (LEMO)</b>	The State is divided into Local Government areas with a Local Emergency Management Committee for each area. This Committee is chaired by a senior representative of the council, and is supported by a Council appointed Local Emergency Management Officer (LEMO).
<b>occupant</b>	A person attending a facility on a permanent or temporary basis, such as an employee, contractor, student or resident, but not a visitor
<b>on-site refuge</b>	A building within the premises that is able to accommodate the people that will shelter. The place is not under threat from a bush fire.
<b>off-site refuge</b>	A venue at another location some distance away that is able to accommodate all the people being evacuated. The place is not under threat from a bush fire.
<b>relocation</b>	Movement of persons and/or organisations to an alternate area
<b>State Environmental Planning Policy (SEPP)</b>	State Environmental Planning Policy (SEPP) is a legislated policy that deals with issues significant to the state and people of New South Wales.
<b>sheltering</b>	Procedures for a relevant situation where the safest course of action is to remain in a building or location.
<b>support needs</b>	People with physical, intellectual, visual, or auditory disabilities or impairments, either temporary or permanent who require support. It also includes aged persons and juveniles who are dependent on others for their care and wellbeing.



# BUSH FIRE EMERGENCY MANAGEMENT AND EVACUATION PLAN

Name of facility:

.....  
.....

Address

.....  
.....

Prepared by:

.....

Authorised by:

.....

Date: .....

**TO BE REVIEWED ANNUALLY**

## Facility Details

This plan is for: .....  
Name of facility

and has been designed to assist management to protect life and property in the event of a bush fire.

This Plan outlines procedures for both **sheltering** (remaining on-site) and **evacuation** to enhance the protection of occupants from the threat of a bush fire.

The Primary Action to follow under normal bush fire conditions is to:

**Shelter**       **Evacuate**

Contact person: .....

Position / role: .....

Phone number (BH): ..... Phone number (AH): .....

Type of facility: ..... Number of buildings: .....

Number of employees: ..... Number of occupants: .....

Number of occupants with support needs: .....

Provide description of support needs:



## Roles & Responsibilities

The following outlines who has the responsibility of implementing the emergency procedures in the event of a bush fire.

Position	Name or person	Building / area of responsibility	Mobile phone number

## Emergency Contacts

Name of organisation	Office / contact	Phone Number
NSW Rural Fire Service	Local Fire Control Centre	
NSW Rural Fire Service	Bush Fire Information Line	1800 679 737 1800 NSW RFS
NSW Rural Fire Service	Website	<a href="http://www.rfs.nsw.gov.au">www.rfs.nsw.gov.au</a>
NSW Police Force		



# SHELTERING PROCEDURES

Evaluation of the safety of employees and occupants has determined that it would be safer for ALL persons to shelter in a designated refuge.

The following are the designated refuges allocated within the premises.

## Designated refuges

- a. ....
- b. ....
- c. ....
- d. ....

## Procedure for sheltering during a bush fire emergency

Trigger	Action
a.	a.
b.	b.
c.	c.
d.	d.

## After the bush fire emergency

- a. ....
- b. ....
- c. ....
- d. ....



# EVACUATION PROCEDURES

Evaluation of the safety of employees and occupants has determined that it would be safer for ALL persons to evacuate to a designated refuge.

## Designated assembly points

- 1. ....
- 2. ....
- 3. ....
- 4. ....

## Refuge (primary)

Name of venue (primary): .....

Address of venue: .....

Nearest cross-street:.....

Map reference:.....

Phone number:.....

## Transportation arrangements

Number of vehicles required: .....

Name of organisation providing transportation: .....

Contact phone number: .....

Time required to have transportation available: .....

Estimated travelling time to destination:.....

## Refuge (alternate)

Name of venue (alternate): .....

Address of venue: .....

Nearest cross-street:.....

Map reference:.....

## Transportation arrangements

Number of vehicles required: .....

Name of organisation providing transportation: .....

Contact phone number: .....

Time required to have transportation available: .....

Estimated travelling time to destination:.....

**Before and at the commencement of the Bush Fire Danger Period, we will:**

- a. ....
- b. ....
- c. ....
- d. ....



**Procedures for evacuation in the event of a bush fire**

Trigger	Action
a.	a.
b.	b.
c.	c.
d.	d.

**After the bush fire event**

- a. ....
- b. ....
- c. ....
- d. ....

 **Attachments**

-  Occupant/employee listing
-  Contact details for parents/guardians
-  Site Layout of Premises

# APPENDIX 1

## Example Bush Fire Action Statements and triggers

The following are examples of some actions statements and when they should occur (triggers). You may identify additional statements and triggers relevant to your situation.

### Before and at the commencement of the Bush Fire Danger Period:

- Ensure that the staff are prepared in accordance with the Bush Fire Emergency Management and Evacuation Plan.
- Ensure that all persons are informed of the evacuation/shelter-in-place procedures.
- Ensure that families are provided with a copy of the procedure “What to do if the centre is to be evacuated” upon arrival at the centre (for schools and child care centres etc).
- Ensure building and areas around buildings are prepared and maintained.
- Ensure any firefighting equipment (hoses etc.) is serviceable and available.
- Update contact details of staff and occupants.
- Contact and update emergency services with the premises’ contact details.
- Contact refuges for potential use during a bush fire emergency.
- Contact transport suppliers for potential use during a bush fire emergency.

### In the event of a bush fire in the surrounding area, occupants of the premises shall follow the procedure outlined below:

When aware of the bush fire in the local area:

- Consult the NSW RFS website, 1800 NSW RFS, smart phone applications and local firefighting resources for fire situation and updates.
- Inform staff and occupants of the fire situation.
- Ensure that the person in charge, ie. Chief Warden, has a mobile phone and is contactable.

- Advise the local emergency services that the centre is operating, and that it will need to be advised early in the event of an evacuation being necessary.
- Make arrangement for transportation (for evacuation).

### In the event of an approaching bush fire threatening the premises within X hours, the primary action to evacuate/shelter will take place, staff and occupants of the premises shall follow the procedure outlined below:

- Designated Fire Warden will take control of the situation.
- Remain calm and explain to the occupants what is happening.
- Staff to ensure all doors and windows closed within the premises.
- Sheltering
- Move all persons to the designated refuge.
- Ensure all persons are accounted for (use listing of occupants and visitors register).
- The Fire Warden (or person responsible) is to advise the local emergency service (include phone number) that the centre is sheltering-in-place (include how many people and which building on site).
- After all the occupants have been relocated to refuge, nominated staff will commence contacting relevant families affected.
- Maintain situational awareness through radio, NSW RFS website, 1800 NSW RFS, smart phone applications and local firefighting resources.
- Two persons to make regular exterior visual inspection (wearing appropriate protection from bush fire) of the refuge for embers and extinguish where possible or call 000 for assistance.

### Evacuation

- The Fire Warden (or person responsible) is to advise the local emergency service (include phone number) that the centre is being evacuated (include how many people and where they are going).

- Arrange for vehicles to meet at designated assembly point for pick up of persons.
- Contact refuge and inform them of pending arrival.
- Move all persons to the assembly point for evacuation.
- Ensure all persons are accounted for prior to departure (use listing of occupants).
- Ensure all site buildings have all doors and windows closed prior to leaving site.
- At refuge, move all persons inside and ensure all persons are accounted for and safe.
- The Fire Warden (or person responsible) to advise the local emergency service (include phone number) that the all persons have been evacuated and are accounted for and safe at the designated refuge.
- After all the occupants are accounted for and safe at the designated refuge nominated staff will commence contacting families affected.
- Maintain situational awareness through radio, NSW RFS website, 1800 NSW RFS, smart phone applications and local firefighting resources.

**Forced evacuation - as a result of bush fire in the surrounding area and due to its severity, fire authorities require occupants to be evacuated to a refuge.**

- Fire Warden (or person responsible) to liaise with the police/emergency service giving evacuation orders and provide them with the number of persons and any support needs that are to be considered for transportation (if no on-site transportation is available).
- Arrange for vehicles to meet at designated assembly point for pick up of persons.

- The Fire Warden (or person responsible) is to advise the local emergency service (include phone number) that the centre is evacuating due to police direction (include how many people and where they are going).
- Move all persons to the assembly point for evacuation
- Ensure all persons are accounted for prior to departure (use listing of occupants).
- At refuge, move all persons inside and ensure all persons are accounted for and safe.
- The Fire Warden (or person responsible) is to advise the local emergency service (include phone number) that the all persons have been evacuated and are accounted for and safe at the refuge.
- After all the occupants are accounted for and safe at the refuge, nominated staff will commence contacting relevant families affected.
- Maintain situational awareness through radio, NSW RFS website, 1800 NSW RFS, smart phone applications and local firefighting resources.

**When the bush fire threat has passed and the area is deemed safe by emergency services:**

- No person should re-enter any evacuated building until advised by the emergency service.
- The Fire Warden (or person responsible) to arrange the movement of occupants back to the site and or their separate accommodation.
- All occupants are to be accounted for on their return.
- Inform the police/emergency service of the return of persons to the premises.

# Appendix 2

## Example of a Site Layout

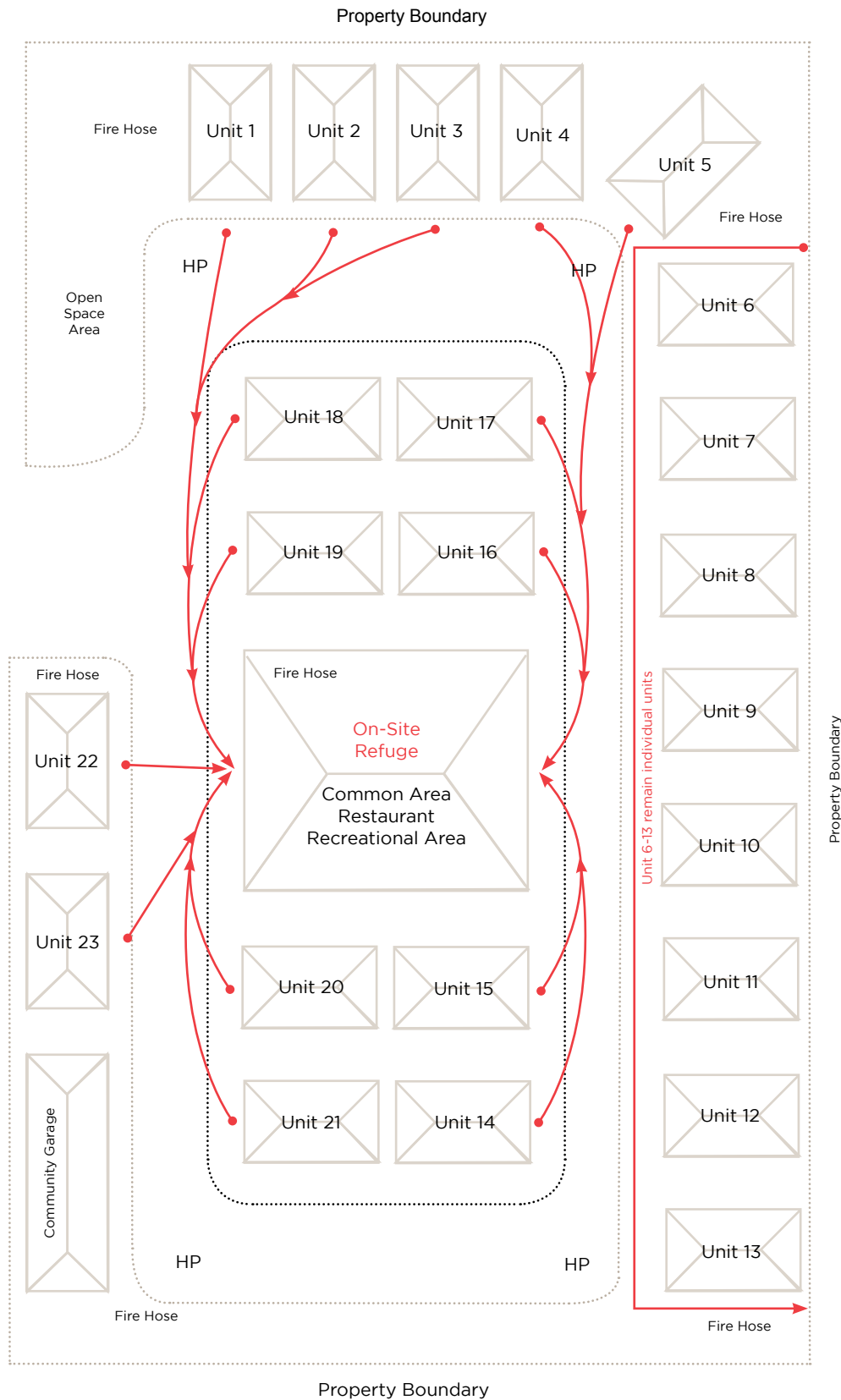

Bush Fire Emergency Management and Evacuation Plan Site Layout Western Hills Retirement Village 321 Olden Road, Summerville  
Decision: Shelter / Contact No: 02 4433 1234

---

**15.3 AUSTRALIAN STANDARD AS 3745 PLANNING FOR EMERGENCIES IN FACILITIES**

---

Document Title:	<b>Bushfire Management Plan – Rix's Creek Mine</b>		Document Owner:	<b>Chris Knight</b>	
Prepared By:	Chris Quinn	Print Date:	1-Apr-26	Version No:	1.3
Reviewed By:	Julius Harris-Payne	Review Frequency:	<b>As Required</b>	Issue Date:	1/04/2026
Approved By:	Brendon Clements			Page No:	34 of 35

AS 3745—2010  
(Incorporating Amendment Nos 1 and 2)

AS 3745—2010



## Planning for emergencies in facilities

Accessed by UNIVERSITY OF NEWCASTLE on 14 Oct 2019 (Document currency not guaranteed when printed)



This Australian Standard® was prepared by Committee FP-017, Emergency Management Procedures. It was approved on behalf of the Council of Standards Australia on 27 October 2010.

This Standard was published on 25 November 2010.

---

The following are represented on Committee FP-017:

- Association of Consultants in Access, Australia
  - Australasian Fire and Emergency Service Authorities Council
  - Australia Post
  - Australian Bomb Data Centre
  - Department of Defence
  - Department of Human Services, Vic.
  - Fire Protection Association Australia
  - Physical Disability Council of Australia
  - Property Council of Australia
  - Safety Institute of Australia
  - University of Western Sydney
- 

This Standard was issued in draft form for comment as DR 10029.

Standards Australia wishes to acknowledge the participation of the expert individuals that contributed to the development of this Standard through their representation on the Committee and through the public comment period.

---

#### **Keeping Standards up-to-date**

Australian Standards® are living documents that reflect progress in science, technology and systems. To maintain their currency, all Standards are periodically reviewed, and new editions are published. Between editions, amendments may be issued.

Standards may also be withdrawn. It is important that readers assure themselves they are using a current Standard, which should include any amendments that may have been published since the Standard was published.

Detailed information about Australian Standards, drafts, amendments and new projects can be found by visiting [www.standards.org.au](http://www.standards.org.au)

Standards Australia welcomes suggestions for improvements, and encourages readers to notify us immediately of any apparent inaccuracies or ambiguities. Contact us via email at [mail@standards.org.au](mailto:mail@standards.org.au), or write to Standards Australia, GPO Box 476, Sydney, NSW 2001.

---

AS 3745—2010  
(Incorporating Amendment Nos 1 and 2)

Australian Standard®

## Planning for emergencies in facilities

Accessed by UNIVERSITY OF NEWCASTLE on 14 Oct 2019 (Document currency not guaranteed when printed)

Originated as AS 3745—1990.  
Previous edition 2002.  
Fourth edition 2010.  
Reissued incorporating Amendment No. 1 (May 2014).  
Reissued incorporating Amendment No. 2 (June 2018).

### **COPYRIGHT**

© Standards Australia Limited

All rights are reserved. No part of this work may be reproduced or copied in any form or by any means, electronic or mechanical, including photocopying, without the written permission of the publisher, unless otherwise permitted under the Copyright Act 1968.

Published by SAI Global Limited under licence from Standards Australia Limited, GPO Box 476, Sydney, NSW 2001, Australia

ISBN 978 0 7337 9727 9

## PREFACE

This Standard was prepared by the Standards Australia Committee FP-017, Emergency Management Procedures, to supersede AS 3745—2002, *Emergency control organization and procedures for buildings, structures and workplaces*.

*This Standard incorporates Amendment No. 1 (May 2014) and Amendment No. 2 (June 2018). The changes required by the Amendments are indicated in the text by a marginal bar and amendment number against the clause, note, table, figure or part thereof affected.*

The objective of this Standard is to enhance the safety of people in facilities, by providing a framework for emergency planning, utilizing the built facilities as appropriate.

The objective of this revision is to make a greater distinction between emergency plans and emergency/evacuation procedures. It also includes expanded and revised sections on—

- (a) developing the emergency plan;
- A1 | (b) the duties of the emergency planning committee (EPC) and emergency control organization (ECO);
- (c) provisions for occupants with a disability;
- (d) education and training; and
- (e) guidance on how to determine the size of the emergency control organization.

- A1 | Changes have been made to the indemnity clauses affecting members of both the EPC and the ECO.

Facility owners, managers, occupiers and employers should obtain professional advice on the level of indemnity provided to EPC and ECO members. The EPC and ECO members should be advised of the level of indemnity provided.

- A1 | Where AS 4083, *Planning for emergencies—Health care facilities*, is used in conjunction with this Standard, it should be noted that the nomenclature of the ECO personnel is different for patient or resident occupied areas.

Notes and examples integrated in the text of a document are used for giving additional information intended to assist the understanding or use of the document. These elements do not contain requirements or information considered indispensable for the use of the document.

The term 'informative' has been used in this Standard to define the application of the appendix to which it applies. An 'informative' appendix is only for information and guidance.

## CONTENTS

	<i>Page</i>
FOREWORD.....	5
SECTION 1 SCOPE AND GENERAL	
1.1 SCOPE.....	6
1.2 APPLICATION .....	6
1.3 NORMATIVE REFERENCES .....	7
1.4 DEFINITIONS.....	7
1.5 LIST OF ABBREVIATIONS .....	11
SECTION 2 EMERGENCY PLANNING COMMITTEE	
2.1 GENERAL.....	12
2.2 RESPONSIBILITIES.....	12
2.3 MEMBERSHIP.....	13
2.4 MEETINGS .....	14
2.5 INDEMNITY.....	14
SECTION 3 EMERGENCY PLAN	
3.1 GENERAL.....	15
3.2 EMERGENCY IDENTIFICATION AND ANALYSIS .....	15
3.3 KEY CONSIDERATIONS .....	16
3.4 STRUCTURE OF THE EMERGENCY PLAN .....	16
3.5 EVACUATION DIAGRAMS.....	18
3.6 DISTRIBUTION OF THE EMERGENCY PLAN.....	20
3.7 REVIEW AND AMENDMENT OF THE EMERGENCY PLAN.....	20
SECTION 4 EMERGENCY RESPONSE PROCEDURES	
4.1 GENERAL.....	21
4.2 KEY ELEMENTS AND CONSIDERATIONS FOR INCLUSION IN THE EMERGENCY RESPONSE PROCEDURES .....	21
4.3 EMERGENCY COLOUR CODES .....	26
SECTION 5 EMERGENCY CONTROL ORGANIZATION (ECO)	
5.1 GENERAL.....	27
5.2 POSITIONS ON THE ECO .....	27
5.3 NUMBER OF ECO MEMBERS .....	27
5.4 AUTHORITY .....	27
5.5 INDEMNITY.....	28
5.6 SELECTION CRITERIA FOR ECO MEMBERS.....	28
5.7 PRIMARY ROLES AND DUTIES.....	29
5.8 IDENTIFICATION.....	33
SECTION 6 TRAINING	
6.1 GENERAL.....	34
6.2 EPC TRAINING.....	34
6.3 ECO TRAINING .....	35
6.4 OCCUPANTS AND VISITORS.....	37
6.5 SKILLS RETENTION.....	37
6.6 COMMUNICATIONS SYSTEM .....	38
6.7 TRAINING MATERIALS.....	39

	<i>Page</i>
<b>SECTION 7 EMERGENCY RESPONSE EXERCISES</b>	
7.1 GENERAL.....	40
7.2 INITIAL TESTING AND IMPLEMENTATION .....	41
7.3 ONGOING PROGRAM .....	41
7.4 ECO BRIEFING .....	42
7.5 OBSERVERS' CHECKLIST.....	42
7.6 EMERGENCY RESPONSE EXERCISE DEBRIEFING SESSION .....	42
7.7 AN EMERGENCY DURING AN EMERGENCY RESPONSE EXERCISE .....	42
<b>SECTION 8 REVIEW AND ROUTINE SERVICING</b>	
8.1 EMERGENCY PLAN .....	43
8.2 COMMUNICATION SYSTEM.....	43
<b>APPENDICES</b>	
A FIRE AND SMOKE EMERGENCIES .....	44
B BOMB THREAT .....	45
C CIVIL DISORDER AND ILLEGAL OCCUPANCY .....	50
D EXAMPLE OF A PERSONAL EMERGENCY EVACUATION PLAN (PEEP) .....	52
E EXAMPLE EVACUATION DIAGRAMS .....	54
F GUIDANCE ON DETERMINING ECO NUMBERS.....	58
G EXAMPLE OF AN EMERGENCY EVACUATION EXERCISE OBSERVERS' CHECKLIST.....	60
H EXAMPLE OF A PHONE THREAT CHECKLIST .....	61
<b>BIBLIOGRAPHY</b> .....	<b>63</b>

## FOREWORD

The development and implementation of emergency plans and procedures are essential for the effective and efficient management of any emergency in a facility.

The requirements and recommendations in this Standard have been kept general so that they can be adapted to suit most facilities. Regardless of size and complexity of a facility, continual effort is needed to ensure that the arrangements are effective in an emergency.

All occupants and visitors regardless of their abilities have some obligation to take responsibility for their own safety and prepare a plan for evacuation during an emergency.

This Standard concerns emergency planning at the level of individual facilities. The emergency plan created using this Standard may form part of higher level emergency management or disaster management plan.

This Standard applies only to the human/life safety aspects of emergencies within facilities. Organizations may be assisted by taking into account how their emergency planning interacts with their other internal organizational strategies. These include the relationship between security and emergencies, management of different types of risk, and the business resilience of an organization following an emergency or disaster.

Standards Australia has published a range of Standards and Handbooks that may provide assistance in developing an understanding of the broader context in which emergency procedures may function. These include:

AS/NZS ISO 31000, *Risk management—Principles and guidelines*

AS/NZS 5050, *Business continuity—Managing disruption-related risk*

A1 | AS 4421, *Guard and patrol security services*

AS 3806, *Compliance programs*

HB 327, *Communicating and consulting about risk*

HB 293, *Executive guide to business continuity management*

HB 292, *A practitioner's guide to business continuity management*

HB 167, *Security risk management*

STANDARDS AUSTRALIA  

---

**Australian Standard**  
**Planning for emergencies in facilities**  

---

SECTION 1 SCOPE AND GENERAL

**1.1 SCOPE**

This Standard outlines the minimum requirements for the establishment, validation and implementation of an emergency plan for a facility to provide for the safety of occupants of that facility and its visitors leading up to, and during an evacuation.

It includes the following:

- (a) The formation, purpose, responsibility and training of the emergency planning committee.
- (b) Emergency identification.
- (c) The development of an emergency plan.
- (d) The development of emergency response procedures.
- (e) The establishment, authority and training of an emergency control organization.
- (f) The testing and validation of emergency response procedures.
- (g) Emergency related training.

This Standard does not cover facility operational incidents, community disaster management, business continuity, security management or major environmental impacts beyond the facility.

NOTES:

- 1 Guidance on planning and response for fire and smoke emergencies is given in Appendix A.
- 2 Guidance on planning and response for bomb threat is given in Appendix B.
- 3 Guidance on planning and response for civil disorder and illegal occupancy is given in Appendix C.
- 4 The information and guidance in Appendices A, B and C is not comprehensive enough to adequately plan for fire and smoke emergencies, bomb threat, and civil disorder and illegal occupancy.

**1.2 APPLICATION**

This Standard applies to buildings, structures or workplaces occupied by people, with the exception of Class 1a buildings as defined in the Building Code of Australia, unless that dwelling is also used as a workplace.

This Standard does not attempt to over-ride legislative obligations in providing for the safety of occupants and visitors in facilities.

It does, however, provide guidance for the planning and implementation of effective emergency planning committee (EPC) and emergency control organization (ECO) procedures, covering emergency situations up until the appropriate Emergency Service arrives to manage the situation, at which time, the ECO shall work in conjunction with that service.

The emergencies referred to in this Standard do not exclusively represent the likely range of emergencies that may occur in a facility. The range of specific emergencies shall be identified for each facility.

### 1.3 NORMATIVE REFERENCES

The following are the normative documents referenced in this Standard:

NOTE: Documents referenced for informative purposes are listed in the Bibliography.

AS

2700 Colour Standards for general purposes

AS/NZS

1841 Portable fire extinguishers

1841.1 Part 1: General requirements

Australian Bomb Data Centre, Bombs, Defusing the Threat

A1 | National Construction Code (NCC)

Commonwealth *Disability Discrimination Act 1992* (DDA)

### 1.4 DEFINITIONS

For the purpose of this Standard, the definitions below apply.

#### 1.4.1 Assembly area(s)

The designated place or places where people assemble during the course of an evacuation.

#### 1.4.2 Bomb

A device of any size or shape, which can look obvious or be camouflaged, may vary in its sophistication, and may not necessarily explode (i.e. incendiaries, toxic/noxious substances, sharps, animals/reptiles). May be referred to as an improvised explosive device (IED).

NOTE: Specific types of bombs are described in Appendix B, Paragraph B8.

#### 1.4.3 Bomb threat

A threat, written or verbal, delivered by electronic, oral, or other medium, threatening to place or use an explosive, chemical, biological, or radiological device at a time, date, place or against a specific person or organization. It is not necessary for any other action to be taken by the offender.

#### 1.4.4 Class 1a buildings

A single dwelling being—

- (a) a detached house; or
- (b) one of a group of two or more attached dwellings, each being a building, separated by a fire-resisting wall, including a row house, terrace house, town house or villa unit.

NOTE: This definition is taken from the Building Code of Australia.

#### 1.4.5 Competent person

A person who has acquired through training, education, qualification, experience, or a combination of these, the knowledge and skill enabling him/her to correctly perform the required task.

#### 1.4.6 Emergency

An event that arises internally, or from external sources, which may adversely affect the occupants or visitors in a facility, and which requires an immediate response.

**1.4.7 Emergency control organization (ECO)**

A person or persons appointed by the emergency planning committee to direct and control the implementation of the facility's emergency response procedures.

**1.4.8 Emergency mitigation**

Measures taken to decrease the likelihood of emergencies occurring and the associated impacts on people, the facility and the environment.

**1.4.9 Emergency plan**

The written documentation of the emergency arrangements for a facility, generally made during the planning process. It consists of the preparedness, prevention and response activities and includes the agreed emergency roles, responsibilities, strategies, systems and arrangements.

**1.4.10 Emergency planning committee (EPC)**

Persons responsible for the documentation and maintenance of an emergency plan.

A1

**1.4.10A Emergency planning consultant**

A person who has acquired through training, education, qualification and experience the knowledge and skill enabling him/her to advise on human behaviour, fire safety systems, evacuation methodology, emergency preparedness and response and the development of an emergency plan.

**1.4.11 Emergency preparedness**

The arrangements made to ensure that, should an emergency occur, all those resources and services that are needed to cope with the effects can be efficiently mobilized and deployed.

NOTE: Examples of emergency preparedness are: the membership, structure and duties of the EPC; emergency identification; the appointment of an ECO; development and maintenance of emergency procedures; training; organizing the temporary removal of people and property from a threatened location; facilitating timely and effective rescue.

**1.4.12 Emergency prevention**

The measures taken to eliminate the incidence of emergencies. These include the regulatory and physical measures to ensure that emergencies are prevented.

NOTE: Examples of emergency prevention are the implementation of suitable policies and procedures, regular maintenance and servicing of appliances, alarm systems, plant and equipment; training in the safe use of installed equipment; correct storage practices; good house keeping measures such as the reduction or removal of excessive fuel loads.

**1.4.13 Emergency response exercise**

A site-specific exercise implemented to determine the effectiveness of the emergency response procedures.

**1.4.14 Emergency response procedures**

A documented scheme of assigned responsibilities, actions and procedures within a designated section of the emergency plan, to respond to and manage emergencies.

A2

**1.4.14A Emergency Service(s)**

The State or Territory authority responsible for emergency response or recovery.

**1.4.15 Emergency response team (ERT)**

Specialist personnel, appointed to attend specific incidents, to contain, control or eliminate the emergency using emergency response equipment.

**1.4.16 Evacuation**

The orderly movement of people from a place of danger.

**1.4.17 Evacuation diagram**

Emergency and evacuation information about the facility, comprising a pictorial representation of a floor or area and other relevant emergency response information.

**1.4.18 Evacuation exercise**

An emergency response exercise in which the exercise simulates an emergency that requires an evacuation.

**1.4.19 Facility**

A building, structure or workplace that is, or may be, occupied by people (occupants).

NOTE: See also 'workplace' (Clause 1.4.34).

**1.4.20 Facility operational incidents**

Facility operational incidents are non-life threatening and may not require the activation of the ECO, e.g. computer failure, escalator failure, blocked toilets.

A2

**1.4.20A First-attack firefighting equipment**

Portable fire extinguishers, fire hose reels and fire blankets, which are used to fight fires in their early stages.

**1.4.20B First-response emergency equipment**

Resources, such as automatic external defibrillators (AEDs), spill kits and first aid kits, which are used to address various emergency scenarios in their early stages.

**1.4.21 May**

Indicates the existence of an option.

**1.4.22 Occupant**

A person attending a facility on a permanent or temporary basis, such as an employee, contractor, student or resident, but not a visitor.

**1.4.23 Occupant warning equipment**

Systems and devices that operate to alert people within a facility to an emergency.

NOTES:

- 1 Examples of occupant warning equipment are emergency warning and intercommunication systems (EWIS), sound systems for emergency purposes (s.s.e.p.), smoke alarms, pagers, visual warning systems including strobe lights, hand-held alarm devices, and intercom systems.
- 2 Occupant warning equipment may operate as part of a fire detection and alarm system and may function in conjunction with other emergency detection systems, such as those for storms, earthquakes and bomb threats.

**1.4.24 Occupant/visitor with a disability**

A person who requires—

- (a) more time or different forms of communication, compared with other occupants, to respond to an emergency; or
- (b) assistance to respond to an emergency or evacuate from a facility.

For further information see Clause 4.2.11.

## NOTES:

- 1 The definition above is taken from the *Commonwealth Disability Discrimination Act 1992* (DDA).
- 2 'Disability' includes but is not limited to the meaning given in Section 4.(1), sub-sections (a) to (h) for 'Disability', within the *Commonwealth Disability Discrimination Act 1992* (DDA).
- 3 'Occupant/visitor with a disability' also includes an associate of a person with a disability as defined in the DDA, or a companion animal.

**1.4.25 Personal emergency evacuation plan (PEEP)**

An individualized emergency plan designed for an occupant with a disability who may need assistance during an emergency.

**1.4.26 Refuge**

An area on a floor or area that is specifically designed to protect people from heat, smoke and toxic gases and which provides direct access to an exit.

## NOTES:

- 1 An area of refuge is intended to facilitate a safe delay in egress from the floor or area, thus constituting a space for people to await assistance for their evacuation.
- 2 Refuges are normally nominated by the relevant certifier.

**1.4.27 Shall**

Indicates that a statement is mandatory.

**1.4.28 Should**

Indicates a recommendation.

**1.4.29 Staging area**

An area in a facility where occupants and visitors are intended to gather in preparation for an evacuation.

**1.4.30 Structure**

- 1 A building (fixed or transportable), mast, tower, a steel or reinforced concrete construction, structural cable or telecommunications structure, underground works (including shafts and road, rail, telecommunications and interconnecting tunnels).
- 2 A railway line, airfield, dock or harbour, water storage or supply system, electricity or gas generation facility, transmission or distribution facility; or production, storage or distribution facilities for heavy industries; or fixed plant.

**1.4.31 Test**

Confirmation of correct function or performance of a component or system.

**1.4.32 Visitor**

A person who is within a facility who is temporarily visiting the facility and is not—

- (a) employed at or for the facility, either on a permanent casual, temporary, contracting basis;
- (b) a resident/inmate; or
- (c) studying at the facility.

NOTE: Visitors include customers and clients.

**1.4.33 Warden intercommunication point (WIP)**

The location on a floor or evacuation zone, that includes a handset provided through which instructions can be received from the intercommunication panel via the emergency intercom system.

#### 1.4.34 Workplace

Any place where work is, or is to be, performed by—

- (a) a person engaged for work for gain or reward, or on a voluntary basis;
- (b) a person conducting a business or undertaking; or
- (c) as defined by the relevant Commonwealth, State and Territory occupational health and safety statutes for the definition of 'workplace.'

NOTES:

- 1 See also 'facility' (Clause 1.4.19).
- 2 For example, offices, shops, factories, construction sites, stadiums and hospitals. It also includes many other types of less obvious workplaces, such as mines, underground tunnels, railway stations, care facilities, gaols, etc.

#### 1.5 LIST OF ABBREVIATIONS

The following abbreviations are used in this Standard or are commonly used in emergency planning literature:

ABDC	Australian Bomb Data Centre
AS	Australian Standard
AS/NZS	Joint Australian/New Zealand Standard
BCA	Building Code of Australia
DDA	Commonwealth <i>Disability Discrimination Act 1992</i>
ECO	emergency control organization
ECP	emergency call point (white)
EPC	emergency planning committee
ERT	emergency response team
EWIS	emergency warning and intercommunication system
FIP	fire indicator panel
HB	handbook
IED	improvised explosive device
MCP	manual call point (red)
PA	public address system
PEEP	personal emergency evacuation plan
s.s.e.p.	sound system for emergency purposes
WIP	warden intercommunication point

## SECTION 2    EMERGENCY PLANNING COMMITTEE

### 2.1 GENERAL

An emergency planning committee (EPC) shall be formed for each facility by the person or persons responsible for the facility or its occupants and visitors. Depending on the nature of the particular facility(ies), the EPC may be formed either for an individual facility, or group of facilities. The EPC shall be appropriate for the particular facility(ies).

Those responsible for a facility or its occupants shall ensure that the EPC has adequate resources to enable the development and implementation of the emergency plan.

#### NOTES:

- 1 The EPC should ensure applicable legislative requirements are met.
- 2 Those responsible for a facility or its occupants should ensure that leases include obligations to participate in emergency activities, including evacuation exercises.
- 3 Resources include time, finance, equipment and personnel.
- 4 Building/facility owners, agents, occupiers, lessors, or employers are typically those responsible for a facility or its occupants.
- 5 Due to regulatory and other local factors, it may not be appropriate to form an EPC covering a group of facilities in different States/Territories.
- 6 The EPC should consider the need for appointment of specialist advice.

### 2.2 RESPONSIBILITIES

The EPC, where necessary in collaboration with facility owners, managers, occupiers and employers, shall be responsible for the development, implementation and maintenance of the emergency plan, emergency response procedures and related training. This may be undertaken in conjunction with relevant external organizations.

NOTE: If the EPC becomes aware of features of the facility that could jeopardize the evacuation of the occupants and visitors, the EPC should notify the persons responsible for the facility.

The duties of the EPC shall include the following:

- (a) Identifying events that could reasonably produce emergency situations.
- (b) Developing an emergency plan in accordance with Section 3.
- (c) Ensuring that resources are provided to enable the development and implementation of the emergency plan.  
NOTE: Resources include time, finance, equipment and personnel.
- (d) Nominating the validity period for the emergency plan and the evacuation diagram.  
NOTE: The validity period should not exceed 5 years but may be less than 5 yearly, depending on the requirements of a maintenance cycle, a major change to the facility or an accreditation regime.
- (e) Ensuring that the emergency plan is readily identifiable and available to the appropriate persons.
- (f) Establishing an emergency control organization (ECO) to operate in accordance with the emergency plan.
- (g) If deemed necessary, establishing a specialist emergency response team (ERT).

- (h) Authorizing, or having authorized, the release and implementation of the emergency plan. The following shall apply to the implementation process:
- (i) *Awareness of the emergency response procedures* Information about the procedures shall be disseminated to occupants. The information shall be in a suitable format.  
NOTE: Suitable formats are listed in Clause 6.7.
  - (ii) *Training* A formalized training schedule shall be developed to ensure that relevant training is provided to ECO members and facility occupants. The training program shall be based on the emergency response procedures and be in accordance with Section 6.
  - (iii) *Testing the emergency procedures* The EPC should ensure that the emergency procedures are tested in accordance with Clause 7.2.
  - (iv) *Review of procedures* The effect of the procedures on an organization should be monitored at all stages of the implementation process. Amendments shall be made to rectify any deficiencies or inaccuracies that are identified in the procedures.
- (i) Establishing arrangements to ensure the continuing operation of the ECO.  
NOTE: For example, resignation, holidays, training of deputies, etc.
  - (j) Ensuring that the register of ECO members is current and readily available.
  - (k) Establishing strategies to ensure visitors are made aware of emergency response procedures.
  - (l) Ensuring that the emergency response procedures remain viable and effective by reviewing, and testing the emergency response procedures at least annually.
  - (m) Ensuring that the emergency plan is reviewed at the end of the validity period, after an emergency, an exercise, or any changes that affect the emergency plan.
  - (n) Ensuring that a permanent record of events for each emergency is compiled and retained.
  - (o) Identifying and rectifying deficiencies and opportunities for improvement in the emergency plan and emergency response procedures.

### 2.3 MEMBERSHIP

The EPC shall consist of not less than two people who shall be representative of the stakeholders in a facility one of which shall be management, unless the facility is owned or occupied and operated by a single person, in which case the EPC may be the sole person who is the owner/occupant.

At least one member of the EPC shall be a competent person (as defined in Clause 1.4.5).

#### NOTES:

- 1 In most facilities, the EPC would comprise senior management, tenants, chief warden and specialist facility personnel, such as the maintenance engineer and, where reasonably available, an occupant with a disability. The effectiveness of an emergency planning committee with respect to all occupants includes the extent to which it provides for occupants with a disability.
- 2 External contractors, consultants or others engaged by the facility to provide specialist advice should not be members of the EPC but may attend EPC meetings.

## 2.4 MEETINGS

The EPC shall meet at least annually.

A record of EPC meetings shall be made and retained in accordance with the relevant legislative requirements.

NOTE: This may include minutes of meetings, communication, financial position, reports and specialist advice.

## 2.5 INDEMNITY

Facility owners, managers, occupiers and employers should obtain professional advice on the level of indemnity provided to EPC members. The EPC members should be advised of the level of indemnity provided.

## SECTION 3 EMERGENCY PLAN

### 3.1 GENERAL

An emergency plan shall be developed and maintained for each facility.

The emergency plan shall document the organizational arrangements, systems, strategies and procedures relating to the response and management of emergencies. The EPC in collaboration with the facility owners, managers, occupiers and employers shall determine which types of emergencies warrant specific emergency response procedures within the emergency plan (see Clause 3.2).

A1 | The EPC, in collaboration with the ECO, the management of the facility and nominated staff shall participate in the implementation and maintenance of the emergency plan, as appropriate to their role within the organization.

Maintenance and review of the emergency plan shall be in accordance with Section 8.

#### NOTES:

- 1 Advisors for the emergency planning process should hold recognized qualifications/competencies in a relevant discipline.
- 2 Where security officers occupy or are engaged by a facility, their security operating procedures/site instructions should reflect, and be consistent with the emergency plan.
- 3 The EPC should consider its emergency plan in conjunction with all emergency plans/procedures developed by neighbouring facilities and other relevant agencies, for example, local municipal council and Emergency Services. The use and location of the facility may determine how the EPC will integrate its procedures with those developed by other agencies.
- 4 Consideration should be given to developing the emergency plan in conjunction with appropriate specialist advice, including advice on provisions for occupants with a disability.

The emergency plan shall include, but not be limited to, the following:

- (a) Emergency prevention (see Clause 1.4.12).
- (b) Emergency preparedness (see Clause 1.4.11).
- (c) Emergency mitigation (see Clause 1.4.8).
- (d) Activities for preparing for, and prevention of emergencies, such as training, and maintenance.
- (e) Overall control and coordination arrangements for emergency response (see Section 4). This shall include evacuation strategies for occupants with a disability.
- (f) The agreed roles and responsibilities of the emergency control organization and occupants of the facility in preparation for, during and after an emergency.

### 3.2 EMERGENCY IDENTIFICATION AND ANALYSIS

Identification and analysis of potential emergencies likely to impact on the facility shall be undertaken for each individual facility to determine which events require consideration as emergencies in the emergency plan.

The emergency identification and analysis shall include the following:

- (a) Identifying specific emergency events and scenarios that might affect the people in a facility.

NOTES:

1 This should include emergency events and scenarios arising from sources—

- (a) internal to the facility;
- (b) external to the facility; and
- (c) within the facility that affect other facilities.

2 The following are examples of types of emergencies to be considered:

- (a) *Human* Bomb; bomb threat; building invasion/armed intrusion; personal threat; chemical, biological and radiological/nuclear incidents; civil disorder; medical emergency; arson, explosion; suspect object.
- (b) *Natural* Bushfire/grass fire; cyclones, including storm surge; earthquake; explosion; fire and smoke; flood; severe weather/storm damage.
- (c) *Technological* Hazardous substances incidents; industrial incidents; structural instability; transport incidents; toxic emissions.

- (b) Identifying the possible consequences of each emergency to people within the facility and their vulnerability before, during and after the emergency.

- (c) After following the steps(a) and (b) above, deciding which types of potential emergencies are to be included in the emergency plan.

Potential emergencies for inclusion in the emergency plan may also be identified from documentation such as fire safety engineers' reports, fire safety plans, other safety reports and risk assessment reports.

### 3.3 KEY CONSIDERATIONS

In identifying potential emergencies and developing and maintaining the emergency plan, the following shall be taken into account:

- (a) The size and complexity of the facility.
- (b) Fire engineered or life safety features of the facility.

NOTE: The regulatory approval process, fire engineering reports, occupant evacuation analyses, fire safety plans and other building reports should be used to determine the fire engineered or life safety features of the facility.

- (c) Security systems, procedures and protocols.
- (d) The number and nature of occupants and visitors.
- (e) The hours of occupancy.

### 3.4 STRUCTURE OF THE EMERGENCY PLAN

The emergency plan shall include, but not be limited to, the following elements:

- (a) A clear statement of purpose and scope.
- (b) Information on the structure and purpose of the EPC.
- (c) Identification of the facilities to which it applies.
- (d) Descriptions of the emergency features (safety, fire and security) of the facility.
- (e) The organisational arrangements for the facility.

- (f) Separate sections for the following:
- (i) The emergency identification outcomes.
  - (ii) The emergency response procedures, in accordance with Section 4.
  - (iii) The evacuation diagram, in accordance with Clause 3.5.
  - (iv) Training arrangements, in accordance with Section 6.
  - (v) Emergency response exercises, in accordance with Section 7.
  - (vi) Review and routine servicing, in accordance with Section 8.
- (g) A statement of the extent of distribution of the emergency plan or excerpts from the emergency plan.
- (h) A record of distribution, including where personal emergency evacuation plans (PEEPs) for people with disabilities are held. For example PEEPs should be held by the relevant warden.
- (i) Details of the hours of occupancy of the facility.
- (j) The EPC nominated validity period for the emergency plan.
- (k) The date of issue or amendment date on each page of the emergency plan.

If an electronic format is used for the emergency plan, at least one printed copy shall be available on site.

NOTE: Figure 3.1 provides a representation of the broad structure of an emergency plan.

A1  
A2



FIGURE 3.1 STRUCTURE OF THE EMERGENCY PLAN

## 3.5 EVACUATION DIAGRAMS

### 3.5.1 General

Evacuation diagrams that provide emergency and evacuation information shall be displayed in all facilities in accordance with Clauses 3.5.2, 3.5.3, 3.5.4 and 3.5.5.

- A2 | Where emergency and evacuation information is included on the evacuation diagram, this information shall reflect the facility emergency and evacuation information as documented in the emergency plan.

NOTES:

- A1 | 1 Optional elements of the evacuation diagram are given in Clause 3.5.6.
- A1 | 2 Examples of evacuation diagrams and symbols are shown in Appendix E.
- A1 | 3 Where emergency and evacuation information is included on the evacuation diagram, this information should reflect the facility emergency and evacuation information as documented in the emergency plan.
- A2 | 4 For facilities with larger floor areas such as hospitals, tunnels, large office floors, warehouses, universities, shopping centres, etc., the pictorial representation should be prepared in sections or areas so that no more than two exits are shown on each pictorial representation.

### 3.5.2 Number and location

Evacuation diagrams shall be displayed in locations where occupants and visitors are able to view the diagrams. The location within the facility and number of evacuation diagrams shall be determined by the EPC.

- A2 | NOTE: Evacuation diagrams should not be fitted to fire doors, smoke doors or other fire resistant elements of construction unless this has been tested or a formal opinion has been obtained from an appropriate authority (e.g. a testing laboratory or professional engineer).

### 3.5.3 Position

- A2 | The evacuation diagram should be positioned with the bottom edge of the diagram at a height not less than 1200 mm or the top edge not more than 1600 mm above the plane of the finished floor.

### 3.5.4 Orientation

Individual evacuation diagrams shall have the correct orientation with regard to the direction of egress and its location to the 'YOU ARE HERE' point. Where an assembly area diagram is included, the assembly diagram area shall have the same orientation to the rest of the diagram.

### 3.5.5 Minimum elements

The following shall be included in each evacuation diagram:

- A1 | (a) A pictorial representation of the floor or area.
- A2 | NOTE: External elements, such as fences, roads, landscaping, external buildings, etc., should be excluded from the pictorial representation unless part of the exit pathway.
- (b) The title 'EVACUATION DIAGRAM'.
- (c) The 'YOU ARE HERE' location.
- (d) The designated exits in the facility, which shall be green.
- (e) The following communications equipment, where installed:
- (i) Warden intercommunication points (WIPs), which shall be red.
- A2 | (ii) Manual call points (MCPs), which shall be red, and emergency call points (ECPs), which shall be white with a black border.
- (iii) Main controls/panels for the occupant warning equipment.

- (f) Hose reels, which shall be red.
- A1 | (g) **'Text deleted'**
- (h) Extinguishers, which shall be red with an additional appropriate colour as specified in AS/NZS 1841.1.
- A2 | (i) Fire blankets, which shall be red.
- (j) Fire indicator panel (FIP), if provided.
- (k) Refuges, if present.
- (l) Validity date.
- (m) Location of assembly area(s), either stated in words or pictorially represented.
- (n) A legend, which shall reflect the symbols used.
- A2 | (o) Paths of travel, which shall be green.
- (p) Location of facility, including address, postcode, location of access street(s), nearest cross street and name of facility (if available), either stated in words or pictorially represented.

### 3.5.6 Optional elements

The following additional information may be considered by the EPC for inclusion on the evacuation diagram:

- (a) Direction of opening of doors on designated exits.
- (b) North.
- (c) First aid stations and kits (denoted by a white cross on a green background).
- (d) Hazardous chemical store.
- (e) Spill response kits.
- A1 | (f) Emergency information as documented in the emergency plan.
- A2 | NOTE: For example, emergency telephone numbers, emergency response procedures, fire orders, and procedures for use of lifts in an evacuation during a fire emergency (where regulatory approval has been obtained).
- (g) **'Text deleted'**
- (h) Specialized evacuation devices, including stairwell evacuation devices, if provided.
- (i) Fire and smoke doors.
- (j) Hydrants, which shall be red.
- A2 | (k) Automatic external defibrillator(s) (AED).
- (l) Electrical switchboard location(s).
- (m) Solar power isolation point(s).

### 3.5.7 Size

#### A1 | 3.5.7.1 Diagram with only minimum elements

The minimum size of the evacuation diagram shall be A4 (i.e. 210 mm × 297 mm) with a pictorial representation of the floor or area, which shall be as a minimum—

- (a) 200 mm × 150 mm; or
- (b) an area of 30 000 mm<sup>2</sup>.

A1 | **3.5.7.2** *Diagram with minimum and optional elements*

The minimum size of the evacuation diagram shall be A3 (i.e. 297 mm × 420 mm) with a pictorial representation of the floor or area, which shall be as a minimum—

- (a) 300 mm × 200 mm; or
- (b) an area of 60 000 mm<sup>2</sup>.

**3.6 DISTRIBUTION OF THE EMERGENCY PLAN**

The emergency plan shall be distributed to members of the EPC. As a minimum, distribution of sections within the emergency plan shall comply with the following:

- (a) Sufficient information from the emergency response procedures shall be distributed to members of the ECO to enable them to carry out their required duties.
- (b) Sufficient information from the emergency response procedures shall be distributed to facility occupants to explain the actions they are to take with regard to an emergency.
- (c) The evacuation diagram shall be displayed in the facility, in accordance with Clause 3.5.
- (d) The information shall be distributed in an appropriate format that can be comprehended by the recipient.

NOTE: Examples of formats are listed in Clause 6.7.

The EPC shall determine whether any additional distribution is needed.

A1 | **'Text and Figure deleted'**

**3.7 REVIEW AND AMENDMENT OF THE EMERGENCY PLAN**

A1 | The emergency plan should be routinely serviced in accordance with Section 8.

## SECTION 4 EMERGENCY RESPONSE PROCEDURES

### 4.1 GENERAL

- A1 | An emergency response procedure for each emergency identified in accordance with Clause 3.2 shall be developed for all facilities addressing the following:
- (a) Responsibilities and duties of the ECO and the actions they are to take during an emergency, including those roles and duties set out in Clause 5.7.
  - (b) The responsibilities of facility occupants and the actions they are to take in an emergency.
  - A1 | (c) The arrangements for emergency preparedness and response.
  - (d) The arrangements for evacuating the facility.
  - (e) The current emergency contact details.

### 4.2 KEY ELEMENTS AND CONSIDERATIONS FOR INCLUSION IN THE EMERGENCY RESPONSE PROCEDURES

#### 4.2.1 General

The specific information included in the emergency response procedures shall be determined by the EPC in collaboration with the facility owners, managers, occupiers and employers in accordance with this Clause (4.2). The EPC shall also determine any other information that is to be included, as appropriate to each specific facility.

##### NOTES:

- 1 Several key elements and considerations to be taken into account by the EPC when developing and maintaining the emergency response procedures are listed in this Clause however the list is not exhaustive.
- 2 The list is arranged in alphabetical order.
- A1 | 3 **'Note deleted'**

#### 4.2.2 After-hours procedures

The specific needs of people who may be present outside the normal hours of business/operation shall be considered.

#### 4.2.3 Communication

##### 4.2.3.1 *Communicating the emergency*

The emergency procedures shall address the method of warning and communication to be used during an emergency.

The needs of occupants and visitors with a disability shall be considered when developing procedures for emergency warning. This may entail alternative means of communicating emergency information and warnings.

##### 4.2.3.2 *Neighbouring facilities*

Consideration should be given to communications with neighbouring facilities.

#### 4.2.3.3 Communications equipment

For continuity of communications in an emergency, consideration shall be given to the following:

- (a) The utilization of multi-modal communication systems for emergency responses.  
NOTE: Multi-modal communication systems are intended to ensure continuity of communication in the event of the failure of the primary communication system. Examples are—
  - (a) s.s.e.p (e.g., EWIS);
  - (b) visual and tactile signals;
  - (c) telephones (including mobile and satellite telephones);
  - (d) two-way radio;
  - (e) paging systems;
  - (f) public address systems; and
  - (g) runners.
- (b) The limitations of transmitting equipment technology in certain types of emergencies.
- (c) The potential effects of using equipment producing electromagnetic radiation in situations where such signals could have adverse effects on explosive devices or essential equipment, such as sensitive medical equipment, that may be in the same location.  
NOTE: Equipment producing electromagnetic radiation includes mobile phones, radio sets and appliances using wireless technology transmission.
- (d) Any battery-powered equipment that needs fully charged batteries available.
- (e) The potential failure of equipment that is mains-powered without battery backup.

#### 4.2.4 Control and coordination

The procedures should identify an appropriate location from which the chief warden can establish control, communication and coordination, and liaise with the Emergency Services.

NOTE: This is sometimes referred to as the 'emergency control point'.

An alternative location(s) should be nominated in the emergency response procedures to allow for contingencies.

#### 4.2.5 Emergency response equipment

A2 | The procedures should include appropriate information and instructions on the use of any first-attack firefighting equipment and first-response emergency equipment that is in place in a facility.

NOTE: [Text deleted].

#### 4.2.6 Evacuation

##### 4.2.6.1 General

The emergency response procedures shall address the actions that are to be taken to evacuate the facility by members of the ECO, occupants and visitors.

NOTE: As appropriate to the facility, the emergency response procedures should include requirements that the ECO members—

- (a) check their area of responsibility to determine whether all persons have been evacuated; and
- (b) report the result of the check to the chief warden, including whether any refuge is occupied.

This function is of greater importance than a later physical count of those evacuated.

#### 4.2.6.2 Occupants and visitors with a disability

The evacuation arrangements for persons with a disability shall be considered in the development of the emergency response procedures.

#### 4.2.6.3 Evacuation options

The procedures shall address the extent of evacuation from a facility that is necessary for different types of emergencies. Consideration shall be given to the following evacuation options, as appropriate to the facility:

- (a) *Full evacuation* This measure is used to clear a building or facility of all occupants (see Notes 1 and 2).
- (b) *Partial evacuation* This measure is an alternative to a total evacuation in some buildings such as hospitals, aged care facilities and multi-storey buildings.

NOTE: Partial evacuation may—

- (a) include evacuation into or through smoke and fire compartments;
- (b) be used to evacuate individuals closest to a situation and to prevent congestion in the stairways; or
- (c) be utilized when evacuation of several floors is sufficient to protect occupants while the hazard is being eliminated, i.e., to move people away from a localized emergency within a building or facility (see Note 3).

- (c) *Shelter in place (no evacuation)* This measure is an emergency response option that allows occupants and visitors to remain inside a facility on the basis that an evacuation to an external-to-building location might reasonably expose evacuating people to a greater level of danger.

NOTE: Shelter in place (no evacuation) may be the appropriate option in response to threats to safety, such as lightning storms, severe storms, floods, dust, smoke from adjacent structures, bushfires or grass fires, air-borne toxic agents, gas leaks or dangerous animals.

- (d) *Escape, Hide, Tell* Where immediate escape from the facility is not considered personally safe, then occupants should hide out of sight and remain silent, or alternatively take other action to protect their safety.

NOTE: For further assistance and the latest information about the Escape, Hide, Tell methodology, see the Australian National Security website ([www.nationalsecurity.gov.au](http://www.nationalsecurity.gov.au)) to access the Australian-New Zealand Counter-Terrorism Committee publication, *Active Armed Offender Guidelines for Crowded Places*.

- (e) *Lockdown* The process of securing a facility (full or partial) or an area to protect its occupants in response to an occurring or imminent threat that may have the potential to cause harm.

An assessment of the shelter or refuge to determine the suitability and sustainability of the shelter should be carried out for certain emergencies, where shelter in place option is being considered.

The success of this strategy will depend, to a large extent, on the degree to which premises have been prepared. The most appropriate decision will be made after the assessment of all the available information. Decision-makers should seek and evaluate expert advice (see Note 4).

NOTES:

- 1 Full evacuation would normally be carried out in response to a potentially catastrophic, life-threatening situation or where the building cannot function due to a severe services malfunction.
- 2 In some buildings, the alarm system is automatically set to the evacuate tone without utilizing an alert tone facility. Emergency response procedures should reflect these situations.

- 3 Examples of where a partial building evacuation may be carried out include a localized fire, a localized flood, a chemical spill, or a bomb threat specified for a certain area.
- 4 Numerous situations can occur that make it advisable for those inside a building to remain inside for their own protection. These procedures may be warranted if, for example, an industrial strike action that is taking place outside the building turns violent.

#### 4.2.6.4 *Evacuation routes*

The likely effect that a particular emergency may have on evacuation routes and normal paths for leaving the facility shall be considered.

#### 4.2.6.5 *Assembly area(s)*

Assembly areas shall, so far as is reasonably practicable, be sufficiently distant from the emergency for the protection of evacuees.

##### NOTES:

- 1 Ideally the areas selected should be sheltered from the affected facility and should allow for further movement away from the emergency. Consideration should be given to dangers such as smoke and flying/falling debris and other objects.
- 2 An assembly area should be accessible by a route suitable for people who walk with difficulty or use mobility aids, including walking frames and wheelchairs, and prams.
- 3 The movement of large numbers of people has its inherent dangers, particularly in heavy traffic. Careful thought should be given to determine the safest routes from the facility to the nominated places of assembly, including alternatives, and to ensure access for emergency vehicles is not hindered.
- 4 Evacuation may be to another nominated internal or external area, such as another floor or refuge.
- 5 Alternative assembly area(s) may be necessary if the nominated assembly area is unsuitable.

#### 4.2.7 **External sources**

The characteristics of, and hazards from, external sources shall be considered.

#### 4.2.8 **First aid officers**

Where first aid officers exist, their duties during an emergency should be considered by the EPC.

The roles of the first aid officers and wardens should be separate and distinct.

#### 4.2.9 **Lifts and escalators**

Lifts and escalators should not be relied upon as a means of evacuation from fire unless their suitability for that purpose has been nominated through a regulatory approval process.

NOTE: Lifts and escalators may be appropriate for use in other types of emergencies and in some circumstances, particularly in emergencies other than fire.

- A1 | In developing the regulatory approval, a team including a fire safety engineer, a mechanical services engineer, a lift engineer, an emergency planning consultant and an access consultant should jointly produce a strategy document that would be both part of the documentary evidence and of the emergency plan.

#### 4.2.10 **Media response**

Restrictions should be placed on contacting print or electronic media during the emergency. All media statements should be provided, released and authorized by nominated persons.

#### 4.2.11 **Occupants and visitors with a disability**

When developing emergency response procedures, consideration shall be given to occupants and visitors who for one reason or another may need assistance or are unlikely to be able to act optimally in an emergency. This would include but not be limited to occupants and visitors who—

- A1
- (a) are accompanied by an assistant;
  - (b) have a guide or companion animal;
  - (c) use alternative forms of information and communication;
  - (d) have a vision impairment;
  - (e) have a hearing impairment;
  - (f) have an ambulatory impairment;
  - (g) use a wheeled mobility appliance, including wheelchair or scooter;
  - (h) are easily fatigued;
  - (i) easily experience acute anxiety in an emergency; or
  - (j) easily experience extreme confusion in an emergency.

NOTES:

- 1 A current list of the names, workplaces and other necessary information about occupants with a disability should be kept at the locations where the chief warden exercises control.
- 2 Suitable strategies in an emergency or evacuation should be discussed with those occupants of the facility who have a disability and a personal emergency evacuation plan (PEEP) developed for each of those persons.
- 3 Should the use of lifts for evacuation during a fire emergency have regulatory approval, procedural information should be included in the PEEP.

Information on the PEEP shall be disseminated to all people responsible for its implementation.

NOTE: An example of a PEEP is given in Appendix D.

#### 4.2.12 Organization of the facility

The organizational arrangements for each facility shall be considered. This includes the human resources aspects of the facility's organization.

#### 4.2.13 People unfamiliar with the emergency response procedures

The needs of people who may be within a facility and are not familiar with the emergency response procedures shall be considered.

#### 4.2.14 Personal effects

When being evacuated, occupants and visitors may be asked to take their immediately available personal effects such as handbags, wallets and car keys if it is safe to do so.

#### 4.2.15 Refuges

Refuges are areas where occupants and visitors may wait for their delayed independent evacuation, or assisted evacuation by Emergency Services or other nominated personnel.

NOTE: Refuges are normally nominated by the relevant certifier.

Occupants who have a disability should be attended in the refuge by another person.

#### 4.2.16 Specialist staff

The roles of security guards, receptionists/switchboard operators and other specialist staff shall be considered.

#### 4.2.17 Stairway evacuation device

Consideration should be given to the use and suitability and storage arrangements of stairway evacuation devices for people who use wheelchairs or who otherwise would need to be carried down the stairway.

NOTE: Any stairway evacuation device should be operated by a competent person.

#### 4.2.18 Use and characteristics of the facility

The use and characteristics of each facility and the appropriateness and adequacy of physical facilities shall be considered. This includes the physical construction and layout as well as the type of activity that takes place within the facility.

#### 4.2.19 Vehicle entry points

Consideration shall be given to imposing restrictions on vehicular movement during an emergency.

##### NOTES:

- 1 Persons should be nominated by the chief warden to restrict vehicle movements into the facility.
- 2 Persons should be nominated by the chief warden to be at entry points to the facility to meet responding Emergency Service(s).

### 4.3 EMERGENCY COLOUR CODES

A standardized colour code for notification, identification and response activation may be used in the emergency response procedures:

- (a) Where colour codes are used for specific emergencies the colours should—
  - (i) be as shown in Column 2 of Table 4.1; and
  - (ii) approximate those listed in Table 4.1, either from AS 2700, or the colour settings for printing (see Notes 1, 2 and 3).
- (b) For the verbal 'all clear' notification, the relevant colour code shall be stated followed by the words 'ALL CLEAR'.

##### NOTES:

- 1 These colour codes are consistent with those used in AS 4083.
- 2 The correlations between the AS 2700 codes and the RGB and CMYK codes are approximations only.
- 3 CMYK values are highly device-dependent, therefore their values in Table 4.1 are not suitable for careful colour rendition.
- 4 The colour green is reserved for uses related to safety and first-aid.
- 5 Using colour codes other than those listed in Table 4.1 may lead to confusion.

**TABLE 4.1**  
**EMERGENCY COLOUR CODES**

Emergency	Colour	AS 2700 Code	Colour Settings for printing	
			RGB	CMYK
Fire and/or smoke	Red	R13	227, 66, 52	0, 71, 77, 11
Bomb threat	Purple	P12	128, 0, 128	66, 87, 0, 0
Medical emergency	Blue	B22	0, 47, 167	98, 84, 0, 0
Personal threat*	Black	N61	0, 0, 0	0, 0, 0, 100
Internal emergency†	Yellow	Y26	255, 215, 0	0, 16, 100, 0
External emergency	Brown	X54	150, 75, 0	0, 50, 100, 41
Evacuation	Orange	X13	255, 127, 0	0, 50, 100, 0

\* For example, armed or unarmed persons threatening injury to others or to themselves.

† For example, failure or threat to essential services.

## SECTION 5 EMERGENCY CONTROL ORGANIZATION (ECO)

### 5.1 GENERAL

The ECO shall be appropriate to the facility and to the emergency response procedures as determined by the EPC.

The titles of ‘chief warden’, ‘communications officer’, ‘floor warden’ or ‘area warden’ and ‘warden’ should be used when these positions are included in the ECO. Titles for other positions may be determined by the EPC.

### 5.2 POSITIONS ON THE ECO

The ECO shall consist of a chief warden or equivalent as a minimum. The following positions shall be included if they are deemed necessary by the EPC and in accordance with the requirements of this Standard:

- (a) Deputy chief warden.
- (b) Communications officer and deputy.
- (c) Floor/area wardens and deputies.
- (d) Wardens and deputies.

Other ECO positions may be incorporated into the ECO, for example, runners, stair wardens, roll call wardens, traffic wardens, section wardens.

An up-to-date register of all ECO members shall be kept readily available, with or via the chief warden.

### 5.3 NUMBER OF ECO MEMBERS

The number of ECO members shall be determined in accordance with—

- (a) the size of the facility, floor or area;
- (b) the number of occupants and visitors; and
- (c) the installed occupant warning equipment.
- (d) the fire engineered and life safety features of the facility.

The positions and number of ECO members shall be considered by the EPC.

#### NOTES:

- 1 Guidance on determining ECO numbers is given in Appendix F.
- 2 In single tenancies, the ECO may consist of one person, who would be the ‘chief warden’.

### 5.4 AUTHORITY

During emergencies, instructions given by the emergency control organization (ECO) personnel shall take precedence over the normal management structure.

#### NOTES:

- 1 Nothing in this clause is intended to over-ride or change the legislative responsibility of the facility owners, managers, occupiers and employers in ensuring the safety of all occupants and visitors to the facility.
- 2 Authority given to the ECO to act during an Emergency must be acknowledged by the facility owners, managers, occupiers and employers as part of the Emergency planning activities.

- 3 The EPC should ensure that the appropriate people, such as senior management, have been advised of the authority of the ECO during emergencies.
- 4 This authority is intended to ensure that, during an emergency situation, life safety takes precedence over asset protection, environmental considerations, production operations and business continuity.

## 5.5 INDEMNITY

Facility owners, managers, occupiers and employers should obtain professional advice on the level of indemnity provided to ECO members. The ECO members should be advised of the level of indemnity provided.

## 5.6 SELECTION CRITERIA FOR ECO MEMBERS

### 5.6.1 Chief warden

The person appointed as chief warden should—

- (a) be capable of performing their duties;
- (b) be capable of leading and taking command;
- (c) display effective decision-making skills;
- (d) demonstrate the capability to remain calm under pressure;
- (e) be available to undertake their appointed duties;
- (f) be capable of effectively communicating with occupants and visitors;
- (g) be familiar with the facility; and
- (h) be able to undergo relevant training.

### 5.6.2 Communications officer

The person appointed as communications officer should—

- (a) be capable of performing their duties;
- (b) display effective decision-making skills;
- (c) demonstrate the capability to remain calm under pressure;
- (d) be available on-site to undertake their appointed duties;
- (e) be capable of effectively communicating with occupants and visitors; and
- (f) be able to undergo relevant training.

### 5.6.3 Floor or area wardens

Floor or area wardens should be appointed consistent with the level of their day-to-day responsibilities.

The floor or area warden responsibilities should be attached to a specific position, to ensure where possible, that the person appointed to the position, in either a permanent or temporary capacity, carries out the necessary functions.

Persons appointed as floor/area wardens should—

- (a) be capable of performing their duties;
- (b) have leadership qualities and the ability to command authority;
- (c) display effective decision-making skills;
- (d) demonstrate the capability to remain calm under pressure;
- (e) be available on-site to undertake their appointed duties;

- (f) be capable of effectively communicating with occupants and visitors;
- (g) be capable of deputizing for other positions on the ECO; and
- (h) be able to undergo relevant training.

#### 5.6.4 Wardens

Persons appointed as wardens should—

- (a) be capable of performing their duties;
- (b) have leadership qualities and command authority;
- (c) be available to undertake their appointed duties;
- (d) be capable of communicating with occupants and visitors;
- (e) be capable of deputizing for other positions; and
- (f) be able to undergo relevant training.

#### 5.6.5 Deputies

The appointment of deputies shall be considered, to ensure the effective functioning of the ECO. Persons appointed as deputies shall have the same capabilities and personal attributes as required for the substantive position.

### 5.7 PRIMARY ROLES AND DUTIES

#### 5.7.1 General

The primary role of the ECO is to give top priority to the safety of the occupants and visitors of the facility during an emergency. Life safety shall take precedence over asset protection during an emergency.

The ECO should have clearly documented pre-emergency, emergency and post-emergency duties and responsibilities.

This Clause lists the duties of each member of the ECO, when it comprises the full range of roles. In cases, where the ECO does not include all of the roles defined in this Standard, the duties listed in Clauses 5.7.2 to 5.7.4 shall be addressed in the emergency response procedures and assigned to the existing ECO membership, as appropriate to the organizational structure of the facility.

#### 5.7.2 Pre-emergency

The actions to be undertaken by the ECO prior to an emergency event should be as set out in the emergency response procedures and may include the following:

- (a) *Chief warden:*
  - (i) Maintain a current register of ECO members.
  - (ii) Replace ECO members when a position becomes vacant.
  - (iii) Conduct regular exercises.
  - (iv) Ensure the emergency response procedures are kept up-to-date.
  - (v) Attend meetings of the EPC, as appropriate.
  - (vi) Attend training and emergency exercises, as required by the EPC.
  - (vii) Ensure personal ECO identification is available.

- (b) *Communications officer:*
- (i) Ensure personal proficiency in operation of facility communication equipment.
  - (ii) Maintain records and logbooks and make them available for emergency response.
  - (iii) Ensure that ECO members are proficient in use of the facility communication equipment.
  - (iv) Ensure that emergency communication contact details are up-to-date.
  - (v) Attend training and emergency exercises, as required by the EPC.
- (c) *Floor/area warden:*
- (i) Confirm sufficient wardens for area of responsibility.
  - (ii) Coordinate the completion of PEEP documentation.
  - (iii) Report on deficiencies of emergency equipment.
  - (iv) Ensure that wardens have communicated the emergency response procedures to all occupants within their nominated areas.
  - (v) Ensure that occupants are aware of the identity of their wardens.
  - (vi) Coordinate safety practices (e.g., clear egress paths, access to first-attack firefighting equipment and disposal of rubbish) by wardens throughout their area of responsibility.
  - (vii) Attend training and emergency exercises, as required by the EPC.
  - (viii) Ensure personal ECO identification is available.
- (d) *Wardens:*
- (i) Ensure that all occupants are aware of the emergency response procedures.
  - (ii) Carry out safety practices (e.g., clear egress paths, access to first-attack firefighting equipment and disposal of rubbish).
  - (iii) Ensure personal ECO identification is available.
  - (iv) Attend training and emergency exercises, as required by the EPC.
- (e) *Emergency response team:*
- (i) Attend regular training.
  - (ii) Practise use of specialized equipment.
  - (iii) Maintain specialised equipment as per manufacturers' specifications.  
NOTE: Examples of specialized equipment include spill-kits and breathing apparatus.
  - (iv) Ensure that personal protective equipment is maintained and available.
  - (v) Ensure personal ERT identification is available.
  - (vi) Pre-emergency planning.
  - (vii) Attend training and emergency exercises, as required by the EPC.

### 5.7.3 Emergency

The actions to be undertaken by the ECO in the event of an emergency shall include, but not be limited to, the following:

- A1 |
- (a) *Chief warden* On becoming aware of an emergency, the chief warden shall take the following actions:
    - (i) Respond and take control, as appropriate.
    - (ii) Ascertain the nature of the emergency and implement appropriate action.
    - (iii) Ensure that the appropriate Emergency Service has been notified.
    - (iv) Ensure that floor or area wardens are advised of the situation, as appropriate.
    - (v) If necessary, after evaluation of the situation, initiate an action plan in accordance with the emergency response procedures and control entry to the affected areas.
    - (vi) Monitor the progress of the evacuation and record any action taken in an incident log.
    - (vii) Brief the Emergency Services personnel upon arrival on type, scope and location of the emergency and the status of the evacuation and, thereafter, act on the senior officer's instructions.
    - (viii) Any other actions as considered to be necessary or as directed by Emergency Services.
  - (b) *Deputy chief warden* The deputy chief warden shall assume the responsibilities normally carried out by the chief warden if the chief warden is unavailable, and otherwise assist as required.
  - (c) *Communications officer* The communications officer, on becoming aware of the emergency, shall take the following actions:
    - (i) Ascertain the nature and location of the emergency.
    - (ii) Confirm that the appropriate Emergency Service has been notified.
    - (iii) Notify appropriate ECO members.
    - (iv) Transmit instructions and information.
    - (v) Record a log of the events that occurred during the emergency.
    - (vi) Act as directed by the chief warden.
  - (d) *Floor/area wardens* On hearing an alarm or on becoming aware of an emergency, the floor or area wardens shall take the following actions:
    - (i) Implement the emergency response procedures for their floor or area.
    - (ii) Ensure that the appropriate Emergency Service has been notified.
    - (iii) Direct wardens to check the floor or area for any abnormal situation.
    - (iv) Commence evacuation if the circumstances on their floor or area warrant this.
    - (v) Communicate with the chief warden by whatever means available and act on instructions.
    - (vi) Advise the chief warden as soon as possible of the circumstances and action taken.
    - (vii) Co-opt persons as required to assist a warden during an emergency.

- (viii) Confirm that the activities of wardens have been completed and report this to the chief warden or a senior officer of the attending Emergency Services if the Chief Warden is not contactable.
- (e) *Wardens* Persons selected as wardens shall carry out activities as set out in the emergency response procedures and as directed by the floor or area warden. Wardens' activities may include the following:
  - (i) Act as floor or area wardens.
  - (ii) Operate the communication system(s) in place.
  - (iii) Check that any fire doors and smoke doors are properly closed.
  - (iv) Close or open other doors in accordance with the emergency response procedures.
  - (v) Search the floor or area to ensure all people have evacuated. This function is of greater importance than a later physical count of those evacuated.
  - (vi) Ensure orderly flow of people into protected areas, for example, stairways.
  - (vii) Assist occupants with disabilities.
  - (viii) Act as leader of groups moving to nominated assembly areas.
  - (ix) Report status of required activities to the floor or area warden on their completion.
- (f) *Emergency response team* Members of the emergency response team shall carry out activities as set out in the emergency response procedures and the following:
  - (i) Respond to the emergency as directed by the chief warden.
  - (ii) Communicate the status of the situation with the chief warden.
  - (iii) Hand over and brief Emergency Services on arrival.

#### 5.7.4 Post-emergency

The actions to be undertaken by the ECO after an emergency should include, but not be limited to, the following:

- (a) *Chief warden:*
  - (i) When the emergency incident is rendered safe or the Emergency Service returns control, notify the ECO members to have occupants return to their facility, as appropriate.
  - (ii) Organize a debrief with ECO members and, where appropriate, with any attending Emergency Service.
  - (iii) Compile a report for the EPC and management.
- (b) *Communications officer* Collate records of events during the emergency for the debrief and ensure they are secured for future reference.
- (c) *Floor/area wardens and wardens* Compile a report of the actions taken during the emergency for the debrief.
- (d) *Emergency response team:*
  - (i) Clean and service used specialised equipment.
  - (ii) Replace specialized equipment as necessary.

NOTE: The re-entry and post emergency actions should be done in collaboration with the facility owners, managers, occupiers and employers.

### 5.8 IDENTIFICATION

The members of the ECO shall be identifiable in accordance with the following:

- (a) ECO members shall be identifiable by the use of coloured apparel that shall be at least one of the following:
  - (a) Helmets.
  - (b) Caps.
  - (c) Hats.
  - (d) Vests.
  - (e) Tabards.
- (b) Where in-house first aid personnel respond with the ECO, they shall be identified by a white cross on a green background
- (c) Identification apparel should be prominently marked with the wearer's ECO title (see Note 3).
- (d) The type of identification used for each ECO designation shall be consistent throughout the facility.

#### NOTES:

- 1 If there is an emergency response team included in the ECO, they should be clearly identified.
- 2 The identification colours white, yellow and red should approximate the AS 2700, RGB or CMYK colours listed in Table 5.1.
- 3 The specific floor, area or building may also be identified.

**TABLE 5.1**  
**ECO IDENTIFICATION COLOURS**

ECO position	Colour	AS 2700	RGB	CMYK
Chief warden	White	N14	255, 255, 255	0, 0, 0, 0
Deputy chief warden	White	N14	255, 255, 255	0, 0, 0, 0
Communications officer	White	N14	255, 255, 255	0, 0, 0, 0
Floor/area warden	Yellow	Y26	255, 215, 0	0, 16, 100, 0
Warden	Red	R13	227, 66, 52	0, 71, 77, 11
First aid officers	Green†	G21	14, 171, 114	62, 0, 22, 33

† White cross on a green background.

## SECTION 6 TRAINING

**6.1 GENERAL**

Training shall be conducted—

- A1 | (a) for at least one member of the EPC, to enable the EPC to competently execute its obligations;
- (b) for the ECO, in accordance with Clauses 6.3 and 6.5; and
- (c) for facility occupants, in accordance with Clauses 6.4 and 6.5.

## NOTES:

- 1 The EPC should be trained in accordance with Clause 6.2.
- 2 ECO training may be carried out over a number of sessions to impart the range of necessary skills and knowledge. This should be done as soon as is reasonably practicable, as determined by the EPC.
- 3 Training programs may be structured to embrace one or more of the classifications set out in this Section, in order to meet individual organizational needs.
- 4 A recognized competency standard should be used to develop the training.

All training and skills retention activities shall be conducted or supervised by competent person(s), as defined by Clause 1.4.5. Training shall include information on the subject of occupants and visitors with a disability.

**6.2 EPC TRAINING**

Training provided to EPC members to enable them to competently execute their obligations in accordance with Clause 6.1a should address, but not necessarily be limited to, the following:

- (a) Developing, managing and maintaining an emergency plan.
- (b) The duties of the EPC and ECO as described in the emergency response procedures and emergency plan.
- (c) The duties of the ERT, where it exists, as described in the emergency response procedures and emergency plan.
- (d) The conduct of site-specific emergency identification and analysis.
- (e) Establishing and managing an ECO (see Clause 2.2).
- (f) The management of appropriate documentation.
- (g) The management and development of assessment activities.
- (h) The development and implementation of training activities including emergency exercise management.
- (i) Emergency mitigation, emergency preparedness and emergency prevention.
- (j) The installed fire safety systems, for example, sprinkler systems, fire doors and installed emergency communications, notifications and warnings.
- (k) Liaison with Emergency Services.
- (l) Post-evacuation management.

### 6.3 ECO TRAINING

#### 6.3.1 All ECO members

##### 6.3.1.1 General

All ECO members, including nominated deputies, shall be trained to develop the skills and knowledge necessary to undertake the duties set out in the emergency response procedures.

There shall be sufficient personnel trained in all positions within the ECO to allow for projected absences.

NOTE: Re-training should be conducted following a revision of the emergency response procedures.

##### 6.3.1.2 Content

The training shall address, but not necessarily be limited to, the following:

- (a) The duties of the ECO as described in the emergency response procedures and emergency plan.
- (b) Procedures for the specific emergencies contained in the emergency plan.
- (c) Responding to alarms and reports of emergencies.
- (d) Reporting emergencies and initiating the installed emergency warning equipment.
- (e) Communication during emergencies.
- (f) Pre-emergency activities
- (g) Emergency activities.
- (h) Post-emergency activities.
- (i) Occupants and visitors with disabilities.  
NOTE: This may need to include training on personal emergency evacuation plans.
- (j) Human behaviour during emergencies.
- (k) The use of installed emergency response equipment.  
NOTE: Examples include evacuation chairs, evacuation sheets and WIP phones.
- (l) The performance of the building and its installations during a fire or other emergency.  
NOTE: Examples include fire doors, emergency lights, exit-signage, sprinklers, ventilation and smoke control systems and fire-rated stairs.

The training shall include exercises and assessment.

#### 6.3.2 Chief warden, deputy chief warden, communications officer

In addition to the training for all ECO members listed in Clauses 6.3.1 and 6.3.2, persons appointed to the positions of chief warden, deputy chief warden and communications officer, along with the nominated deputies for each position, shall have additional training, including but not limited to the following:

- (a) Their roles and responsibilities within the emergency plan.
- (b) Duties of the EPC.
- (c) Duties of the ERT, where it exists, as described in the emergency response procedures.
- (d) Decision-making, command and control.
- (e) Record keeping.
- (f) Actions for the specific emergencies contained in the emergency response procedures.

- (g) Coordination of communications(s) during emergencies, including use of any installed specialised communications equipment.
- (h) Liaison with Emergency Services.
- (i) Coordination of evacuation activities.
- (j) Implementation of post-emergency activities in accordance with the emergency plan.

### 6.3.3 First-attack firefighting

Where first-attack firefighting by specific occupants is included in the emergency procedures, these occupants shall be trained to enable them to competently execute their duties.

The training for first-attack firefighting shall address, but not necessarily be limited to, the following:

- (a) The duties of the ECO, and ERT, where it exists.
- (b) Preparing for site-specific fires.
- (c) Reporting fires.
- (d) Evacuating from endangered areas.
- (e) Identifying, reporting and correcting unsafe conditions.
- (f) Responding to fire emergencies.
- (g) Identifying the classes of fire.
- (h) Selecting the correct first-attack firefighting equipment.
- (i) Safe operating procedures for first-attack firefighting equipment.
- (j) Determining if it is safe and appropriate to use first-attack firefighting equipment.
- (k) Procedures to be followed after first-attack firefighting equipment has been used.
- (l) Post evacuation activities.

NOTE: For example, extinguisher re-fill.

### 6.3.4 Emergency response skills training

Where a specialist ERT has been deemed necessary, training specific to the emergencies identified in the emergency plan shall be developed and carried out. In addition to the training detailed in Clause 6.3.3, response skills training shall address but not necessarily be limited to the following:

- (a) Command and control.
- (b) Safe, effective actions to take control of workplace emergencies.
- (c) Pre-emergency planning.
- (d) Reacting safely to emergencies.
- (e) Emergencies that may occur.
- (f) Procedures for specific emergencies.
- (g) Specialized equipment use.
- (h) Pre- and post-emergency servicing requirements
- (i) Responding to identified emergencies.

## 6.4 OCCUPANTS AND VISITORS

### 6.4.1 Occupants working at a facility

All occupants working at a facility shall receive training to enable them to act in accordance with the emergency response procedures.

The training set out in this Clause should be provided for all new occupants including casual occupants/employees, at the commencement of their duties in a workplace or their occupancy of a structure.

The training should include, but not necessarily be limited to, the following:

- (a) Occupant responsibilities within the facility emergency response procedures.
- (b) The types of emergencies contained in the emergency plan.
- (c) How to report emergencies including activation of alarm systems, if installed.
- (d) Recognising and reporting unsafe conditions, and correcting unsafe conditions when appropriate.
- (e) The authorities, roles, responsibilities and identification of ECO members.
- (f) Reacting safely to emergencies and alarms.
- (g) Evacuation procedures.
- (h) The location of internal and external staging and assembly areas, as contained in the emergency plan.
- (i) The location of egress routes.
- (j) Post-emergency protocols.
- (k) Procedures for specific emergencies.

### 6.4.2 Occupants not working at a facility

Occupants of a facility, who do not work at that facility, should receive training to enable them to act in accordance with the emergency response procedures. If training is not given, appropriate information should be provided.

### 6.4.3 Visitors

Visitors at the facility should be provided with appropriate information on the emergency response procedures, as determined by the EPC.

## 6.5 SKILLS RETENTION

### 6.5.1 ECO skills retention

#### 6.5.1.1 General

ECO members, including nominated deputies, shall attend a skills retention activity at intervals not greater than 6 months.

Skills retention activities shall—

- (a) be determined by the EPC, based on the specific requirements for the facility and its emergency plan;
- (b) include revision of roles and responsibilities as set out in the emergency response procedures; and
- (c) include instruction on the operation of the communications system (if installed).

Skills retention activities may also include, but not necessarily be limited to, table-top exercises and evacuation exercises for the ECO.

### 6.5.2 Occupant skills retention

In workplaces, occupants should participate in skills retention activities at intervals not greater than 12 months, to enable them to act in accordance with the emergency response procedures.

Occupants' skills retention activities shall address the following:

- (a) Responding to alarms and reports of emergencies.
- (b) Personal emergency evacuation plans, where these are in place.
- (c) Procedures for specific emergencies as contained in the emergency response procedures.
- (d) Identification of ECO members.

Occupant skills retention may be delivered by various methods (e.g., verbal, classroom, diagrams and online).

### 6.5.3 First-attack firefighting

Where first-attack firefighting by specific occupants is included in the emergency procedures, these occupants shall attend a skills retention activity in first-attack firefighting at intervals not greater than two years.

### 6.5.4 Emergency response

Where a specialist ERT has been deemed necessary, the ERT members shall attend a skills retention activity in their specific procedures at intervals not greater than one year.

## 6.6 COMMUNICATIONS SYSTEM

All ECO members shall be instructed on the operation of the communication system (if installed).

Regular checks of the communication system should be carried out, either at monthly intervals, or as determined by the EPC. Records shall be retained.

#### NOTES:

- 1 Communication systems include EWIS, s.s.e.p., PA systems, paging, portable occupant warning equipment, strobe lights and colour-coded lights.
- 2 The conduct of regular checks by ECO members provides the necessary practice in the effective use of the system and the timely identification of any system faults.
- 3 AS 1851 sets out step-by-step requirements and time intervals for the verification of elements and equipment relating to emergency response procedures.

### 6.7 TRAINING MATERIALS

The ECO and occupants shall be supplied with training materials appropriate to each person's role and level of responsibility as determined by the emergency plan. Training materials shall be site specific.

Materials shall be supplied in a format that can be comprehended by the recipient, which may include, but not be limited to, the following formats:

- (a) Printed.
- (b) Large print.
- (c) Electronic.
- (d) Audio.
- (e) Braille.
- (f) Languages other than English.
- (g) Single reference charts/flip charts.

When emergency colour codes are used, they shall be in accordance with Clause 4.3.

## SECTION 7 EMERGENCY RESPONSE EXERCISES

### 7.1 GENERAL

A program of site-specific emergency response exercises shall be developed in collaboration with the facility owners, managers, occupiers and employers each facility to determine the effectiveness of the emergency response procedures, ECO actions and occupants' response, both when first developed and on an ongoing basis.

A1 | The initial testing and implementation of the emergency response exercises shall be in accordance with Clause 7.2. The ongoing program of emergency response exercises shall be in accordance with Clause 7.3.

The following should apply for all emergency response exercises (see Note 1):

- (a) Emergency response exercises should be consistent with the identified emergencies in the emergency plan.
- (b) Simple objectives and outcomes for emergency response exercises should be identified (see Notes 2 and 3).
- A1 | (c) Observers should be appointed for all emergency response exercises. The observers should use a checklist to record the details of the emergency response exercise (see Notes 4 and 5).
- (d) Each emergency response exercise should be prefixed by an announcement that it is an exercise only.
- (e) Debriefing sessions should be held in accordance with Clause 7.6.
- A1 | (f) A report should be forwarded to the EPC following each emergency response exercise. The report should include any deficiencies in the evacuation exercise that were identified at the debriefing session.

#### NOTES:

- 1 Emergency response exercises should be conducted during the operating hours of the facility to appropriately test the ECO, emergency response procedures and responses of the occupants and visitors.
- 2 An example of objectives for an emergency response exercise is to gauge ECO response and to identify and correct any deficiencies in communication system(s), training, emergency response procedures, or their implementation.
- 3 The outcomes for emergency response exercises should include the following, as appropriate to the emergency response procedures:
  - (a) ECO initiates the emergency procedure without waiting for instructions.
  - (b) ECO responds to alarms.
  - (c) ECO searches their allocated area without delay.
  - (d) ECO reports the location of any occupants and visitors with a disability.
  - (e) Simulated calls made to the Emergency Service, as appropriate.
  - (f) Effective ECO communication.
  - (g) The designated location for controlling the emergency is staffed immediately by the chief warden.
  - (h) The evacuation sequence is carried out in accordance with the procedures.
- 4 An observer's role is to observe and note the action taken by ECO members and occupants during the evacuation exercise.
- 5 See Appendix G for an example of an observers' checklist.

## 7.2 INITIAL TESTING AND IMPLEMENTATION

Once the EPC has established that the emergency response procedures are satisfactory and workable and the ECO has been trained, the emergency response procedures should be tested within the first 12 months.

A1 | The first emergency response exercise should be an evacuation exercise (see Note 1).

### 'Text deleted'

The EPC in collaboration with the facility owners, managers, occupiers and employers should arrange for occupants to be notified before the evacuation exercise takes place. Adequate planning time, including the proposed date, shall be given.

All occupants and ECO members shall have participated in an evacuation exercise in the first 12 months of the implementation of the emergency response procedures.

#### NOTES:

- 1 If the facility is large or a multi storey building, a partial evacuation may be undertaken to test the emergency response procedures and the ECO in the first instance.
- A1 | 2 The initial emergency response exercise(s) may be a simulation or practical exercise to test all emergency procedures and the ECO members.
- 3 Notification may be carried out by various members of the ECO facility owners, managers, occupiers and employers thus enabling the occupants to identify their warden(s) and become aware of their responsibilities.
- 4 Realistic performance targets may be considered as a measure of the procedures' effectiveness.
- 5 The ECO should be briefed to give extra assistance to staff during the initial evacuations.
- 6 It should be accepted by management that the emergency response procedures be properly tested and that all ECO members have sufficient practice to ensure their effectiveness in an emergency situation. In less complex facilities this may only be a matter of sounding the alarm, having people walk to the assembly area and accounting for people. With the experience gained from the first evacuation, subsequent evacuation exercises will become more realistic.

## 7.3 ONGOING PROGRAM

A1 | Following the implementation phase, a program of site-specific emergency response exercises shall be developed for each facility.

The size and configuration of the facility, together with the type of occupancy, will determine the type and time interval between emergency response exercises. These may be conducted either as partial emergency response exercises or a total emergency response exercise covering the entire facility. All areas of a facility shall participate in at least one emergency response exercise involving an evacuation each year.

A1 | All occupants of the floor(s) or area(s) involved in the emergency response exercise shall take part, unless the EPC grants a written exemption prior to conducting the emergency response exercise.

#### NOTES:

- 1 The aim of emergency response exercises is to have all occupants participate in at least one emergency response exercise per year consistent with the nature of the facility and its identified emergencies.
- 2 For training purposes, exemptions may be treated by the ECO as refusals for the emergency response exercise.
- 3 Where exemptions to remain are given, the ECO should report the exempted occupants to the chief warden.

#### 7.4 ECO BRIEFING

- A1 | When planning any emergency response exercise, briefing the ECO shall be considered. The briefing may address, but not be limited to the following:
- (a) The location of the planned scenario.
  - (b) The identity of the wardens.
  - (c) The type of alarms and alarm system, (if installed).
  - (d) Actions that the ECO is to take in response to the alarm signals.
  - (e) The method of reporting emergencies.
  - (f) The location of the staging area on the occupants' floor or area if applicable.
  - (g) The evacuation routes to be taken.
  - (h) The location of assembly or designated alternative areas that provide safe refuge, internally or externally.
  - (i) Occupants who have approved exemptions prior to the exercise.
  - (j) Notification of any current temporary hazards within the facility and known systems failure relating to systems and equipment.
  - (k) What is required at the completion of the exercise.

#### 7.5 OBSERVERS' CHECKLIST

- A1 | An observers' checklist should be prepared for the specific facility where the evacuation exercises take place.

##### NOTES:

- 1 The checklist should be completed for each evacuation exercise and should provide the basis for discussion at the debriefing.
- 2 An example of a checklist is given in Appendix G.

#### 7.6 EMERGENCY RESPONSE EXERCISE DEBRIEFING SESSION

Immediately after an emergency response exercise, the ECO and other key participants shall attend a debriefing session conducted by the chief warden.

Where an evacuation exercise is conducted, the observer's checklist shall be analysed during debriefing sessions and any deficiencies shall be reported to the EPC.

The EPC shall arrange the amendment of the procedures, where necessary, and disseminate the information to all ECO members.

#### 7.7 AN EMERGENCY DURING AN EMERGENCY RESPONSE EXERCISE

A pre-determined word or phrase, for example, 'NO DUFF' shall be disseminated to all ECO members, for use when an actual emergency incident takes place during an emergency response exercise. The word or phrase shall signify that the emergency response exercise has been terminated and that the ECO are to stand by for further instruction.

NOTE: The word or phrase may be repeated in groups of three to overcome background noise and other distractions.

A1 | SECTION 8 REVIEW AND ROUTINE  
SERVICING

**8.1 EMERGENCY PLAN**

A1 | The EPC shall ensure that the emergency plan and associated elements developed to meet the requirements of this Standard are inspected, tested and routinely serviced.

NOTE: AS 1851 provides guidance on carrying out the emergency plan and the associated elements and inspection, testing and routine servicing activities.

Checking and testing of the emergency plan elements are categorized in AS 1851 into the following two categories:

- (a) Critical emergency evacuation system elements.
- (b) Other emergency evacuation system elements and procedures.

A1 | Any deficiency in the emergency plan or associated elements shall be reported to management or the EPC at the completion of the inspection or testing and shall be rectified with the minimum of delay.

Records shall be kept of all inspection, testing and routine servicing activities.

**'Note deleted'**

**8.2 COMMUNICATION SYSTEM**

Regular checks of the communication system shall be carried out, either at monthly intervals, or as determined by the EPC. Records shall be retained.

NOTES:

- 1 Communication systems include s.s.e.p. (EWIS, PA systems, paging, portable occupant warning equipment), strobe lights and colour coded lights.
- 2 The conduct of regular checks by ECO members provides the necessary practice in the effective use of the system and the timely identification of any system faults.

APPENDIX A  
FIRE AND SMOKE EMERGENCIES  
(Informative)

**A1 GENERAL**

This Appendix provides basic guidance on planning and response for fire and smoke emergencies. The information contained in this appendix is not sufficient, in itself, to adequately plan for a fire/smoke emergency in a facility.

**A2 ESSENTIAL STEPS**

Fire response within facility-specific emergency response should embrace the following four essential steps, which in most cases will need to be initiated concurrently:

- (a) *Life safety* Ensuring the immediate safety of anyone within the facility in a fire situation takes precedence over commercial operations and property/asset protection.
- (b) *Call the fire brigade* Calling the fire brigade in all incidents of fire or suspicion of fire (e.g., smell of smoke) as per facility emergency response procedures. There should be no criticism of any person who uses initiative in this respect nor should such action need another person's permission.

It is very important that where the fire brigade has been called by automatic means or by activating a manual call point, this is followed by a telephone call to confirm receipt of alarm and provide further information; for example, confirmation of the fire and its location.

- (c) *Evacuation* The emergency response procedures should have specific detail of emergency evacuation actions in a fire situation:
  - (i) *Effective warning arrangement* A suitable arrangement to advise occupants and visitors of a fire emergency should be available and outlined in the emergency response procedures.
  - (ii) *Assessment of all evacuation routes* Egress routes should be assessed for safety during the emergency. The effects of smoke in a fire situation may require alternative egress routes. It is important that these assessments include the requirements of occupants and visitors with a disability.
- (d) *Fight the fire* Many facilities have fire hose reels or portable fire extinguishers. Where these are installed, information should be provided to cover their selection, use and operation, (see also Section 6 for training requirements); however, immediately it becomes obvious that there are unacceptably high risks associated with attempts to control a fire, occupants should withdraw, closing but not locking doors behind them.
- (e) In facilities where layflat hoses are installed, occupants are not to attempt to use them unless specialized training has been provided; for example, to members of designated facility emergency response teams.

APPENDIX B  
BOMB THREAT  
(Informative)

### B1 GENERAL

The information in this Appendix is provided by the Australian Bomb Data Centre (ABDC). This Appendix provides basic guidance on planning and response in case of a bomb threat. The information contained in this Appendix is not sufficient, in itself, to adequately plan for a bomb threat.

Bomb threats are a serious public concern of recent times. A bomb threat could be either a prank or a genuine warning of an impending bomb attack. The uncertainty creates a risk that cannot be ignored. Usually, bomb threats are committed by individuals seeking to create a state of alarm and confusion in an organization. The disruption may be minimized by proper site-specific planning and nomination of appropriate decision-making authorities.

### B2 THREATS

Bomb threats may be in one of the following forms:

- (a) *Written threat* If a bomb threat is received in writing, it should be kept, including any envelope or container. Once a message is recognized as a bomb threat, further unnecessary handling should be avoided. Every possible effort has to be made to retain evidence such as possible fingerprints, handwriting or typewriting, paper and postmarks. Such evidence should be protected by placing the evidence in an envelope (preferably a plastic envelope).
- (b) *Telephone threat* An accurate analysis of the telephone threat can provide valuable information on which to base recommendations, action and subsequent investigation. The person receiving the bomb threat by telephone should, as soon as possible, complete the information required by a bomb threat checklist. A bomb threat checklist should be held by telephonists and other persons who regularly accept incoming telephone calls.  
NOTE: An example of a phone threat and bomb threat checklist is given in Appendix H.
- (c) *Suspect object* A suspect object is any object found on the premises and deemed a possible threat by virtue of its characteristics, location and circumstances.

### B3 EVALUATION

#### B3.1 General

Following an analysis of information received, the chief warden, or in his/her absence, the deputy chief warden should categorize the bomb threats, which may be either specific or non-specific as follows:

- (a) *Specific threat* The caller will provide more detailed information, which could include statements describing the device, why it was placed, its location, the time of activation and other details. Although less common, the specific threat is the more credible.
- (b) *Non-specific threats* An individual may make a simple statement to the effect that a device has been placed. Generally very little, if any, additional detail is conveyed before the caller terminates the conversation.

The non-specific threat is the more common, but neither threat can be immediately discredited without investigation. In other words, every threat has to be treated as genuine until proven otherwise.

### **B3.2 Actions**

The following four options are a guide to action following the evaluation of the threat:

- (a) Take no further action.
- or*
- (b) Search without evacuation. (If an item is identified as suspect during the search then evacuation should be considered).
- or*
- A2 | (c) Search followed by an evacuation. (If an item matches the description of the threat language or is deemed suspicious then an evacuation should be ordered).
- or*
- (d) Evacuate (without search).

Each of these options will have advantages and disadvantages related to safety, speed of search, thoroughness, productivity and morale, and has to be assessed against the potential risk.

## **B4 NOTIFICATION**

Upon receipt of a threat or discovery of a suspect object, the Police should immediately be advised; however, it should not be assumed that the Police will conduct bomb searches. An advantage to having developed a bomb incident plan is that coordination with public safety organizations will have been arranged with a clear understanding of exactly what services can be provided, by whom and when.

An analysis of a threat or the discovery of a suspect object should determine the requirements to evacuate the building, structure or workplace. In any circumstance where an occupier determines that an evacuation of their area is necessary, the affected occupier should first notify the ECO so that the emergency plan can be implemented.

## **B5 SEARCH**

### **B5.1 General**

The most appropriate personnel to carry out a search, in any given area, are the occupants of the building, structure or workplace because they have the knowledge of ‘what belongs’ or ‘what does not belong’ in a location at any given time.

The aim of the search is to identify any object that is not normally found in an area or location, or for which an owner is not readily identifiable or becomes suspect for any other reason, for example—

- (a) a suspiciously labelled object;
- (b) an object similar to that described in the threat;
- (c) an object of unusual size, shape and sound; or
- (d) the presence of pieces of tape, wire, string or explosive wrappings, or other unfamiliar materials.

On locating a suspect object, search personnel should not touch, cover or move it.

The location should be conspicuously marked, for example, a paper trail to the nearest exit is most suitable. After ensuring there are no other suspect objects in the vicinity, the area

should be evacuated and isolated. Search of other areas should continue to ensure that there are no other suspect objects.

NOTES:

- 1 Law enforcement authorities, i.e., the police, do not normally assist occupants of buildings, structures or workplaces in searching for suspect bombs unless a suspect bomb has been located by the site occupants.
- 2 Care should be exercised with mobile phones, radio sets, wireless technology transmission and any other equipment producing electromagnetic radiation in situations where improvised explosive devices are suspected. Such equipment should not be used until clearance is given by the attending bomb technicians.

### B5.2 Search sequence

General priorities for searching should follow the following sequence:

- (a) Outside areas including evacuation assembly areas.
- (b) Building entrances and exits and, particularly, paths people will use to evacuate.
- (c) Public areas within buildings.

NOTE: Most buildings contain public areas that are accessible for the placement of an 'object'. These areas usually provide a means of exit, which evacuees have to pass through, or be in proximity to, during an evacuation.

- (d) Other areas.

NOTE: Once external and public areas have been declared clear, a search should be conducted beginning at the lowest levels and continuing upwards until every floor, including the roof, has been searched. Once a floor or room has been searched, it should be distinctively marked to avoid duplication of effort. The ECO members, due to their intimate knowledge of the building, should assist the relevant authorities in these procedures.

## B6 EVACUATION OPTIONS

### B6.1 General

If the decision to evacuate is made, people should be requested to remove all personal belongings, e.g. handbags, briefcases, shopping or carry bags, when evacuating. This will facilitate the identification of suspect objects.

### B6.2 Limitations of total evacuation

At first thought, immediate and total evacuation would seem to be the most appropriate response to any bomb threat. However, the evacuation procedures in response to a bomb threat do not necessarily follow those for a fire, for example, doors and windows should be opened, to lessen blast effect, and not closed as in the case of fire. Additionally, there are significant safety and economic factors associated with a bomb threat, which may weigh against an immediate evacuation, as follows:

- (a) *Risk of injury* As a general rule, the easiest area in which to plant an object is in the shrubbery sometimes found outside a building, an adjoining car park or in an area to which the public has the easiest access. Immediate evacuation through these areas might increase the risk of injury and car parks should not normally be used as assembly areas.
- (b) *Response limitation* Total and prompt evacuation will remove personnel who may be required to make a search.
- (c) *Panic* A sudden bomb threat evacuation may cause panic and unpredictable behaviour, leading to unnecessary risk of injury.
- (d) *Essential services* Some evacuations may be precluded by the essential nature of the operations conducted within the building.

- (e) *Loss to business services* While the protection of life should outweigh any economic loss, repeated threats may increase loss of business and interruption of services to an unacceptable level.

There are some conditions that make immediate total evacuation an undesirable response to the bomb threat. Total and immediate evacuation, whilst risky, is the easy decision, and having taken the easy way, the hard decision of when to return still has to be made.

### **B6.3 Partial evacuation**

One alternative to total evacuation is a partial evacuation. This response is particularly effective when the threat includes the specific or general location of the placed object or in those instances where a suspect object has been located without prior warning.

Partial evacuation may reduce risk of injury by removing non-essential personnel. Personnel essential to a search may remain, critical services may be continued and, in cases of repeated threat, loss of output will be minimized. Partial evacuation requires a high degree of planning, training, supervision, coordination and rehearsal.

Suspect mail items have many similarities in common with other ‘suspect articles’, which may be encountered by any enterprise or individual. The philosophy of handling these items varies and is outside the scope of this document, but in the context of this Standard the procedures are the same.

## **B7 SUSPECT ITEMS**

### **B7.1 Identifying an item as suspect**

Suspect items may be encountered by any enterprise or individual. It is not possible to provide a definitive list of indicators that would cause an item to be considered suspect. The following questions provide a means of assessing if an item should be considered suspect:

- (a) Is the item unidentified?
- (b) Is the item unusual or foreign to its environment? Is the item typical for its environment?
- (c) Is the item obviously a bomb?
- (d) Is the item hidden or concealed in any way?
- (e) Has there been any unauthorized access to the area?
- (f) Has there been a perimeter breach?

This series of questions may be remembered using the mnemonic, ‘HOT-UP’ as shown in Figure B1.



FIGURE B1 ‘HOT-UP’

**B7.2 Actions to be taken**

The following actions should be considered for dealing with a suspect item:

- (a) The supervisor is to be informed.
- (b) Cordon-off immediate area.
- (c) Advise ECO/Security who will assess the need to alert Emergency Services.
- (d) Respond to the directions of Emergency Services if they are contacted.

A suspect item should not be moved or touched.

**B8 SUSPECT MAIL ARTICLES**

Suspect mail items have many similarities in common with other 'suspect articles', which may be encountered by any enterprise or individual. The philosophy of handling these items varies and is outside the scope of this document.

All occupants responsible for handling mail should be trained in the identification and subsequent handling of suspect mail items. Where large quantities of mail are received, or where the organization is considered at high risk, then consideration for the installation of specialized equipment has to be a management priority. Where necessary, further information can be obtained through the ABDC.

NOTE: The ABDC has produced a handbook for managers, which provides detailed guidelines for planning for bomb threats and identifying/handling suspect mail items titled, *Bombs Defusing the Threat, Incorporating Mail Bomb Countermeasures*. Organizations may obtain the publication by writing to the Australian Bomb Data Centre, Australian Federal Police Headquarters, Canberra.

**B9 TYPES OF BOMB DELIVERY**

Types of bomb delivery include the following:

- (a) *Courier-delivered bomb* An explosive device delivered by a courier.
- (b) *Improvised explosive device (IED)* A device fabricated in an ad hoc manner which contains explosive components designed to, or capable of, causing unlawful injury or damage.
- (c) *Mail bomb* An IED sent through the postal system
- (d) *Placed bomb* An explosive device hand-delivered or purposefully placed.
- (e) *Vehicle bomb* A bomb in which a vehicle is used as the means of delivery. It may be designed to use the vehicle as fragmentation.

APPENDIX C  
CIVIL DISORDER AND ILLEGAL OCCUPANCY  
(Informative)

**C1 GENERAL**

This Appendix provides basic guidance on planning and response for civil disorder and illegal occupancy. The information contained in this Appendix is not sufficient, in itself, to adequately plan for civil disorder and illegal occupancy.

Planning for these emergencies may be done in consultation with the police or other specialist advisers and should be specific to the facility. This planning should be consistent with the facility's security standard operating procedure.

There have been many examples where industrial unrest, an emotional international situation or an unpopular political decision, have led to public demonstrations.

Planning for emergencies should include the development of procedures and guidelines aimed at minimizing the danger to facility occupants and visitors, and may include the risks of asset and revenue loss.

The ECO, together with managers and supervisors may be responsible for co-ordinating the response to such incidents, until the arrival of police to whom they should provide such assistance as may be required.

Managers and supervisors can contribute in a practical way to the satisfactory resolution of these emergencies by ensuring withdrawal of their staff where necessary, supervising the locking up of offices, securing records, files, cash and other valuable property while at the same time promoting an air of confidence and calm.

**C2 RESPONSE**

Immediately the chief warden is aware of civil disorder occurring in, or in the vicinity of, the facility, the imminence of such an event, or an unauthorized entry into the facility by a disaffected person or group, the chief warden or any senior member of the ECO who is in a position to act, should take the following action:

- (a) Notify the police and request assistance.
- (b) Alert members of the ECO.
- (c) Inform facility occupants and visitors of restrictions to be implemented.
- (d) Initiate the following actions:
  - (i) *For illegal occupants—*
    - (A) restrict illegal occupants to affected area;
    - (B) restrict facility occupants' and visitors' access to affected area;
    - (C) inform occupants and visitors of unaffected areas to remain at their location unless otherwise advised; and
    - (D) implement specific facility security protocols.

- (ii) *For civil disorder—*
- (A) restrict access to and egress from the facility;
  - (B) inform occupants and visitors of unaffected areas to remain at their location unless otherwise advised;
  - (C) restrict contact between the demonstrators and the facility occupants;
  - (D) implement specific facility security protocols;
  - (E) restrict the use of external non-emergency communication; and
  - (F) notify managers and supervisors.

APPENDIX D  
EXAMPLE OF A PERSONAL EMERGENCY EVACUATION PLAN (PEEP)  
(Informative)

**PERSONAL EMERGENCY EVACUATION PLAN**

Occupant's Name: .....

Location:

Building/Facility .....

Floor .....

Room Number .....

Is an Assistance Animal involved? Yes  No

Are you trained in the emergency response procedures (including the evacuation procedures)? Yes  No

Preferred method of receiving updates to the emergency response procedures:  
*(Please state, e.g. text, email, Braille etc.)*  
.....

Preferred method for Notification of Emergency:  
*(Please state, e.g. visual alarm, personal vibrating device, SMS, etc. Add lines as necessary)*  
.....

Type of assistance required:  
*(Please list procedures necessary for assistance. Add lines as necessary)*  
.....  
.....  
.....

Equipment required for evacuation:  
*(Please list. Add lines as necessary)*  
.....  
.....  
.....

Accessed by UNIVERSITY OF NEWCASTLE on 14 Oct 2019 (Document currency not guaranteed when printed)

Egress procedure:

(Give step by step details. Add lines as necessary)

- 1. ....
- 2. ....
- 3. ....
- 4. ....

Designated assistants and contact details:

(Please list name, phone, mobile, email. Add lines as necessary)

.....

.....

.....

Are your designated assistants trained in the emergency response procedures (including the evacuation procedures)?

Yes  No

Are your designated assistants trained in the evacuation equipment?

Yes  No

Diagram of preferred route for assisted evacuation:

(Please provide diagram)

Issue Date: .... / .... / .....

Review Date: .... / .... / .....

Occupant approved:

Date: .... / .... / .....

.....  
(signature)

Chief Warden:

Date: .... / .... / .....

.....  
(signature)

Accessed by UNIVERSITY OF NEWCASTLE on 14 Oct 2019 (Document currency not guaranteed when printed)

APPENDIX E  
EXAMPLE EVACUATION DIAGRAMS  
(Informative)

- Figure E1 gives an example of an evacuation diagram complying with Clause 3.5.5.  
Figure E2 gives an example of an evacuation diagram complying with Clause 3.5.6.  
A1 | Neither figure is shown to scale. Figure E3 gives an example of symbols used in evacuation diagrams.

A1

Accessed by UNIVERSITY OF NEWCASTLE on 14 Oct 2019 (Document currency not guaranteed when printed)

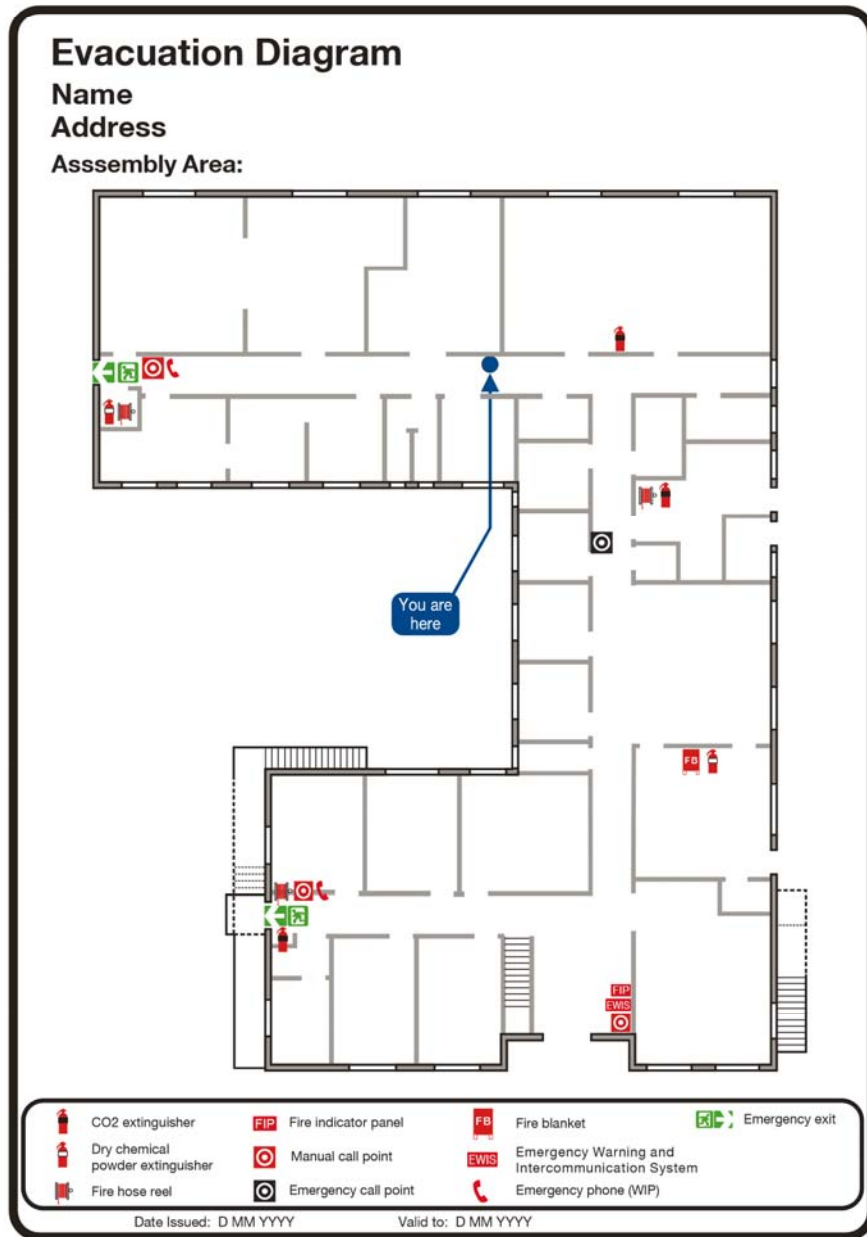

NOT TO SCALE

**NOTES:**

- 1 Refer to Clause 3.5.5 for the list of minimum elements to be included on an evacuation diagram.
- 2 A refuge is not depicted in this diagram. Refuges are included if they are present at the facility.

**FIGURE E1 EXAMPLE OF AN EVACUATION DIAGRAM DISPLAYING MINIMUM ELEMENTS—A4 MINIMUM SIZE**

Accessed by UNIVERSITY OF NEWCASTLE on 14 Oct 2019 (Document currency not guaranteed when printed)

A1

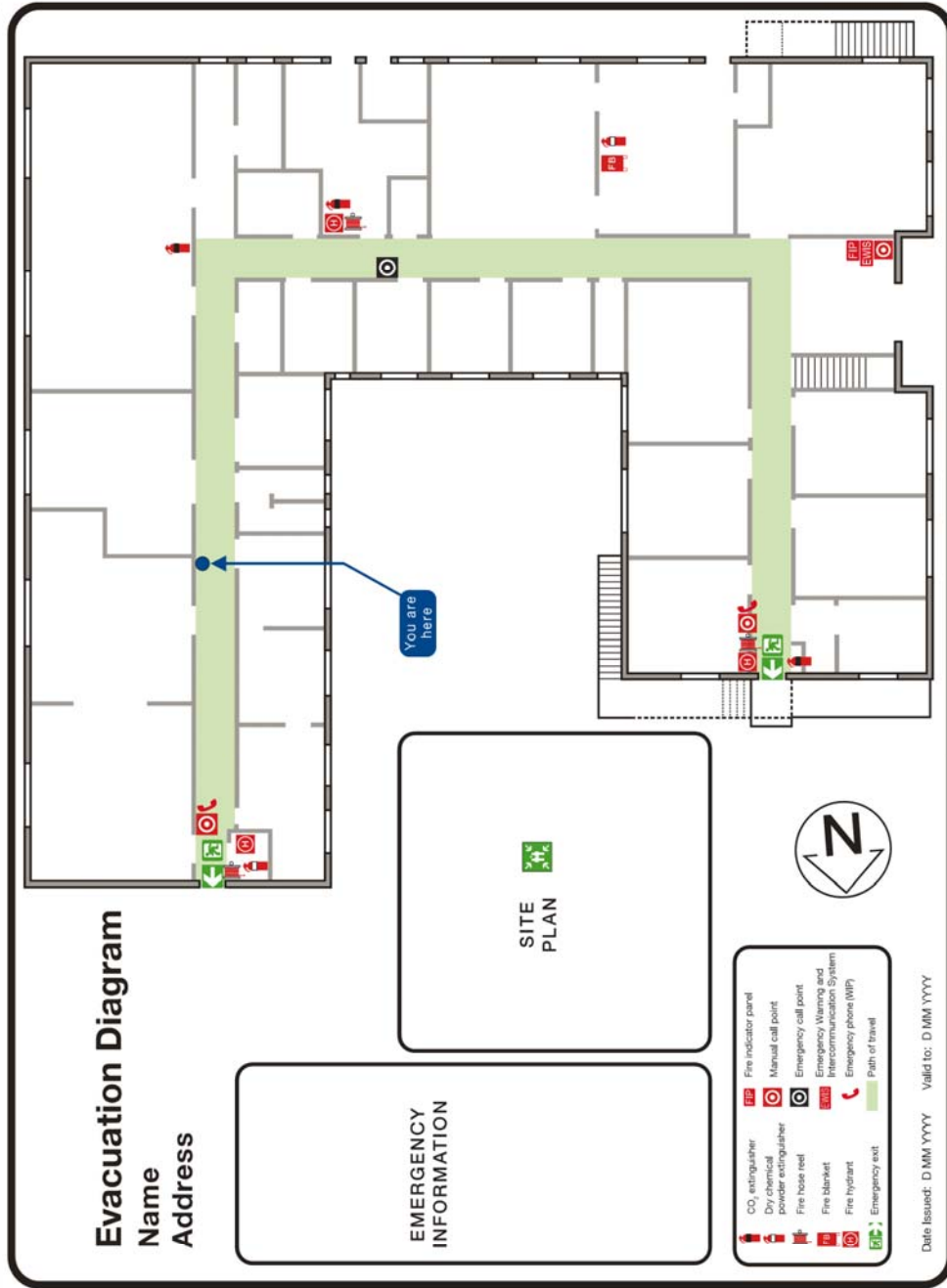

NOTE: Refer to Clause 3.5.6 for the list of optional elements that may be included on the evacuation diagram.

FIGURE E2 EXAMPLE OF AN EVACUATION DIAGRAM DISPLAYING MINIMUM AND OPTIONAL ELEMENTS—A3 MINIMUM SIZE



FIGURE E3 EXAMPLES OF SYMBOLS USED IN EVACUATION DIAGRAMS

APPENDIX F  
GUIDANCE ON DETERMINING ECO NUMBERS  
(Informative)

**F1 GENERAL**

A sufficient number of ECO members need to be appointed to ensure that whenever the facility is occupied, ECO members are available to respond to a facility emergency and to enable the facility to be checked and evacuated quickly and efficiently without compromising any occupants' and visitors' safety.

The number of ECO members required for a facility will vary depending upon the facility's structural and occupant/visitor characteristics. Characteristics that may impact on the number of ECO members are listed in Paragraphs F2 and F3. In addition, life safety and management and use provisions need to be considered such as—

- (a) fire safety audits;
- (b) risk assessments;
- (c) fire safety engineering reports;
- (d) fire safety plans;
- (e) method of warning occupants and visitors;
- (f) evacuation strategy (staged, horizontal, etc.);
- (g) use of evacuation routes; and
- (h) use of lifts.

Once all of the necessary information has been collected, an analysis of the needs relating to occupant and visitor evacuation should be made to assist in determining the appropriate number of ECO members to be selected.

The analysis may be based on data from the literature, field studies or simulated evacuations and engineering judgement. In some cases the regulatory approval process may have required a fire engineering report or the analysis of occupant and visitor evacuation and this could be used for this process.

**F2 FACILITY STRUCTURAL CHARACTERISTICS**

The following facility structural characteristics should be taken into account when determining ECO numbers:

- (a) *Occupancy* Including—
  - (i) building classification; and
  - (ii) facility usage, particularly unusual uses.
- (b) *Location* Including—
  - (i) proximity to other buildings and boundaries; and
  - (ii) proximity to other hazards.
- (c) *Size and shape* Including—
  - (i) number and size of floors/zones/areas;
  - (ii) layout; and
  - (iii) egress.

- (d) *Structure* Including—
  - (i) construction materials;
  - (ii) openings, shafts and ducts; and
  - (iii) ventilation and air movement.
- (e) Unusual features.
- (f) Hazards to occupants and visitors.
- (g) Fire safety measures.
- (h) Management and use.
- (i) Training of occupants.
- (j) Maintenance frequency and adequacy of maintenance regimes.
- (k) Firefighting concerns.

### **F3 OCCUPANT AND VISITOR CHARACTERISTICS**

Occupant and visitor characteristics that should be considered include the following:

- (a) Number, gender, age, location and state, e.g. awake or asleep, intoxicated or sober, unconscious or fully conscious.
- (b) Physical attributes, e.g. mobility, speed of travel.
- (c) Hearing ability.
- (d) Vision ability.
- (e) Mental attributes.
- (f) Level of understanding.
- (g) Potential emergency behaviour.
- (h) Ability to interpret cues.
- (i) Ability to take and implement decisions independently.
- (j) Level of assistance required, e.g. requires full assistance, requires some assistance or does not require assistance.
- (k) Level of assistance available.
- (l) Shift schedules.
- (m) Staff, occupant and visitor numbers and type at any time in facility.
- (n) Emergency training, for example trained or untrained.
- (o) Occupant (group) roles, e.g. parent or child, teacher or student, nurse or patient, staff or customer.
- (p) Activity at the outbreak of fire, e.g. asleep or awake.
- (q) Working in a noisy environment.
- (r) Watching a performance.
- (s) Familiarity with the building, i.e. unfamiliar, relatively familiar or familiar.

APPENDIX G  
 EXAMPLE OF AN EMERGENCY EVACUATION EXERCISE  
 OBSERVERS' CHECKLIST  
 (Informative)

DATE: .....

ADDRESS: .....

FLOOR OR AREA: .....

EVACUATION SEQUENCE	TIME	
	HOURS	MINUTES
Alarm sounded	.....	.....
Warden(s) respond	.....	.....
Wardens check floor or area	.....	.....
Evacuation commenced	.....	.....
Wardens report floor or area clear	.....	.....
Persons with disabilities accounted for	.....	.....
Arrive at assembly area, safe place	.....	.....
Wardens check personnel present (where appropriate)	.....	.....
Evacuation completed	.....	.....
Exercise terminated	.....	.....

COMMENTS:

.....

.....

.....

.....

.....

.....

OBSERVER: .....

(CAPITALS)

SIGNED: .....

Accessed by UNIVERSITY OF NEWCASTLE on 14 Oct 2019 (Document currency not guaranteed when printed)

APPENDIX H  
EXAMPLE OF A PHONE THREAT CHECKLIST  
(Informative)

This Appendix provides an example of a typical phone threat and bomb threat checklist (see next page). It is reproduced from the Australian Bomb Data Centre Bomb Safety Awareness Kit, with the permission of the Australian Bomb Data centre.

**PHONE THREAT CHECK LIST<sup>®</sup>**  
**KEEP CALM**  
**RECIPIENT**

Name (print): Telephone number: Signature:
--

**GENERAL QUESTIONS TO ASK:**

- |  |
|--|
| <ol style="list-style-type: none"> <li>1. What is it ?</li> <li>2. When is the bomb going to explode ?<br/>               OR<br/>               When will the substance be released ?</li> <li>3. Where did you put it ?</li> <li>4. What does it look like ?</li> <li>5. When did you put it there ?</li> <li>6. How will the bomb explode ?<br/>               OR<br/>               How will the substance be released ?</li> <li>7. Did you put it there ?</li> <li>8. Why did you put it there ?</li> </ol> |
|--|

**CHEMICAL / BIOLOGICAL THREAT QUESTIONS**

- |   |
|---|
| <ol style="list-style-type: none"> <li>1. What kind of substance is in it ?</li> <li>2. How much of the substance is there ?</li> <li>3. How will the substance be released ?</li> <li>4. Is the substance a liquid, powder or gas ?</li> </ol> |
|---|

**BOMB THREAT QUESTIONS**

- |  |
|--|
| <ol style="list-style-type: none"> <li>1. What type of bomb is it ?</li> <li>2. What is in the bomb ?</li> <li>3. What will make the bomb explode ?</li> </ol> |
|--|

**EXACT WORDING OF THREAT:**

--

**CALLER'S VOICE**

Accent (specify): Any impediment (specify): Voice (loud, soft, etc): Speech (fast, slow, etc): Diction (clear, muffled): Manner (calm, emotional, etc): Did you recognise the caller ? If so who do you think it is ? Was caller familiar with the area ?
---

**THREAT LANGUAGE**

Well spoken: Incoherent: Irrational: Taped: Message read by caller: Abusive: Other:
---

**BACKGROUND NOISES**

Street noises: House noises: Aircraft: Voices: Music: Machinery: Other: Local Call: STD Call:
---

**NOTES:**

--

**OTHER**

Sex of caller:	Estimated age:
----------------	----------------

**CALL TAKEN:**

Date:   Time: Duration of call: Number called:
--

**ACTION (OBTAIN DETAILS FROM SUPERVISOR)**

Report call immediately to: Phone number:
--

AUSTRALIAN BOMB DATA CENTRE  
 GPO Box 401 CANBERRA ACT 2601  
 Telephone: 02 6287 0750 Facsimile: 02 6287 0770

## BIBLIOGRAPHY

- AS  
1851 Maintenance of fire protection systems and equipment  
4083 Planning for emergencies—Health care facilities

**AMENDMENT CONTROL SHEET**

**AS 3745—2010**

---

**Amendment No. 1 (2014)**

---

**REVISED TEXT**

*SUMMARY:* This Amendment applies to the Preface, Foreword, Clauses 1.3, 1.4.10A (new), 3.1, 3.4, 3.5.1, 3.5.5, 3.5.6, 3.5.7, 3.6, 3.7, 4.1, 4.2.1, 4.2.6.3, 4.2.9, 4.2.11, 5.7.3, 6.1, 6.4.2, 7.1, 7.2, 7.3, 7.4, 7.5, Section 8, Clause 8.1, Appendix E, and Figures 3.1, 3.2, E1, E2 and E3.

Published on 1 May 2014.

---

**Amendment No. 2 (2018)**

---

**REVISED TEXT**

*SUMMARY:* This Amendment applies to the Preface, Clauses 1.4.14A, 1.4.20A, 1.4.20B, 3.5.1, 3.5.2, 3.5.3, 3.5.5, 3.5.6, 4.2.5, 4.2.6.3, 5.7.2, 6.3.3, Appendix B, and Figure 3.1.

Published on 29 June 2018.

---

### **Standards Australia**

Standards Australia develops Australian Standards® and other documents of public benefit and national interest. These Standards are developed through an open process of consultation and consensus, in which all interested parties are invited to participate. Through a Memorandum of Understanding with the Commonwealth Government, Standards Australia is recognized as Australia's peak non-government national standards body. Standards Australia also supports excellence in design and innovation through the Australian Design Awards.

For further information visit [www.standards.org.au](http://www.standards.org.au)

### **Australian Standards®**

Committees of experts from industry, governments, consumers and other relevant sectors prepare Australian Standards. The requirements or recommendations contained in published Standards are a consensus of the views of representative interests and also take account of comments received from other sources. They reflect the latest scientific and industry experience. Australian Standards are kept under continuous review after publication and are updated regularly to take account of changing technology.

### **International Involvement**

Standards Australia is responsible for ensuring the Australian viewpoint is considered in the formulation of International Standards and that the latest international experience is incorporated in national Standards. This role is vital in assisting local industry to compete in international markets. Standards Australia represents Australia at both the International Organization for Standardization (ISO) and the International Electrotechnical Commission (IEC).

### **Sales and Distribution**

Australian Standards®, Handbooks and other documents developed by Standards Australia are printed and distributed under licence by SAI Global Limited.

*For information regarding the development of Standards contact:*

Standards Australia Limited  
GPO Box 476  
Sydney NSW 2001  
Phone: 02 9237 6000  
Email: [mail@standards.org.au](mailto:mail@standards.org.au)  
Internet: [www.standards.org.au](http://www.standards.org.au)

*For information regarding the sale and distribution of Standards contact:*

SAI Global Limited  
Phone: 13 12 42  
Email: [sales@saiglobal.com](mailto:sales@saiglobal.com)



ISBN 978 0 7337 9727 9

This page has been left intentionally blank.

---

**15.4 CONSULTATION WITH NSW RURAL FIRE SERVICE**

---

Document Title:	<b>Bushfire Management Plan – Rix's Creek Mine</b>		Document Owner:	<b>Chris Knight</b>	
Prepared By:	Chris Quinn	Print Date:	1-Apr-26	Version No:	1.3
Reviewed By:	Julius Harris-Payne	Review Frequency:	<b>As Required</b>	Issue Date:	1/04/2026
Approved By:	Brendon Clements			Page No:	35 of 35

## Chris Knight

---

**From:** Chris Knight  
**Sent:** Monday, 13 January 2020 10:35 AM  
**To:** 'hunintervalley.team@rfs.nsw.gov.au'  
**Subject:** Bushfire Management Plan- Rix's Creek Mine

Hi Paul,  
I hope the New Year finds you well.

Thank you and your team for all of your fantastic work saving the many lives and properties over the last few months. I realise that you will have been far too busy to look at the Rix's Creek Bushfire Management Plan.

This email is just to check in so the Plan does not fall off my list. I look forward to hearing from you whenever you get a chance.

Thank you and your teams again for all your efforts with the recent bushfires.

Best Regards



**Chris Knight**

Environment Manager

E: [cknight@bloomcoll.com.au](mailto:cknight@bloomcoll.com.au) | T: 02 6578 8824 | M: 0403 058 777

W: [www.bloomcoll.com.au](http://www.bloomcoll.com.au)

PO Box 4, East Maitland, NSW 2323

**WE CARE. WE DELIVER.**

North: Bridgman Road, South: Rixs Creek Lane, Singleton, NSW 2330 Australia

Please note: If you have received this e-mail in error, please notify the sender immediately by reply e-mail and delete all copies of this transmission together with any attachments as the information contained and any attached files may be confidential and/or subject of legal professional privilege.

---

**From:** Chris Knight  
**Sent:** Wednesday, 30 October 2019 12:21 PM  
**To:** 'hunintervalley.team@rfs.nsw.gov.au' <hunintervalley.team@rfs.nsw.gov.au>  
**Cc:** Chris Quinn <cquinn@bloomcoll.com.au>; Geoff Moore <gmoore@bloomcoll.com.au>; Hannah Lumsden <hlumsden@bloomcoll.com.au>  
**Subject:** Bushfire Management Plan- Rix's Creek Mine

**Attn: Paul Best, Team Manager, Hunter Valley Team.**

Dear Paul,

The Rix's Creek South Continuation Project was recently approved for a further 21 years. As part of this approval Rix's Creek Mine are required to prepare a Bushfire Management Plan for the development in consultation with RFS. In accordance with this condition, please find attached the Rix's Creek Mine Bushfire Management Plan for your review and comment.

If you have any questions or require any further information please do not hesitate to contact this office.

Best Regards,



**WE CARE. WE DELIVER.**

**Chris Knight**

Environment Manager

E: [cknight@bloomcoll.com.au](mailto:cknight@bloomcoll.com.au) | T: 02 6578 8824 | M: 0403 058 777

W: [www.bloomcoll.com.au](http://www.bloomcoll.com.au)

PO Box 4, East Maitland, NSW 2323

North: Bridgman Road, South: Rixs Creek Lane, Singleton, NSW 2330 Australia

Please note: If you have received this e-mail in error, please notify the sender immediately by reply e-mail and delete all copies of this transmission together with any attachments as the information contained and any attached files may be confidential and/or subject of legal professional privilege.

## Chris Knight

---

**From:** Leanne Bell <Leanne.Bell@rfs.nsw.gov.au>  
**Sent:** Monday, 13 January 2020 11:44 AM  
**To:** Chris Knight  
**Cc:** Paul Best  
**Subject:** FW: Bushfire Management Plan- Rix's Creek Mine  
**Attachments:** Fact Sheet - Mining Industry - Bush Fire Management Plans.pdf

Hi Chris,

Thanks for a copy of your plan and map for your Bush Fire Management Plan. I have been on deployment since early October and have not seen my desk for some time. I'm not going to have the time to provide feedback on your plan in the near future. It would be beneficial to both organisations that in future, Bush Fire Management Plans are submitted prior to the 1<sup>st</sup> September, the beginning of Fire Season.

Attached is a fact sheet for the Mining Industry on Bush Fire Management Plans, please review and ensure that the correct details are included in your plan. The most common error in the plans are:

- Bush Fire Danger Period – for the Hunter Valley area (Singleton & Muswellbrook LGA's) this is 1<sup>st</sup> September to 31 March
- Bush Fire Management Committee name – Hunter Valley Bush Fire Management Committee
- Fire weather area – Greater Hunter
- NSW RFS district – Hunter Valley District
- Contact Phone number business hours – 6575 1200

If you make changes to your plan as a result of this fact sheet, please record them in the consultation section of your plan and then re-send to me for our records.

Thanks and regards  
Leanne



**Leanne Bell** | Operational Officer | Hunter Valley  
**NSW RURAL FIRE SERVICE**  
2161 Putty Road Bulga NSW 2330 | PO Box 3111 Singleton NSW 2330  
**P** 02 6575 1200 **F** 02 6575 1299 **M** 0428 343 402 **E** [Leanne.Bell@rfs.nsw.gov.au](mailto:Leanne.Bell@rfs.nsw.gov.au)  
[www.rfs.nsw.gov.au](http://www.rfs.nsw.gov.au) | [www.facebook.com/nswrfs](https://www.facebook.com/nswrfs) | [www.twitter.com/nswrfs](https://www.twitter.com/nswrfs)  
**PREPARE. ACT. SURVIVE.**

---

**From:** Hunter Valley Team <HunterValleyTeam@rfs.nsw.gov.au>  
**Sent:** Monday, 13 January 2020 10:57 AM  
**To:** Paul Best <Paul.Best@rfs.nsw.gov.au>; Leanne Bell <Leanne.Bell@rfs.nsw.gov.au>  
**Subject:** FW: Bushfire Management Plan- Rix's Creek Mine

---

**From:** Chris Knight <[cknight@bloomcoll.com.au](mailto:cknight@bloomcoll.com.au)>  
**Sent:** Monday, 13 January 2020 10:35 AM  
**To:** Hunter Valley Team <[HunterValleyTeam@rfs.nsw.gov.au](mailto:HunterValleyTeam@rfs.nsw.gov.au)>  
**Subject:** Bushfire Management Plan- Rix's Creek Mine

Hi Paul,  
I hope the New Year finds you well.

Thank you and your team for all of your fantastic work saving the many lives and properties over the last few months. I realise that you will have been far too busy to look at the Rix's Creek Bushfire Management Plan.

This email is just to check in so the Plan does not fall off my list. I look forward to hearing from you whenever you get a chance.

Thank you and your teams again for all your efforts with the recent bushfires.

Best Regards



**Chris Knight**

Environment Manager

E: [cknight@bloomcoll.com.au](mailto:cknight@bloomcoll.com.au) | T: 02 6578 8824 | M: 0403 058 777

W: [www.bloomcoll.com.au](http://www.bloomcoll.com.au)

PO Box 4, East Maitland, NSW 2323

North: Bridgman Road, South: Rixs Creek Lane, Singleton, NSW 2330 Australia

**WE CARE. WE DELIVER.**

Please note: If you have received this e-mail in error, please notify the sender immediately by reply e-mail and delete all copies of this transmission together with any attachments as the information contained and any attached files may be confidential and/or subject of legal professional privilege.

---

**From:** Chris Knight

**Sent:** Wednesday, 30 October 2019 12:21 PM

**To:** 'huntervalley.team@rfs.nsw.gov.au' <[huntervalley.team@rfs.nsw.gov.au](mailto:huntervalley.team@rfs.nsw.gov.au)>

**Cc:** Chris Quinn <[cquinn@bloomcoll.com.au](mailto:cquinn@bloomcoll.com.au)>; Geoff Moore <[gmoore@bloomcoll.com.au](mailto:gmoore@bloomcoll.com.au)>; Hannah Lumsden <[hlumsden@bloomcoll.com.au](mailto:hlumsden@bloomcoll.com.au)>

**Subject:** Bushfire Management Plan- Rix's Creek Mine

**Attn: Paul Best, Team Manager, Hunter Valley Team.**

Dear Paul,

The Rix's Creek South Continuation Project was recently approved for a further 21 years. As part of this approval Rix's Creek Mine are required to prepare a Bushfire Management Plan for the development in consultation with RFS. In accordance with this condition, please find attached the Rix's Creek Mine Bushfire Management Plan for your review and comment.

If you have any questions or require any further information please do not hesitate to contact this office.

Best Regards,



**Chris Knight**

Environment Manager

E: [cknight@bloomcoll.com.au](mailto:cknight@bloomcoll.com.au) | T: 02 6578 8824 | M: 0403 058 777

W: [www.bloomcoll.com.au](http://www.bloomcoll.com.au)

PO Box 4, East Maitland, NSW 2323

North: Bridgman Road, South: Rixs Creek Lane, Singleton, NSW 2330 Australia

**WE CARE. WE DELIVER.**

Please note: If you have received this e-mail in error, please notify the sender immediately by reply e-mail and delete all copies of this transmission together with any attachments as the information contained and any attached files may be confidential and/or subject of legal professional privilege.

## Chris Knight

---

**From:** Chris Knight  
**Sent:** Friday, 24 January 2020 1:33 PM  
**To:** 'Leanne Bell'  
**Subject:** RE: Bushfire Management Plan- Rix's Creek Mine  
**Attachments:** SSD6300\_Bushfire Management Plan\_V1.1\_FINAL\_to\_RFS.pdf

Hi Leanne,

Thank you for your recent email containing further information on the development of Bushfire Management Plans for the Hunter Valley. Please find attached updated bushfire management plan for Rix's Creek mine incorporating the information provided.

Sections updated from the draft version are noted in yellow highlight.

The updates include the following

- correction to the bushfire danger period for the Singleton' and Muswellbrook LGA's
- inclusion of information on the bushfire committee,
- inclusion of information on the RFS district and
- inclusion of information on the fire weather area.

There is no rush with any response to this plan. A copy will be placed on our website. Whenever you get a chance we would appreciate any feedback.

Best Regards



**Chris Knight**

Environment Manager

E: [cknight@bloomcoll.com.au](mailto:cknight@bloomcoll.com.au) | T: 02 6578 8824 | M: 0403 058 777

W: [www.bloomcoll.com.au](http://www.bloomcoll.com.au)

PO Box 4, East Maitland, NSW 2323

**WE CARE. WE DELIVER.**

North: Bridgman Road, South: Rixs Creek Lane, Singleton, NSW 2330 Australia

Please note: If you have received this e-mail in error, please notify the sender immediately by reply e-mail and delete all copies of this transmission together with any attachments as the information contained and any attached files may be confidential and/or subject of legal professional privilege.

---

**From:** Leanne Bell [mailto:[Leanne.Bell@rfs.nsw.gov.au](mailto:Leanne.Bell@rfs.nsw.gov.au)]  
**Sent:** Monday, 13 January 2020 11:44 AM  
**To:** Chris Knight <[cknight@bloomcoll.com.au](mailto:cknight@bloomcoll.com.au)>  
**Cc:** Paul Best <[Paul.Best@rfs.nsw.gov.au](mailto:Paul.Best@rfs.nsw.gov.au)>  
**Subject:** FW: Bushfire Management Plan- Rix's Creek Mine

Hi Chris,

Thanks for a copy of your plan and map for your Bush Fire Management Plan. I have been on deployment since early October and have not seen my desk for some time. I'm not going to have the time to provide feedback on your plan in the near future. It would be beneficial to both organisations that in future, Bush Fire Management Plans are submitted prior to the 1<sup>st</sup> September, the beginning of Fire Season.

Attached is a fact sheet for the Mining Industry on Bush Fire Management Plans, please review and ensure that the correct details are included in your plan. The most common error in the plans are:

- Bush Fire Danger Period – for the Hunter Valley area (Singleton & Muswellbrook LGA's) this is 1<sup>st</sup> September to 31 March
- Bush Fire Management Committee name – Hunter Valley Bush Fire Management Committee
- Fire weather area – Greater Hunter
- NSW RFS district – Hunter Valley District

- Contact Phone number business hours – 6575 1200

If you make changes to your plan as a result of this fact sheet, please record them in the consultation section of your plan and then re-send to me for our records.

Thanks and regards  
Leanne



**Leanne Bell** | Operational Officer | Hunter Valley

**NSW RURAL FIRE SERVICE**

2161 Putty Road Bulga NSW 2330 | PO Box 3111 Singleton NSW 2330

**P** 02 6575 1200 **F** 02 6575 1299 **M** 0428 343 402 **E** [Leanne.Bell@rfs.nsw.gov.au](mailto:Leanne.Bell@rfs.nsw.gov.au)

[www.rfs.nsw.gov.au](http://www.rfs.nsw.gov.au) | [www.facebook.com/nswrfs](https://www.facebook.com/nswrfs) | [www.twitter.com/nswrfs](https://www.twitter.com/nswrfs)

**PREPARE. ACT. SURVIVE.**

---

**From:** Hunter Valley Team <[HunterValleyTeam@rfs.nsw.gov.au](mailto:HunterValleyTeam@rfs.nsw.gov.au)>

**Sent:** Monday, 13 January 2020 10:57 AM

**To:** Paul Best <[Paul.Best@rfs.nsw.gov.au](mailto:Paul.Best@rfs.nsw.gov.au)>; Leanne Bell <[Leanne.Bell@rfs.nsw.gov.au](mailto:Leanne.Bell@rfs.nsw.gov.au)>

**Subject:** FW: Bushfire Management Plan- Rix's Creek Mine

---

**From:** Chris Knight <[cknight@bloomcoll.com.au](mailto:cknight@bloomcoll.com.au)>

**Sent:** Monday, 13 January 2020 10:35 AM

**To:** Hunter Valley Team <[HunterValleyTeam@rfs.nsw.gov.au](mailto:HunterValleyTeam@rfs.nsw.gov.au)>

**Subject:** Bushfire Management Plan- Rix's Creek Mine

Hi Paul,

I hope the New Year finds you well.

Thank you and your team for all of your fantastic work saving the many lives and properties over the last few months. I realise that you will have been far too busy to look at the Rix's Creek Bushfire Management Plan.

This email is just to check in so the Plan does not fall off my list. I look forward to hearing from you whenever you get a chance.

Thank you and your teams again for all your efforts with the recent bushfires.

Best Regards



**Chris Knight**

Environment Manager

**E:** [cknight@bloomcoll.com.au](mailto:cknight@bloomcoll.com.au) | **T:** 02 6578 8824 | **M:** 0403 058 777

**W:** [www.bloomcoll.com.au](http://www.bloomcoll.com.au)

PO Box 4, East Maitland, NSW 2323

North: Bridgman Road, South: Rixs Creek Lane, Singleton, NSW 2330 Australia

**WE CARE. WE DELIVER.**

Please note: If you have received this e-mail in error, please notify the sender immediately by reply e-mail and delete all copies of this transmission together with any attachments as the information contained and any attached files may be confidential and/or subject of legal professional privilege.

---

**From:** Chris Knight

**Sent:** Wednesday, 30 October 2019 12:21 PM

To: 'huntervalley.team@rfs.nsw.gov.au' <[huntervalley.team@rfs.nsw.gov.au](mailto:huntervalley.team@rfs.nsw.gov.au)>

Cc: Chris Quinn <[cquinn@bloomcoll.com.au](mailto:cquinn@bloomcoll.com.au)>; Geoff Moore <[gmoore@bloomcoll.com.au](mailto:gmoore@bloomcoll.com.au)>; Hannah Lumsden <[hlumsden@bloomcoll.com.au](mailto:hlumsden@bloomcoll.com.au)>

**Subject:** Bushfire Management Plan- Rix's Creek Mine

**Attn: Paul Best, Team Manager, Hunter Valley Team.**

Dear Paul,

The Rix's Creek South Continuation Project was recently approved for a further 21 years. As part of this approval Rix's Creek Mine are required to prepare a Bushfire Management Plan for the development in consultation with RFS. In accordance with this condition, please find attached the Rix's Creek Mine Bushfire Management Plan for your review and comment.

If you have any questions or require any further information please do not hesitate to contact this office.

Best Regards,



**Chris Knight**

Environment Manager

E: [cknight@bloomcoll.com.au](mailto:cknight@bloomcoll.com.au) | T: 02 6578 8824 | M: 0403 058 777

W: [www.bloomcoll.com.au](http://www.bloomcoll.com.au)

PO Box 4, East Maitland, NSW 2323

**WE CARE. WE DELIVER.**

North: Bridgman Road, South: Rixs Creek Lane, Singleton, NSW 2330 Australia

Please note: If you have received this e-mail in error, please notify the sender immediately by reply e-mail and delete all copies of this transmission together with any attachments as the information contained and any attached files may be confidential and/or subject of legal professional privilege.

## Chris Quinn

---

**From:** Chris Quinn  
**Sent:** Wednesday, 25 March 2026 1:30 PM  
**To:** 'hunterminevalley.team@rfs.nsw.gov.au'; 'hunter.valley@rfs.nsw.gov.au'  
**Cc:** Julius Harris-Payne; Brendon Clements  
**Subject:** Rix's Creek Mine Bush Fire Management Plan consultation  
**Attachments:** SSD6300\_Bushfire Management Plan\_V1.3\_FINAL\_to\_RFS.pdf

Hello Tim Cassar,

Rix's Creek Mine has a condition of our Development Approval (SSD6300) to consult with the Rural Fire Service when developing our Bushfire Management Plan.

In accordance with this condition, please find attached the Rix's Creek Mine Bushfire Management Plan for your review and comment.

If you have any questions or need more information, please contact me.

Regards,



**Chris Quinn**

Environmental Superintendent

E: [cquinn@bloomcoll.com.au](mailto:cquinn@bloomcoll.com.au) | T: 02 65 788888 | M: 0427 169 302

W: [www.bloomcoll.com.au](http://www.bloomcoll.com.au)

PO Box 4, East Maitland, NSW 2323

**WE CARE. WE DELIVER.**

North: Bridgman Road, South: Rixs Creek Lane, Singleton, NSW 2330 Australia

Please note: If you have received this e-mail in error, please notify the sender immediately by reply e-mail and delete all copies of this transmission together with any attachments as the information contained and any attached files may be confidential and/or subject of legal professional privilege.